

INTRODUCTION TO HVAC

CHILLED WATER SYSTEM

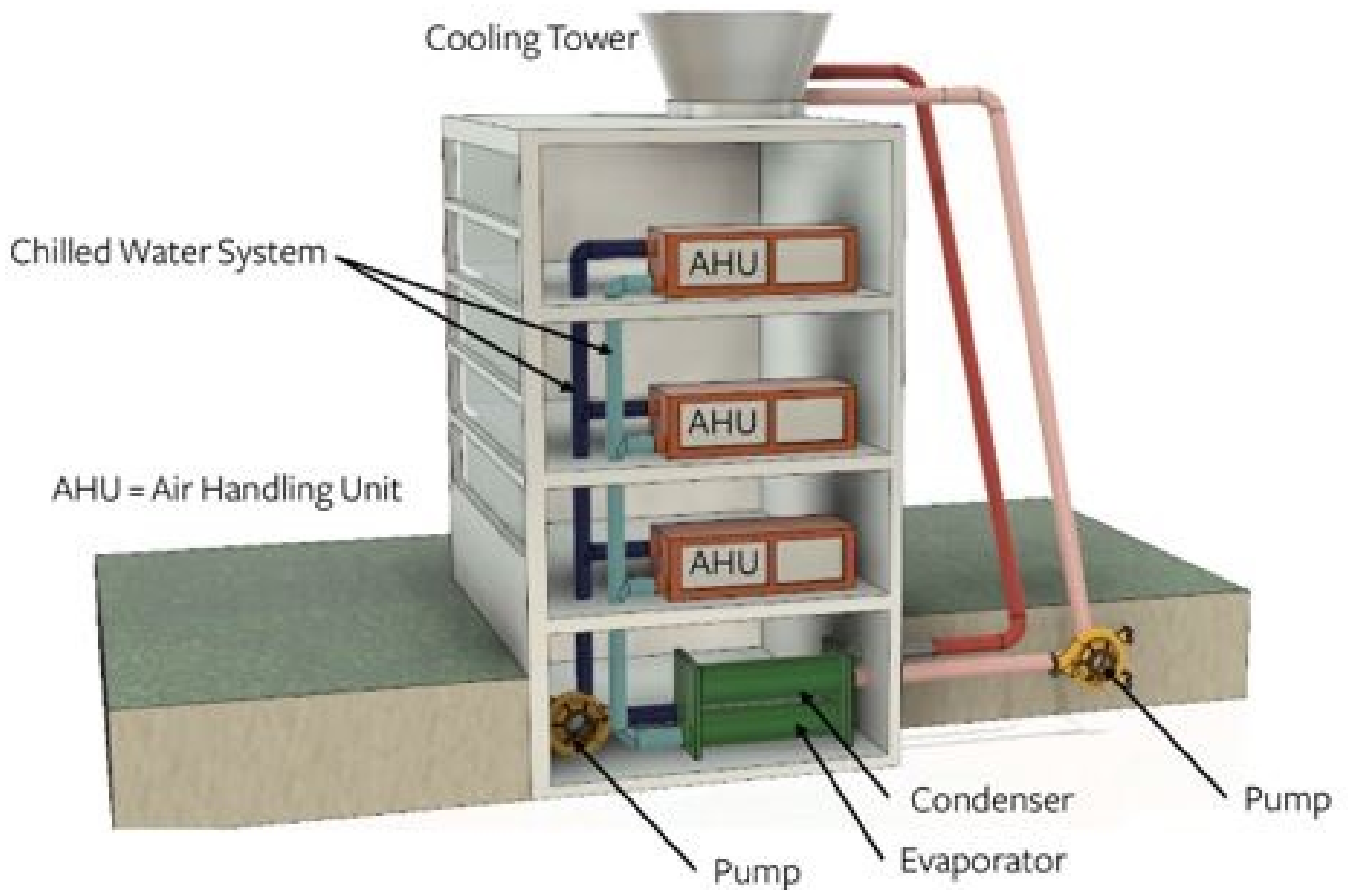

EXPLAINED

ASSEMBLED BY



www.hvacsimplicated.in

TABLE OF CONTENTS

1. CHILLED WATER SYSTEMS.....	3
1.1 Introduction to Chilled Water System.....	3
1.2 HVAC Systems.....	4
1.2 Psychometrics.....	8
2. ESTIMATION OF HEAT LOADS.....	1
2.1 Principles of Heat Transfer.....	1
2.2 Cooling Loads Classified By Kinds Of Heat.....	3
2.3 Design Conditions of the Project.....	10
2.4 Calculation of Total Heat Load.....	11
3. CENTRALIZED AIR-CONDITIONING SYSTEMS.....	12
3.1 General Schematic of Air-Conditioning.....	12
3.2 Air-Conditioning Equipment.....	13
3.2.1 Chillers.....	13
3.2.2 Fan Coil Units.....	22
3.2.3 Pumps.....	22
3.2.4 Diffusers.....	24
4. CHILLED WATER AIR-CONDITIONING SYSTEM.....	31
4.1 Chilled-Water Air-Conditioning System.....	31
4.2 Conceptual view of a chilled-water air-conditioning system.....	32
4.3 Waste Heat Rejection - Refrigeration Condensers.....	33
4.4 Piping System.....	36
Other Elements.....	39
5. FINAL LAYOUTS.....	42
5.1 Piping Layouts.....	42
6. CONCLUSION.....	43
7. BIBLIOGRAPHY.....	44

1. CHILLED WATER SYSTEMS

1.1 Introduction to Chilled Water System

Chilled Water System, also called as Hydronics is one of the major requirement in a Centralized Air-Conditioning System. Chilled water is a commodity often used to cool a building's air and equipment, especially in situations where many individual rooms must be controlled separately, such as a hotel. The chilled water can be supplied by a vendor, such as a public utility or created at the location of the building that will use it, which has been the norm.

Chilled water cooling is very different from typical residential air conditioning where a refrigerant is pumped through an air handler to cool the air. Regardless of who provides it, the chilled water (between 4° and 7°C) is pumped through an air handler, which captures the heat from the air, then disperses the air throughout the area to be cooled.

The condenser water absorbs heat from the refrigerant in the condenser barrel of the water chiller, and is then sent via return lines to a cooling tower, which is a heat exchange device used to transfer waste heat to the atmosphere. The extent to which the cooling tower decreases the temperature depends upon the outside temperature, the relative humidity and the atmospheric pressure. The water in the chilled water circuit will be lowered to the Wet-bulb temperature or dry-bulb temperature before proceeding to the water chiller, where it is cooled to between 4° and 7°C and pumped to the air handler, where the cycle is repeated. The equipment required includes chillers, cooling towers, pumps and electrical control equipment. The initial capital outlay for these is substantial and maintenance costs can fluctuate. Adequate space must be included in building design for the physical plant and access to equipment.

The chilled water, which absorbed heat from the air, is sent via return lines back to the utility facility, where the process described in the previous section occurs. Utility generated chilled water eliminates the need for chillers and cooling towers at the property, reduces capital outlays and eliminates ongoing maintenance costs. The physical space saved can also become rentable, increasing revenue.

Utility supplied chilled water has been used successfully since the 1960s in many cities, and technological advances in the equipment, controls and trenchless installation have increased efficiency and lowered costs.

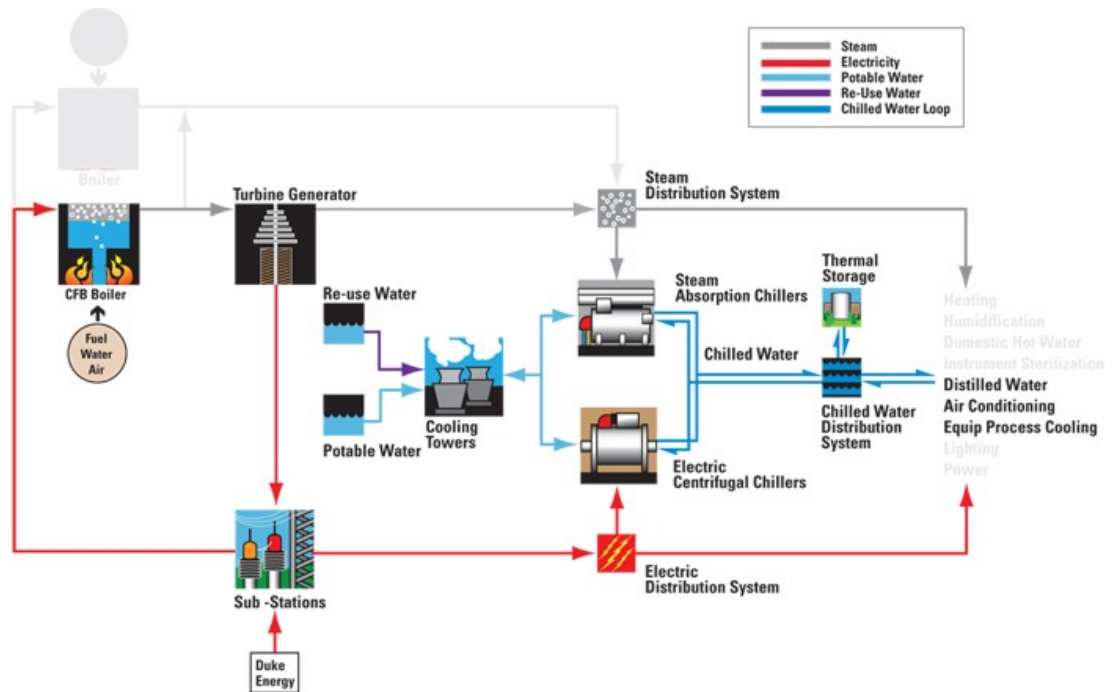

Figure 1.1: Water Systems

The advantage of utility-supplied chilled water is based on economy of scale. A utility can operate one large system more economically than a customer can operate the individual system in one building. The utility's system also has back-up capacity to protect against sudden outages. The cost of such "insurance" is also markedly lower than what it would be for an individual structure.

The use of utility supplied chilled water is most cost effective when it is designed into the building's infrastructure or when chiller/cooling tower equipment must be replaced. Commercial customers often lower their air conditioning costs from 10-20% by purchasing chilled water.

1.2 HVAC Systems

HVAC is an acronym that stands for "Heating, Ventilation and Air-Conditioning." Often installed into a single system, these three functions of the HVAC system are closely interrelated to provide thermal comfort and to maintain good indoor air quality. HVAC is sometimes referred to as climate control because it provides heating,

cooling, humidity control, filtration, fresh air, building pressure control, and comfort control.

HVAC is one of the largest consumers of energy in the hospitality industry, constituting approximately 30 percent or more of total costs. HVAC systems that operate properly are essential in lodging facilities and contribute to employee productivity and guest satisfaction. Because HVAC systems account for so much electric energy use, almost every facility has the potential to achieve significant savings by improving its control of HVAC operations and improving the efficiency of the system it uses through proper design, installation and scheduled maintenance. The following sections outline some important components of the HVAC system as well as offer suggestions to improve your facility's efficiency.

HVAC includes a variety of active mechanical/electrical systems employed to provide thermal control in buildings. Control of the thermal environment is a key objective for virtually all occupied buildings. For thousands of years such control may have simply been an attempt to ensure survival during cold winters. In the modern architectural context, thermal control expectations go far beyond survival and involve fairly complex thermal comfort and air quality concerns that will influence occupant health, satisfaction and productivity.

A heating system ("H" in HVAC) is designed to add thermal energy to a space or building in order to maintain some selected air temperature that would otherwise not be achieved due to heat flows (heat loss) to the exterior environment. A ventilating system ("V") is intended to introduce air to or remove air from a space -- to move air without changing its temperature. Ventilating systems may be used to improve indoor air quality or to improve thermal comfort. A cooling system ("C" is not explicitly included in the HVAC acronym) is designed to remove thermal energy from a space or building to maintain some selected air temperature that would otherwise not be achieved due to heat flows (heat gain) from interior heat sources and the exterior environment. Cooling systems are normally considered as part of the "AC" in HVAC; AC stands for air-conditioning.

An air-conditioning system, by ASHRAE (American Society of Heating, Refrigerating and Air-Conditioning Engineers) definition, is a system that must accomplish four objectives simultaneously. These objectives are to: control air

temperature; control air humidity; control air circulation; and control air quality. Although the word “control” is often loosely construed, encompassing anything from pin-point control for central computer facilities to ballpark control for residences, the requirement that an air-conditioning system simultaneously modify four properties of air demands reasonably sophisticated systems. This module will focus on air-conditioning systems, as owner and occupant expectations for many common building types tend to require the use of this broad family of systems. Heating systems (such as portable electric heaters or fireplaces), ventilating systems (such as whole-house fans or make-up air units), and sensible-cooling-only systems are also used in buildings and will be discussed in this module. The emphasis, however, will be on multi-function air-conditioning systems. HVAC systems are of great importance to architectural design efforts for four main reasons. First, these systems often require substantial floor space and/or building volume for equipment and distribution elements that must be accommodated during the design process.

The basic purpose of an HVAC system is to provide interior thermal conditions that a majority of occupants will find acceptable. Occasionally this may simply require that air be moved at an adequate velocity to enhance convective cooling and evaporation from the skin. Much more commonly, however, providing for occupant comfort will require that an HVAC system add or remove heat to or from building spaces. In addition, it is normally necessary for moisture to be removed from spaces during the summer; sometimes moisture will need to be added during the winter. The heat and moisture control functions of HVAC systems provide the foundation for key system components. The additional functions of air circulation and air quality control establish further component requirements. In specific building situations, supplemental functions, such as controlling smoke from fires or providing background noise for acoustic privacy, may be imposed on an HVAC system -- along with a potential need for additional components. Before proceeding further, it is necessary to explain a number of the terms and concepts that help to define the character of an HVAC system.

Each building has a characteristic exterior air temperature, known as the balance point temperature, at which the building in use would be able to support thermal comfort without the need for a heating or cooling system. At the balance point temperature, which is strongly influenced by internal loads and envelope design, building heat

gains and losses are in equilibrium so that an appropriate interior temperature will be maintained naturally and without further intervention. When the outside air temperature falls below the balance point temperature, heat losses through the building envelope will increase – and interior air temperature will drop unless heat is added to the building to compensate. A system that provides such additional heat is called a space (or building) heating system. When the outside air temperature exceeds the balance point temperature, heat gain through the building envelope will upset thermal equilibrium and cause the interior air temperature to rise. A system that removes such excess heat is called a cooling system. Those times of the year when heat gain is of concern are collectively termed the overheated period; the under-heated period includes those times when heat loss is of concern. Space heat may be added or removed by an electro-mechanical system, which is termed an active systems approach. An active system has the following general characteristics: it normally utilizes purchased energy for its operation, it requires special-purpose components that serve no other major building function, and it is generally relatively independent of the underlying architectural elements of the building. Alternatively, space heat may be added or removed by a system designed to make use of naturally occurring environmental forces. Such a system is termed a passive system. A passive system has the following general characteristics: it utilizes renewable site resources for energy inputs, it usually involves components that are integral parts of other building systems, and it is usually so tightly interwoven with the basic architectural fabric of a building that removal would be difficult. Control of an HVAC system is critical to its successful operation. The issue of system control leads to the concept of HVAC zoning. During the design process, a zone is defined as a region of a building that requires separate control if comfort is to be provided for occupants. For example, it may not be possible to successfully condition a below ground office area and a glass enclosed atrium from a single control point. The dynamics of the thermal loads in the two spaces are simply not compatible. To provide comfort, each space must be provided with its own control -- the climate control system must be designed to accommodate separate thermal zones. In an existing building, a zone is easily identified as an area operated from a single control point (typically a thermostat in an active system). Zoning is very much an architectural responsibility as it requires an understanding of building function and schedules. Typically the two key elements to consider when establishing thermal zones are differential solar radiation exposures (a

north facade versus an east facade) and differential operating schedules and loading requirements (an occasionally used assembly hall versus a normally occupied office suite). Thermal zones must be established very early in the HVAC system design process.

HVAC system components may be grouped into three functional categories: source components, distribution components, and delivery components. Source components provide or remove heat or moisture. Distribution components convey a heating or cooling medium from a source location to portions of a building that require conditioning. Delivery components serve as an interface between the distribution system and occupied spaces. Compact systems that serve only one space or zone of a building (local systems) often incorporate all three functions in a single piece of equipment. Systems that are intended to condition multiple spaces in a building (central systems) usually have distinctly different equipment elements for each function.

1.3 Psychometrics

Psychometrics is the science of studying the thermodynamic properties of moist air. It is widely used to illustrate and analyze the change in properties and the thermal characteristics of the air-conditioning process and cycles.

Psychometric Charts

A *psychometric chart's* a graphical presentation of the thermodynamic properties of moist air and various air-conditioning processes and air-conditioning cycles. A psychometric chart also helps in calculating and analyzing the work and energy transfer of various air-conditioning processes and cycles.

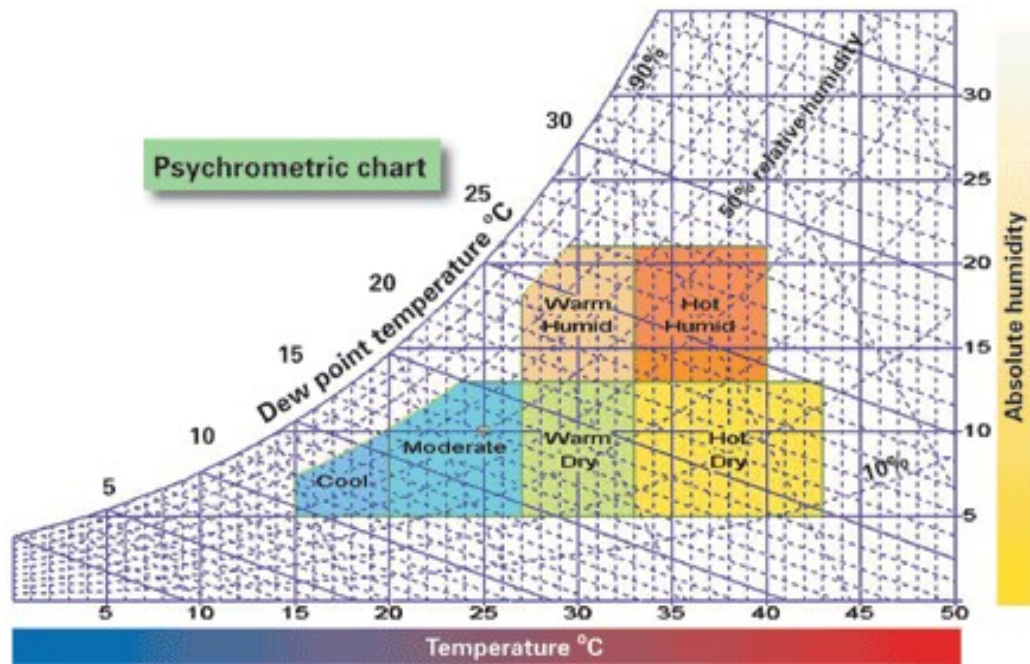

Figure 1.2: Water Cooled Chillers

Relative Humidity: Is defined as the amount of water vapour present in a sample of air to saturated air expressed in percentage.

Dry Bulb Temperature: It is the temperature measured by an ordinary thermometer; it is the indication of the sensible heat.

Wet Bulb Temperature: It is the temperature measured by an ordinary thermometer with the bulb covered by a wetted cloth. It is the indication of latent heat.

Dew Point Temperature: It is the threshold temperature below which the moisture starts condensing into liquid.

Specific Humidity or Moisture Content: The weight of water vapor in grains or pounds of moisture per pound of dry air.

Enthalpy: It is a thermal property indicating the quantity of heat in the air above an arbitrary datum in BTU per pound of dry air. The datum for dry air is 0°F and for moisture content 32°F water.

Sensible Heat Factor: The ratio of sensible to total heat.

2. ESTIMATION OF HEAT LOADS

2.1 Principles of Heat Transfer

The three basic principles of Heat Transfer are as given,

1) **Heat energy cannot be destroyed; it can only be transferred to another substance.**

To produce cooling, heat must be removed from a substance by transferring the heat to another substance. This is commonly referred to as the principle of "conservation of energy." Ice cubes are typically placed in a beverage to cool it before being served. As heat is transferred from the beverage to the ice, the temperature of the beverage is lowered. The heat removed from the beverage is not destroyed, but instead is absorbed by the ice, melting the ice from a solid to a liquid.



Fig 2.1 Heat Transfer

2) **Heat energy naturally flows from a higher-temperature substance to a lower-temperature substance, in other words, from hot to cold.**

Heat cannot naturally flow from a cold substance to a hot substance. Consider the example of the beverage and the ice cubes. Because the temperature of the beverage is higher than the temperature of the ice cubes, heat will always flow from the beverage to the ice cubes.

3) **Heat energy is transferred from one substance to another by one of three basic processes: conduction, convection, or radiation.**

Methods of Heat Transfer

The device shown is a baseboard convactor that is commonly used for heating a space. It can be used to demonstrate all three processes of transferring heat. Hot water flows through a tube inside the convactor, warming the inside surface of the tube. Heat is transferred, by conduction, through the tube wall to the slightly cooler fins that are attached to the outside surface of the tube. Conduction is the process of transferring heat through a solid. The heat is then transferred to the cool air that comes into contact with the fins. As the air is warmed and becomes less dense, it rises, carrying the heat away from the fins and out of the convactor.

This air movement is known as convection current. Convection is the process of transferring heat as the result of the movement of a fluid. Convection often occurs as the result of the natural movement of air caused by temperature (density) differences.

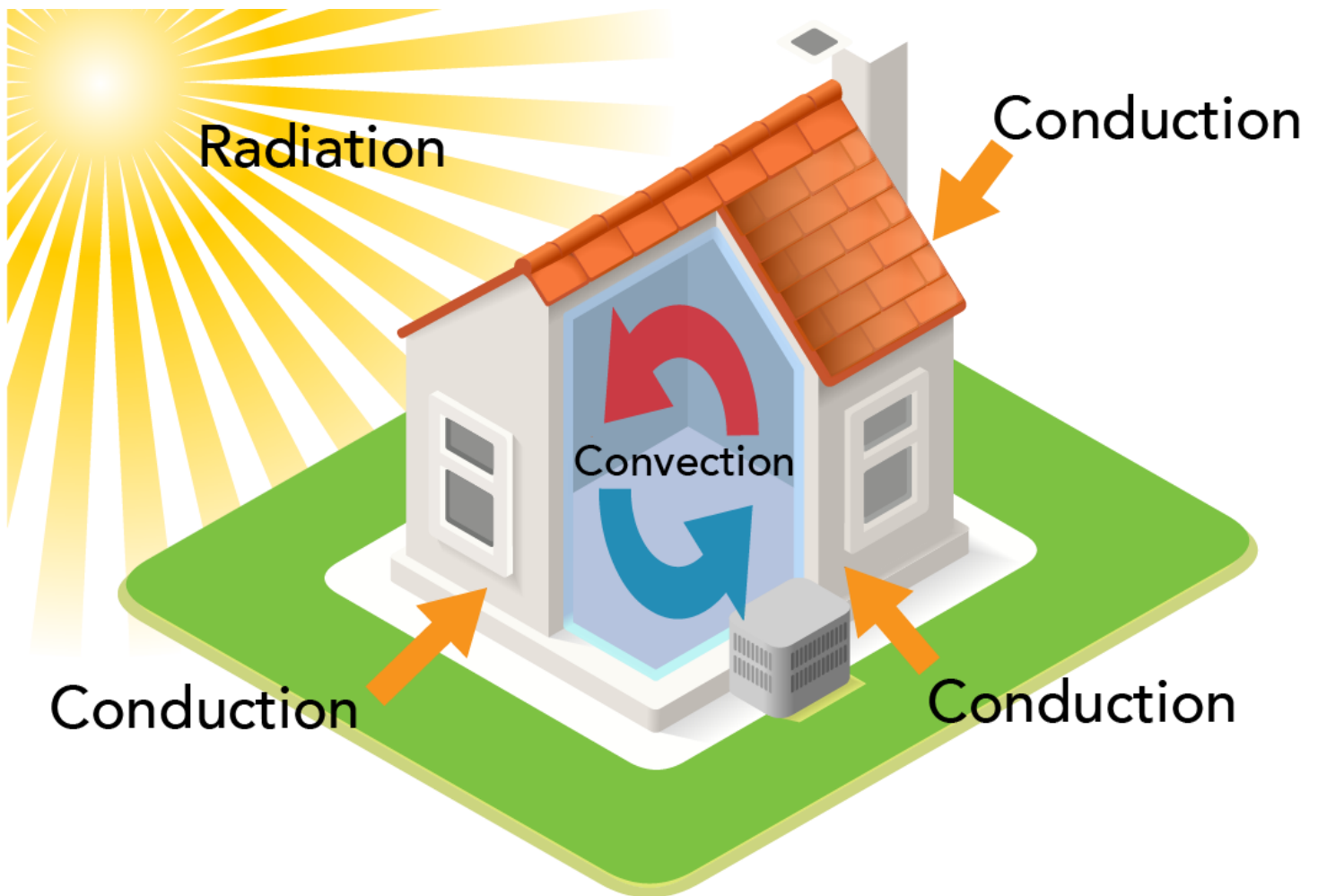

Fig 2.2 Methods of Heat Transfer

Additionally, heat is radiated from the warm cabinet of the convector and warms cooler objects within the space. Radiation is the process of transferring heat by means of electromagnetic waves, emitted due to the temperature difference between two objects. An interesting thing about radiated heat is that it does not heat the air between the source and the object it contacts; it only heats the object itself.

Measuring Heat Quantity

In the I-P system of units, the unit for measuring the quantity of heat is the British thermal unit (Btu). The Btu is defined as the quantity of heat energy required to raise the temperature of 1 lb of water 1°F. Similarly, in the Systeme International (SI) system, heat quantity can be

expressed using the unit kilo Joule (kJ). A kcal is defined as the amount of heat energy required to raise the temperature of 1 kg of water 1°C. One kcal is equal to 4.19 kJ.

In heating and cooling applications, however, emphasis is placed on the rate of heat transfer, that is, the quantity of heat that flows from one substance to another within a given period of time. This rate of heat flow is commonly expressed in terms of Btu/hr—the quantity of heat, in Btu, that flows from one substance to another during a period of 1 hour. Similarly, in the SI metric system of units, the rate of heat flow is expressed in terms of kilowatts (kW). One kW is equivalent to 1 kJ/sec. One kilowatts describes the quantity of heat, in kJ, that flows from one substance to another during a period of 1 second. Finally, the rate of heat flow may often be expressed in terms of watts (W). One kW is equivalent to 1000 W.

2.2 Cooling Loads Classified By Kinds Of Heat

There are two components of air conditioning load 1) Sensible Load (Heat gain) 2) Latent Load (Water Vapour Gain)

Sensible Loads

Sensible heat gain is the direct addition of heat to a space, which results in increase of space temperature.

- 1) Solar heat gain through building envelope (Exterior walls, glazing, skylights, roofs, floors over crawl space)
- 2) Partitions
- 3) Ventilation air and air infiltration through cracks in the building, doors and windows.
- 4) People in the building
- 5) Equipment and appliances in the summer.
- 6) Lights

Latent Loads

A latent heat gain is the heat contained in water vapor. It is the heat that must be removed to condense the moisture out of the air.

- 1) People breathing
- 2) Cooking Equipment
- 3) Appliances
- 4) Ventilation air and air infiltration

Detailed Description Of Cooling Loads

The cooling load is more complicated than the heating load to calculate. In the cooling load the walls and windows are to be calculated for each side of the building. The heat transfer through the roof is to be determined. The slab is not to be calculated due to there is no heat gain from the ground. The internal gains (people, equipment, lights) are to be considered. The weather data is based on ASHRAE design data.

Wall: The material for the walls is the same so therefore the Rf is the same for the cooling as it is in the heating. The area of the wall will also be the same. The cooling load temperature difference (CLTD) is to be determined. The CLTD takes into account the transient effects of the conductive heat gains and radioactive heat gains that do not enter the indoor air directly. The CLTD is determined by the type of wall and which direction the wall is facing. The CLTD is different for each direction. The heat flow through the walls is calculated by the following equation:

$$Q = U * A (CLTD)$$

Where,

A is the area of the wall

U is the Coefficient of Heat Transfer

CLTD is the cooling load temperature difference for the wall

Windows: The windows are calculated in two parts, for conduction and the heat gain due to solar radiation transmitted through or absorbed by glass.

The conduction heat flow for the windows is calculated closely to the same manner as in the heating load. The U value is found in the same manner as for the heating load calculations, but reflects the summer months. The CLTD is also determined for the windows. The heat flow through the windows due to conduction is calculated by the following equation:

$$Q = U * A (CLTD)$$

Where,

U is inverse of the resistance of the window

A is the area of the windows

CLTD is the cooling load temperature difference for the window.

The solar heat gain through the windows is to be calculated separately for the different directions the windows are facing. A shading coefficient (SC) is determined by the type of glazing and by the thickness of each glazing. The north latitude, the direction facing, and the month with the highest average temperature determine the solar heat gain factor. The type of furnishings, the thickness of the slab, the room air circulation, the solar time, and the facing direction determine the cooling load factor (CLF). The heat flow by solar heat gain is calculated by the following equation:

$$Q = A * SC * SHGF * CLF$$

Where,

A is the area of the windows

SC is the shading coefficient

SHGF is solar heat gain factor

CLF is the cooling load factor

Roof

The material of the roof is the same therefore the R_c is the same as calculated in the heating calculations. The area is also the same. The materials of the roof and the solar time are used to determine the CLTD for the roof. The heat flow through the roof is calculated by the following equation:

$$Q = U * A * CLTD$$

Where,

A is the area of the roof

R_c is the resistance of the roof components

CLTD is the cooling load temperature difference for the roof

Lights

The heat gain for the lights is dependent upon several factors. The CLF for the lights is determined by the type of furnishings inside the building, the slab construction thickness, the air circulation rate, and the amount of time the lights are turned on. The total wattage from all of the lights also needs to be known. A special ballast allowance factor is taken into account. Variations of the actual wattage are taken into account by the diversity factor. The heat gain from the light is calculated by the following equation:

$$Q = Watts * F_u * F_s * CLF$$

Where,

Watts is the total wattage from all of the lights

F_u is the diversity factor

F_s is the ballast special allowance factor

CLF is the cooling load factor for the lights

People: The heat gain by the occupants in the building is separated into sensible and latent. The number of people, the type of activity they are performing, and the CLF determines the sensible heat. The CLF is determined by the time the occupants come into the building and for how long they stay in the building. The sensible heat gain by the occupants is calculated by the following equation:

$$Q = N * q_M * CLF$$

Where,

N is the number of people

Q (sensitive) is the sensible heat gain per person

CLF is the cooling load factor for the occupants

The number of people and the type of activity they are performing determines the latent heat gain. The latent gain is assumed to immediately translate onto the cooling load and for this reason there is no CLF. The latent heat gain by the occupants is calculated by the following equation:

$$Q = N * Q_{lat}$$

Where,

N is the number of people,

Q(latent) is the latent heat gain per person

Equipment: The heat gain by the equipment is determined by the wattage and the CLF for the equipment. The CLF is found by the operational hours and the time the equipment is turned on. This must be found for each individual piece of equipment. The heat gain by each individual piece of equipment is calculated by the following equation:

$$O = Watts * CLF$$

Where,

Watts is the wattage of the equipment

CLF is the cooling load factor for the equipment

The total heat gain by the equipment is the sum of the heat gain by the individual pieces of equipment.

Infiltration

The infiltration is separated into sensible and latent heat gains. The sensible heat gain is calculated in the same manner as for the heating load. The air change method is used again to find the heat flow due to infiltration. The mass flow rate of the air is calculated by the following equation:

$$m = Vol * (ACH) * \rho \text{ (air)}$$

Where,

Vol is the volume of the building

ACH is the estimated air changes per hour

Once the mass flow rate of the air is found then the heat flow for the infiltration is calculated by the following equation:

$$Q = m * C_p (T_o - T_i)$$

Where,

m is the mass flow rate of the air

C_p is the specific heat of air

T_i is the inside temperature

T_o is the outside temperature

The latent heat gain is determined by the mass flow rate, the humidity ratio for the inside and outside air, and the enthalpy and the saturation point for the weather data. The latent heat gain for infiltration is calculated by the following equation:

$$Q = m(W_o - W_i)h_{fg}$$

Where,

m is the mass flow rate of the air

W_o is the humidity ratio of the outside air

W_i is the humidity ratio of the inside air

h_{fg} is the latent heat of vaporization of water

The total cooling load for the space is determined by the summation of all of the previously calculated heat gains. The cooling load for the cooling coils must now be determined. This is where the ventilation is incorporated in the cooling load.

Information Required (Inputs)

Before a cooling or heating load can be properly estimated a complete survey must be made of the physical data. The more exact the information that can be obtained about space characteristics, heat load sources, location of equipment and services, weather data, etc. the more accurate will be the load estimate.

Required Input - External Loads - Cooling

For calculation of the outdoor loads, the input information should include

1. Orientation and dimensions of building components
2. Construction materials for roof, walls, ceiling, interior partitions, floors and fenestration
3. Size and use of space to be conditioned
4. Surrounding conditions, outdoors and in adjoining spaces

Heating Load Sources

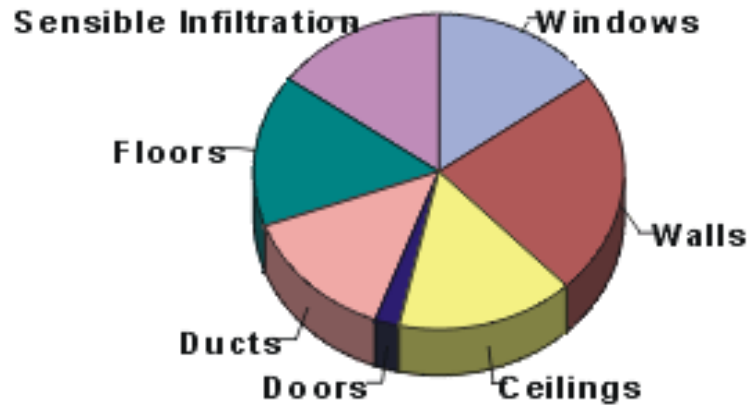

Figure 2.3 Sources of Heat

Film Coefficient

In addition to the resistance of the various components of a barrier, we have to consider one more resistance offered by a film of air (or fluid if the barrier is a fluid) which clings on to the barrier surfaces. This resistance is more when the air is still and is relatively less when there is wind velocity. The values of the same are given in the list of thermal resistances.

Storage Effect

Suppose “ T_o ” is the temperatures on both sides of the barrier. There will be no heat transmission through the barrier and the temperatures at all points within the barrier will also be the same. There is, therefore, no temperature gradient. The walls take about 2 hours approximately to start conducting the heat onto the inside space.

Procedure for Heat Load Estimation

1. Collect architect drawings for the building giving all details and dimensions of walls, floors, windows, etc. If such drawings are not available, survey the place and get the particulars.
2. For every application, there are certain things which the ultimate user has to specify. These are
 - a) Temperature & humidity conditions to be maintained inside the space and tolerance.

- b) Occupancy – i.e. maximum no. of people likely to occupy the space and the nature of their activity.
 - c) Lighting load and other internal source of heat generation.
 - d) Period of operation – e.g. 8 a.m. to 4 p.m. or 10 a.m. to 8 p.m. etc.
 - e) For industrial application you require the HP load in the conditioned space and diversity factor thereon.
 - f) Minimum ventilation required.
3. Outside Design Conditions
- a) For comfort air conditioning application, use the mean maximum DB temperature & the WB temperature which occurs simultaneously with the assumed DB.
 - b) For industrial applications where temperatures and humidities are to be maintained within very close tolerance through the year, take the maximum DB and the simultaneously occurring WB temperature.
4. For all applications make a second load estimate for monsoon conditions.
5. For applications where the conditioned spaces are spread over very vast floor areas, divide the entire area into convenient zones and make load estimates.
6. Occupancy - In certain applications a diversity factor may have to be used even in respect of occupancy. Examples are: Office areas where a separate conference room is also provided. The conference room may be designed for a large number of people. But you must realize that it is mostly the people in the office who go into conferences and hence any occupancy in the conference room brings about an equal reduction in the occupancy in other areas of the office.

2.3 Design Conditions of the Project

Outside Design Conditions :

Outside design condition is a combination of the temperature and the relative humidity of the external environment with respect to building structure.

Outside Conditions:

Temperature = 106°F (41°C)

$T_c = (5/9) * (T_f - 32)$

T_c = temperature in degrees Celsius

T_f = temperature in degrees Fahrenheit

Relative Humidity = 28%

Inside Design Conditions:

Inside design condition is a combination of the temperature and the relative humidity within the subjected building structure or the favorable conditions required within the building structure as per standards/clients.

Inside Conditions :

Temperature = 76°F (23°C)

Relative Humidity = 50%

2.4 Calculation of Total Heat Load

The Heat Load Calculation sheets for the project building as per each room/space are as given below. The values required herein for further calculations are the Tonnage and Litre/second flow of air of each room/space.

The Heat Load for the project is as below as per the floors.

3. CENTRALIZED AIR-CONDITIONING SYSTEMS

3.1 General Schematic of Air-Conditioning

The general schematic of air-conditioning in a building structure is shown below.

As shown in the schematic, the cycle consists of three basic equipment components and the transport system.

Equipments:

Pumps, Chillers, FCU/AHU, Diffusers

Transport System:

Piping, Ducting

As per the Chilled Water System as discussed in this report is further divided as per its location & application. As per location they are termed as Roof piping, Riser Piping & Floor Piping. As per application they are called as Supply pipe & Return pipe. Similarly ducting is also similarly classified on its application.

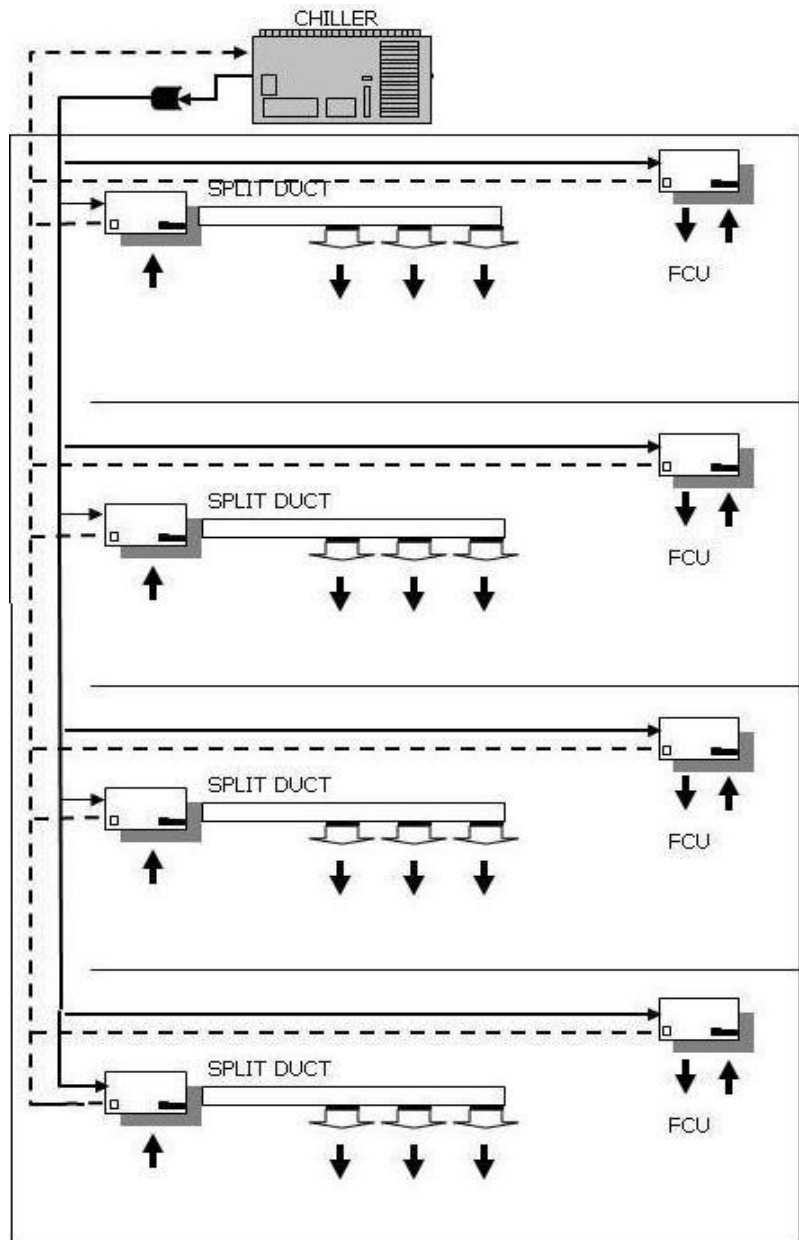

Figure 3.1: Central HVAC System

3.2 Air-Conditioning Equipment

The generally used machines for the air-conditioning of buildings such as HRB & LRB are as follows

3.2.1 Chillers

Heating, ventilation and air conditioning (HVAC) chillers are refrigeration systems that provide cooling for industrial and commercial applications. They use water, oils or other fluids as refrigerants. HVAC chillers include a compressor, condenser, thermal expansion valve, evaporator, reservoir, and stabilization assembly.

Compressing the refrigerant creates a high pressure, superheated gas that the condenser air-cools to a warm liquid. The thermal expansion valve (TXV) releases refrigerant into the evaporator, converting the warm liquid to a cool, dry gas. Often, a hot gas bypass is used to stabilize the cooling output by allowing the hot gas to warm up the



Figure 3.2: Chillers

evaporator. This causes a reduction in cooling efficiency, but stabilizes the chilled water temperatures. When water is pumped from the reservoir to the compressor, the chilling cycle begins again.

- HVAC chillers vary in terms of condenser cooling method, cooling specifications and process pump specifications.
- They are classified as Air-Cooled & Water-Cooled on basis of condenser cooling methods.
- They can be placed in series or parallel arrangement as required.

Air-cooled devices use a fan to force air over the condenser coils. By contrast, water-cooled devices fill the condenser coils with circulating water. Remote air or slit systems locate the

main part of the chiller in the application area and position the condenser remotely, usually outdoors. Cooling specifications for HVAC chillers include cooling capacity, fluid discharge temperature, and compressor motor horsepower. Typically, cooling capacity is measured in kilowatts or tons of refrigeration. Compressor motor horsepower is a nominal value. Process pump specifications include process flow, process pressure, and pump rating.

HVAC chillers include a local or remote control panel with temperature and pressure indicators. Some devices include microprocessor controls, emergency alarms, and an integral pump.

In industrial application, chilled water or other liquid from the chiller is pumped through process or laboratory equipment. Industrial chillers are used for controlled cooling of products, mechanisms and factory machinery in a wide range of industries. They are often used in the plastic industry in injection and blow molding, metal working cutting oils, welding equipment, die-casting and machine tooling, chemical processing, pharmaceutical formulation, food and beverage processing, paper and cement processing, vacuum systems, X-ray diffraction, power supplies and power generation stations, analytical equipment, semiconductors, compressed air and gas cooling. They are also used to cool high-heat specialized items such as MRI machines and lasers, and in hospitals, hotels and campuses.

Chillers for industrial applications can be centralized, where a single chiller serves multiple cooling needs, or decentralized where each application or machine has its own chiller. Each approach has its advantages. It is also possible to have a combination of both centralized and decentralized chillers, especially if the cooling requirements are the same for some applications or points of use, but not all.

Decentralized chillers are usually small in size and cooling capacity, usually from 0.2 tons to 10 tons. Centralized chillers generally have capacities ranging from ten tons to hundreds or thousands of tons.

Chilled water is used to cool and dehumidify air in mid- to large-size commercial, industrial, and institutional (CII) facilities. Water chillers can be water-cooled, air-cooled, or evaporatively cooled. Water-cooled chillers incorporate the use of cooling towers which improve the chillers' thermodynamic effectiveness as compared to air-cooled chillers. This is due to heat rejection at or near the air's wet-bulb temperature rather than the higher,

sometimes much higher, dry-bulb temperature. Evaporatively cooled chillers offer higher efficiencies than air-cooled chillers but lower than water-cooled chillers.

Water-cooled chillers are typically intended for indoor installation and operation, and are cooled by a separate condenser water loop and connected to outdoor cooling towers to expel heat to the atmosphere.

Air-cooled and evaporatively cooled chillers are intended for outdoor installation and operation. Air-cooled machines are directly cooled by ambient air being mechanically circulated directly through the machine's condenser coil to expel heat to the atmosphere. Evaporatively cooled machines are similar, except they implement a mist of water over the condenser coil to aid in condenser cooling, making the machine more efficient than a traditional air-cooled machine. No remote cooling tower is typically required with either of these types of packaged air-cooled or evaporatively cooled chillers.

Where available, cold water readily available in nearby water bodies might be used directly for cooling, place or supplement cooling towers. The Deep Lake Water Cooling System in Toronto, Canada, is an example. It uses cold lake water to cool the chillers, which in turn are used to cool city buildings via a district cooling system. The return water is used to warm the city's drinking water supply, which is desirable in this cold climate. Whenever a chiller's heat rejection can be used for a productive purpose, in addition to the cooling function, very high thermal effectiveness is possible.

Types of Chillers:

Depending on the type of cooling medium, the chillers are can be broadly classified as

- **Air Cooled Chillers:** Air-cooled chillers have many advantages over water-cooled equipment. While it is true that water-cooled equipment can offer better performance, by the time the condenser pumps and water cooling tower fans are included, the performance difference is not as big as you might think. In fact, at part load conditions, there might not be any difference



Figure 3.3: Air Cooled Chillers

at all. The biggest advantage of using air cooled chillers is that they do not require cooling towers or condenser water pumps. While this has traditionally made air-cooled chillers very popular with small to medium projects, it is becoming more common to see large plants (2,000 tons and larger) that use air-cooled chillers.

Another advantage of air-cooled chillers is they do not require a mechanical room for the chiller. This frees up considerable space for occupant use. Like all products, air-cooled chillers have special needs when applying them in a design. The following are several of the key items that should be addressed to achieve a proper operating chiller plant and a satisfied customer.

Air Circulation: Air-cooled chillers generate a lot of heat. Consider a 400-ton air-cooled screw chiller. That is equivalent to 4,800,000 Btu/hr. The heat of rejection from the compressors adds another 1,400,000 Btu/hr for a total of 6.2 Million Btu/hr of heat that must

be rejected to atmosphere. Air-cooled products use a sensible heat transfer process so the refrigerant condensing temperature must be higher than the ambient temperature. The performance of a chiller can be given at many different ambient temperatures, but the industry norm is to use 95°F.

- **Water Cooled Chillers:**

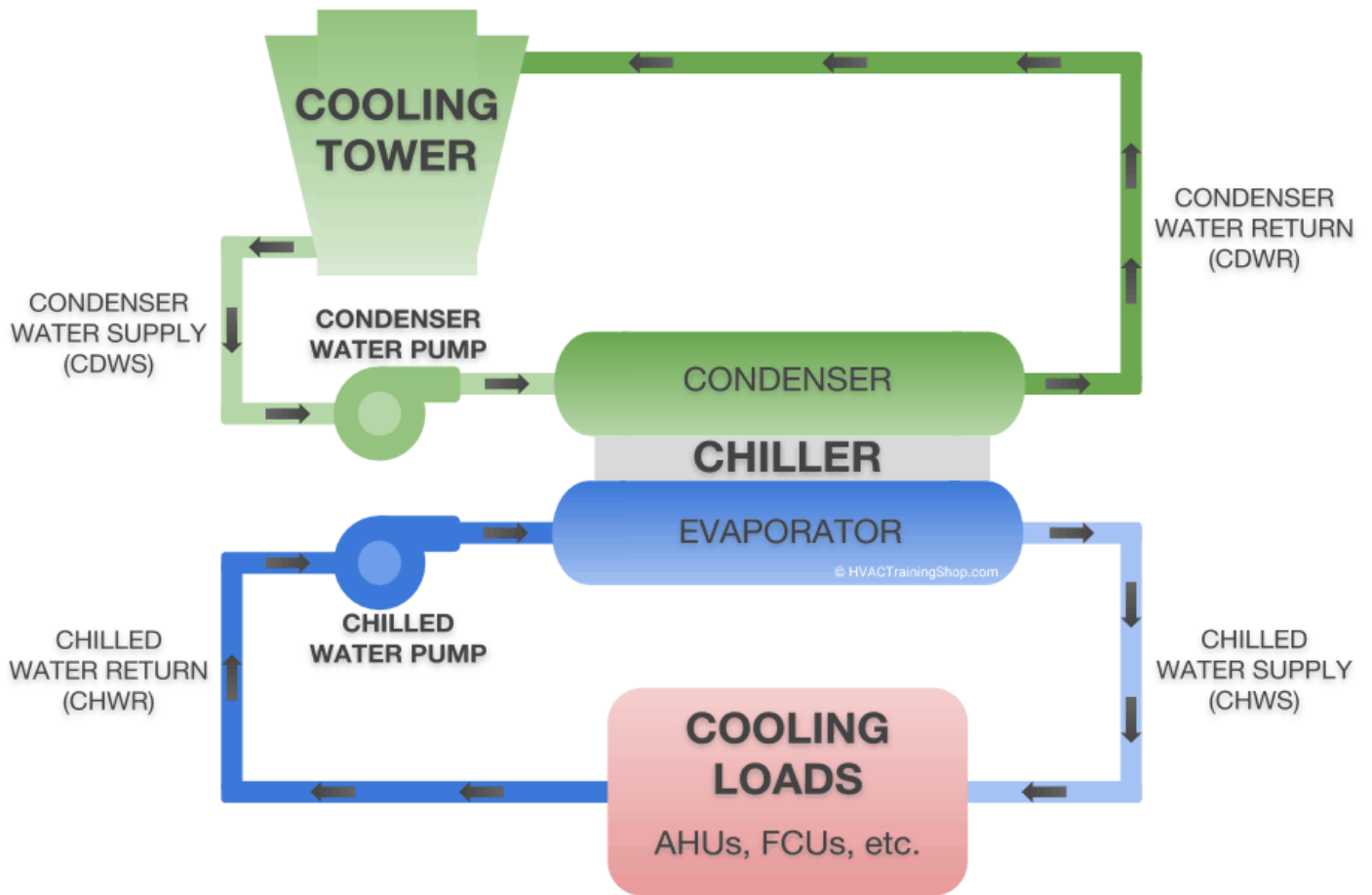

Figure 3.4: Water Cooled Chillers

CONSTANT FLOW CHILLED WATER SYSTEM

A constant flow system is the simplest chilled water distribution scheme. Here, a set of constant speed pumps distributes fixed quantity of water at all times and the temperature varies to meet the load. The system uses 3-way control valves at air handler coils that allow some water to bypass the cooling coil during part load conditions. At low loads, the chilled water flow through the cooling coil is restricted (in response to supply air temperatures to the space) but the total quantity returned to the chiller remains constant. Figure below shows the schematic of the constant-flow rate primary system.

Looking at the equation that governs heat transfer, the capacity of a chiller is proportional to the product of flow rate and the temperature difference of entering and leaving chilled water, or chiller capacity (BTU/hr) = GPM x 500 x ΔT . In constant-flow systems, flow rate (GPM) is established for peak design condition and ΔT (the difference between the chiller supply and return) varies in response to the load (BTU/hr). In air-conditioning applications, since the design conditions occur only during 1% of the operational hours in a year [i.e. 99% of the time the system runs on part load], some of the chilled water will always bypass through the three-way valve for most of coil's operational life. Higher quantities of bypassed chilled water mixes with leaving water from the cooling coil yielding lower chilled water return temperature to the plant. The lower return water temperature reduces the operating temperature differential (ΔT) across the chiller as the supply water temperature is fixed to a setpoint. This phenomenon is termed "Low delta – T syndrome" in HVAC industry.

Full Load Conditions

Figure below shows the peak design conditions where chilled water is entering the cooling coil at 44°F and leaving the cooling coil at 56°F. At full load 100% of chilled water @ 200 GPM will flow through the coil and 3-way bypass valve will not allow any water to bypass.

Off Load Conditions

Consider off -peak conditions, when the actual load drops to 50%. As the LOW load is sensed by the leaving air temperature thermostat, the 3-way valves restrict water supply to the cooling coil, allowing some chilled water @ 44°F to bypass directly into the return line water stream temperature of 56°F.

PRIMARY / SECONDARY DISTRIBUTION SCHEME

ASHRAE/IES Standard 90.1- 1989 - Energy Efficient Design of New Buildings Except Low-Rise Residential Buildings requires "all HVAC hydronic systems having a total pump system power exceeding 10 hp must be capable to flow at 50 % of design value or less." This standard highly recommends use of primary/secondary system for large complexes. A primary- secondary pumping scheme divides the chilled water system into two distinct circuits (loops) that are hydraulically separated by a neutral bridge (de-coupler).

1. Primary circuit is the place where chilled water is produced and its principal components are the chiller and pumps. The primary pumps are typically constant volume, low head pumps intended to provide a constant flow through the evaporator of the chiller. These are usually placed in tandem with each chiller though can also be arranged in common header.

2. The secondary circuit is responsible for the distribution of the chilled water to the terminal units. Among the components of the secondary circuits are pumps, terminal units such as fan-coils and air handling units (AHU) and control valves. The secondary pumps can be constant speed or variable speed and are sized to move the flow rate and head intended to overcome the pressure drop of secondary circuit only.

3. The neutral bridge consists of two tees that are typically located at the suction header of the secondary pumps and at the suction header of the primary pumps and connected by a de-coupling pipe. This de-coupler separates the primary and secondary loops. This common pipe is designed for negligible pressure drop at design flow. A well designed, low-pressure- drop common pipe is the heart of primarysecondary pumping, allowing the two pumps to operate independently.

CONSTANT PRIMARY & CONSTANT SECONDARY ARRANGEMENT

Refer below for a schematic of constant primary and constant variable system. It consists of one set of constant speed primary pumps and one set of constant speed secondary pumps. Constant flow primary/secondary chilled water system Primary pumps are lower horsepower than the secondary pumps because they only have to overcome the friction loss associated with the chiller, pipes, and valves in the primary loop. The secondary pumps, in contrast, are higher horsepower because they must overcome the friction loss associated with the secondary loop: the distribution piping, fittings, valves, coils, etc. The secondary loop contains 3-way valves to vary chilled water quantity through the coil in response to load but

the total quantity of flow in secondary loop remains the same. One of the salient features of a primary/secondary pumping schemes is to allow different chilled water flow rates as well delta-T on the two loops.

Example

Consider the same example of scheme 1, with a difference that the scheme is converted to primary/secondary arrangement and 4 x 300 GPM constant volume pumps added in secondary loop.

Consider the case when the building is experiencing just the 50% of the load i.e. 300 TR. The inherent separation of the primary and secondary loops allows two different flows in these circuits because both circuits are hydraulically independent. This way the system face the variable thermal load without having to keep all chillers “on-line” and pumping energy saving are realized during periods of low loads.

Flow in primary circuit

A 50 % drop in load could be faced with two chillers, with around 67 % [33.33% + 33.33%] of the total production flow of the plant. The flow in the primary circuit will be 800 GPM and the secondary loop continues to circulate 1200 GPM. Compared to constant volume systems, it is definitely a more efficient strategy than keeping in service all production units and theirs pumps at all loads.

Flow in secondary circuit

The primary chiller sequencing does not really change the secondary loop flow rate, which remain constant and higher percent than actual load. At 50% off-load conditions, 600 GPM is required for 300 TR load but 1200 GPM delivered through 4 x 300 secondary pumps. This wastes energy at low loads. It has another disadvantage. The excess flow will simply run through the common pipe in the direction towards the secondary pumps creating a mixing point and further degradation of the supply temperature. This reduces the cooling capacity of the coils, especially latent cooling capacity which could mean a loss of humidity control in the zones.

CONSTANT PRIMARY/ VARIABLE SECONDARY SYSTEM

In primary/secondary systems, water flows through the chiller primary loop at a constant rate, and water flows through the secondary loop, which serves air handlers or fan coils, at a variable rate. The constant speed pumps in secondary circuit are replaced with “variable speed” pumps. The speed of the secondary pumps is determined by a controller measuring differential pressure (DP) across the supply-return mains or across the selected critical zones. The decoupled section isolates the two systems hydraulically. Also the system uses two-way valves in the air handlers that modulate secondary loop flow rate with load requirements. During light load condition, the 2-way control valves will close (partially or fully) in response to load conditions, resulting in pressure rise in the secondary chilled water loop. A differential pressure sensor measures the pressure rise in the secondary loop and signals variable frequency drive of secondary pumps to alter the speed (flow). Primary-secondary variable-flow systems are more energy efficient than constant-flow systems, because they allow the secondary variable-speed pump to use only as much energy as necessary to meet the system demand.

Chilled water systems are generally comprised of the following major system components.

a. Chillers. The most common chilled water air-conditioning system is a single compressor and refrigerant circuit using a water-cooled condenser. It is relatively simple and compact. Compression type refrigeration liquid chilling equipment ranges in size from quite small to those with capacities in the thousands of tons (1 ton equals 12,000 BTU per hour of cooling). The three categories of chillers that will be discussed in this chapter are those which use



Figure 3.5: Water Cooled Chillers

reciprocating compressors, centrifugal compressors, and rotary screw type compressors. Control of water chillers is typically based on the return water temperature. The return water temperature indicates the cooling load in the facility at any given time. The warmer the chilled water return temperature, the larger the facility cooling loads. Occasionally, the chiller is controlled by the leaving water (supply) temperature. This is typical for process chilled water applications. In this case, the rotary screw compressor or the centrifugal compressor will usually respond best and will provide modulating control to meet the load.

(1) Reciprocating type chiller compressors are available in capacities from about 2 to 200 tons. Reciprocating water chillers may have one, two, or more compressors, each of which is matched to a separate tube circuit in a common shell, and each with its own expansion valve, service valves, dryer, piping, and controls. The compressors may be piped to use a common water-cooled condenser or may each have their own water-cooled condensers. Chillers are

also built with air-cooled condensers as part of a package for outdoor use, or can be built for use with a remote air-cooled condenser or an evaporative condenser. The principles of operation of all reciprocating compressors are much the same. Suction gas (from the evaporator) is drawn into the compressor through the suction shutoff valve to the suction chamber and on through a suction filter. The filter separates the lubricating oil from any liquid refrigerant that is mixed with the refrigerant gas. Since reciprocating compressors are made to pump refrigerant gas only, any liquid refrigerant must be separated from the gas to keep from doing any damage to the compressor valves. The gas then flows through the crankcase and then to the cylinders. The piston in the cylinder compresses the refrigerant that is discharged through the discharge opening. Water chillers which use reciprocating type compressors are of three main groups: hermetic, semi hermetic, and open direct drive type.

(a) A hermetic unit uses a hermetic compressor with the electric motor totally enclosed in the refrigerant atmosphere. The possibility of refrigerant leakage to the outside through a shaft seal is totally eliminated, and motor operating noise is subdued by the housing. Because this type of forced refrigerant cooling of the motor is very effective, smaller, less expensive motors can be used. The need for a heavy external base to preserve motor-compressor shaft alignment is eliminated. Hermetic machines are less expensive than external drive machines, have slightly greater power consumption, and are quieter. However, should the motor fail, the repair cost is higher, and the unit must be replaced with a like unit or sent back to the manufacturer for service. These compressors are used in most cases for small refrigeration or air-conditioning system.

(b) The semi hermetic compressor, like the hermetic type, has both the compressor and its drive motor in the same casing. The term "semi hermetic" means that the case in which both the compressor and motor are sealed may be opened for service or repair.

(c) Open direct drive type compressors are those in which the crankshaft, which is fitted with a shaft seal, extends from the housing. They do not have a drive motor as an integral part, but the drive motor in most cases is placed on the same base with the compressor. The motor may be joined to the compressor with a direct drive coupling or belt drive.

(2) Centrifugal compressors which are used as part of many large refrigeration and air-conditioning systems move a large volume of refrigerant at low pressures. They are made in sizes as great as 10,000 tons. The only wearing parts in a centrifugal compressor are the main bearings and the main seals. However, hermetic type centrifugal chillers do not have main

seals. All centrifugal compressors do not have pistons. In this type of compressor, the refrigerant gas from the evaporator is pulled through the suction line into the center of the impeller. The impeller which is rotating at a high speed forces the gas flow to the outside edge of the impeller and out the impeller housing. The hot, high pressure refrigerant gas then flows to the condenser. A centrifugal compressor may have one or more stages. These stages may be in the same or in separate impeller housings.

(3)The rotary screw type compressor uses a mated pair of special helical rotors. They trap and compress the refrigerant gas as they revolve in an accurately machined compressor cylinder. The helical rotors are made with the mate rotor having four lobes and the female rotor having

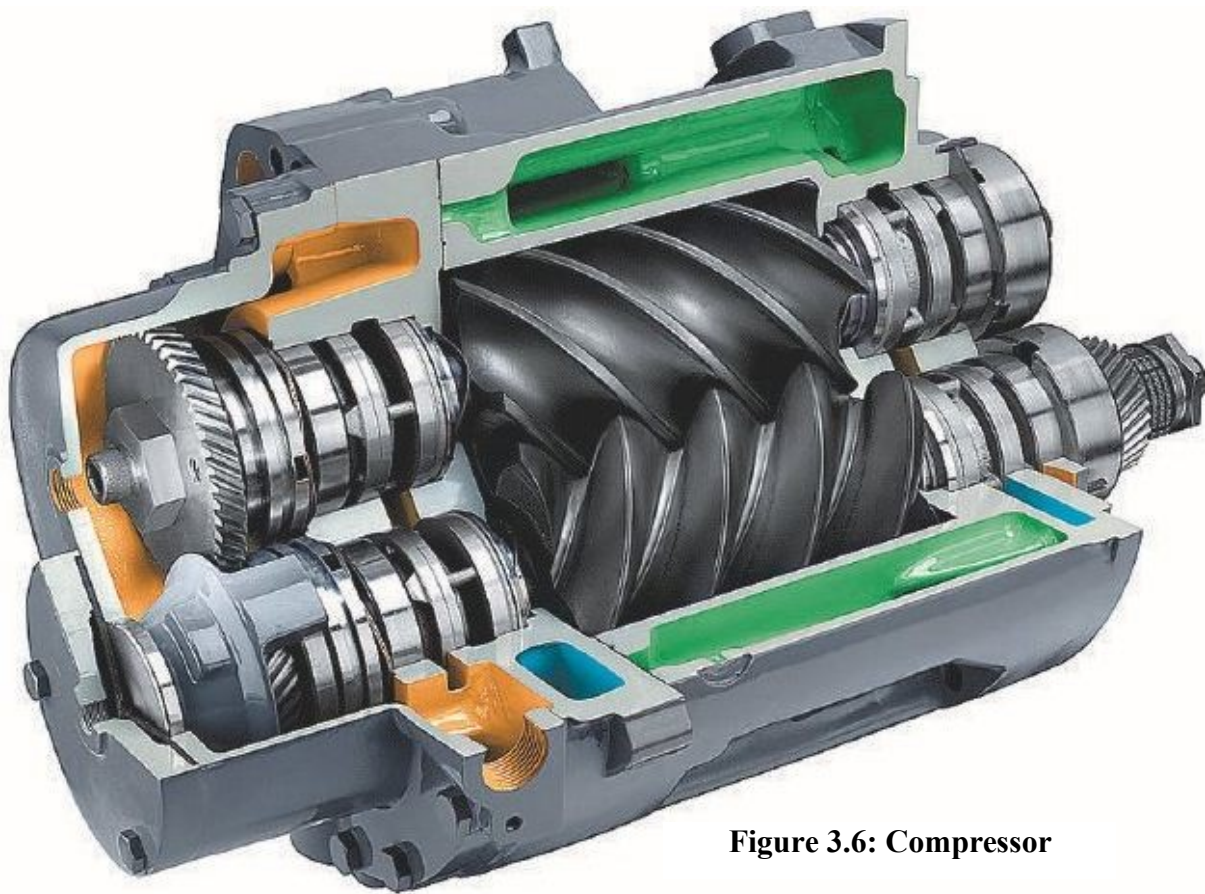

Figure 3.6: Compressor

six interlobe spaces. The male rotor often drives the female rotor, but in some cases they are both gear-driven. These compressors are built in either external drive or semi hermetic construction. They are used in larger systems that range in size from 20 to 800 tons. These compressors are commonly used with R-134a, R- 22, and R-717 (ammonia) refrigerants. An oil injection system is used that gives high-efficiency and smooth operation. As the lobe of the male rotor starts to unmesh from an interlobe space of the female rotor, a void is made and gas is drawn in through the inlet port. As the rotors continue to turn, the interlobe space increases in size and more gas flows into the compressor. Just prior to the point at which the

interlobe space leaves the inlet port, the entire length of the interlobe is filled with refrigerant gas. As rotation continues, the trapped gas in the interlobe space is moved circumferentially around the compressor housing at a constant pressure. Further rotation starts the meshing of another male lobe with the female space on the suction end and progressively compresses the gas in the direction of the discharge port.

Thus, the occupied volume of the trapped gas within the interlobe space is decreased, and the gas pressure as a result increases. As this gas is discharged, a fresh charge of refrigerant is drawn through the inlet on the opposite side.

b. Water chiller auxiliary system : Auxiliary systems used to enhance chiller performance and to aid maintenance activities include the following.

(1) Purge units are required for centrifugal liquid machines using low pressure refrigerants (such as R-123), because evaporator pressure is below atmospheric pressure. If a purge unit was not used, air and moisture would accumulate in the refrigerant over time. These non condensables drastically reduce the capacity and efficiency of the chiller operation. A purge unit is designed to prevent the accumulation of non condensables and ensure internal cleanliness of the liquid chiller. Purge units may be manual or automatic, compressor-operated, or compressor less.

(2) A refrigeration transfer unit may be provided for centrifugal liquid chillers using refrigerants with a boiling point below ambient temperature at atmospheric pressure (R-134a, R-22). This system is used for adding and removing refrigerant to and from the chiller. The unit consists of a small reciprocating compressor with electric motor drive, a condenser (air-cooled or water-cooled), an oil reservoir, an oil separator, valves, and interconnecting piping.

(3) Air-conditioning equipment is generally selected on the basis of maximum design condition and is then expected to cope with a variety of conditions, some of which may force the equipment outside of its stable operating range. At light cooling loads, operating the chiller at its maximum capacity will cause frosting of the coil, excessive compressor cycling, and possible liquid carryover. Hot gas bypass is a system that, at some predetermined partial loading, allows flow of hot refrigerant gas from the high pressure side to the low-pressure portion of the refrigerant system. This reduces the condenser capacity to produce refrigeration, because the gas returned to the low-pressure side produces no useful cooling;

instead it becomes an evaporator load. This enables the chiller to operate over a broader range of conditions and avoid freeze-ups and cycling problems.

3.2.2 Fan Coil Units

A fan coil unit (FCU) is a simple device consisting of a heating or cooling coil and fan. The fan is a centrifugal type driven by electric motor with fan mounted on the rotor shaft. FCU's can be both ducted or without ductwork as required by its application. The capacity of an FCU ranges from 100-2000 CFM.



Figure 3.7: FCU Unit

The chilled water from the Chillers is pumped into the coil of the FCU which cools up the coils. The blower or fan blows the air thru the coils thus reducing the temperature of the air as required. These are normally placed in the false ceilings randomly as per the zones to supply conditioned air.

3.2.3 Pumps

Pumps are devices used to force the fluid movement thru the piping system.

Types of Pumps:

- Centrifugal Pumps
 - a) Horizontal Centrifugal Pumps
 - b) Vertical Centrifugal Pumps
- Reciprocating Pumps
- Rotary Pumps

Pumps: The type of pump used to distribute chilled water through the chilled water system varies with the system design. There are two basic types of pumps: positive displacement and centrifugal.



(1) Positive displacement pumps trap the liquid in internal cavities and move it from the inlet of the pump to the discharge. This action increases the velocity and pressure of the liquid which flows in the discharge pipe. Positive displacement pumps are rarely used in chilled water systems.

(2) Centrifugal pumps are the most commonly used pumps in refrigeration and air-conditioning systems and are classified by their mechanical features, installation arrangement, mounting position, and method of connection to the electrical motor, figure 11-1 shows several types of centrifugal pumps. Centrifugal pumps have three main parts: a prime mover (typically electric motor), an impeller, and a body. The motor is often connected to the pump shaft by a flexible type coupling. Some centrifugal pumps are built with the motor and pump impeller on the same shaft. In all cases, the pump impeller is connected to the shaft and turns the same speed as the motor. The impeller is the part of the pump that causes the water to move through the pump body. Impellers vary widely in their construction.

The centrifugal force that comes from the rotating impeller moves the water or other liquids through the channels that run between the vanes. The outward-moving water streams are directed by the volute in a single stream that flows out of the pump discharge. This action of the impeller builds up the pressure of the water at the pump outlet.

SUCTION	DISCHARGE
END	TOP
TOP	TOP
SIDE	SIDE

Table 3.1: Nozzle Configuration for Pumps

3.2.4 Diffusers

Diffusers are the terminal units located in each space/room to be provided with conditioned air. They are placed in the center of each room for proper distribution of air to every corner.

They are different types of diffusers as per the directions of flow like,

- One Way Diffuser



- Two Way Diffuser



- Three Way Diffuser



- Four Way Diffuser



- Circular Diffuser



The other equipments used in here include Volume control dampers, Smoke dampers as per the requirement of the flow of air. They are sized as per the sizes of the duct as done in the next chapter.

Expansion Tanks: Expansion tanks are used in chilled water systems for two purposes. First, expansion tanks allow for thermal expansion of the chilled water that, if not for the expansion tank, could damage the piping system. Secondly, the expansion tank provides a location for makeup water to be admitted to the system. The expansion tank is connected to the chilled water system on the inlet (suction) side of the distribution pump(s) by a branch line. The makeup water line is typically connected to this branch line between the expansion tank and the main pump inlet pipe.

Control Valves: Control valves are used in chilled water systems to control the flow of chilled water through the piping system. The control system positions the valve through a valve operator or actuator that is directly attached to the valve stem. The valve operator or actuator uses electricity, compressed air, or hydraulic fluid to move the valve stem through its operating range.

Thermal storage: Thermal storage is the temporary storage of high- or low-temperature energy for later use. The purpose of thermal storage is to lower overall energy costs by generating and storing cooling medium during periods when electrical rates are at their lowest (off-peak). This occurs typically during the night or during periods of light air-conditioning load

(1) There are two types of storage strategies: full storage and partial storage. In full storage systems, the entire cooling load for a design period of time is generated during the off-peak time and stored for use during the following design period. In partial storage systems, only a portion of the design period cooling load is generated and stored during the previous off-peak period. During the peak period, the cooling load is satisfied by simultaneous operation of the cooling equipment (chillers) and withdrawal from storage.

(2) There are two thermal storage system options available for large commercial and industrial cooling applications: chilled water storage and ice storage.

(a) Chilled water storage systems use conventional chillers, pumps, and piping systems. They also require large storage tanks for chilled water. In this system, chilled water is generated during off peak periods and stored in a storage tank. During peak cooling periods, the stored chilled water is pumped from the tank to the cooling equipment (air handler coils, etc.) and then returned to the storage tank.

^ There are several types of ice storage systems that are used to store thermal energy. Ice storage typically has the advantage over chilled water storage in that it requires less space.

Heat exchanger: A heat exchanger is any device that affects the transfer of thermal energy from one fluid to another. In the simplest exchangers, the hot and cold fluids mix directly; more common are those in which the fluids are separated by a wall. Common heat exchangers include the flat-plate, shell and- tube, and cross-flow types. A double -pipe heat exchanger, the simplest form of the shell-and-tube, can have the fluids both flow in the same direction. It is referred to as a parallel-flow type. If they flow in opposite directions, it is referred to as a counter-flow type. A shell-and-tube exchanger may also have several tubes, two-passes, and baffles. In cross-flow heat exchangers, the fluids flow at right angles to each other. The evaporator and condenser sections of water chillers are examples of shell-and-tube type heat exchangers that are an integral part of the water chiller package. Heat exchangers are also designed and used as stand-alone thermal heat transfer devices in chilled water systems, heating water systems, and steam systems.

Strainers: Strainers are defined as closed vessels with cleanable screen elements designed to remove and retain foreign particles down to 0.001 inch diameter from various flow fluids. A strainer differs from a filter in that strainers trap particles that are typically visible to the naked eye. Strainers are typically installed in chilled water systems on the inlet (suction) side of the distribution pumps.

Air separators: All chilled water systems use air separators to remove air (gas) bubbles that have become entrained in the water. One type of air separator is simply a tank constructed so that the chilled water inlet is not in a direct line with the outlet from the tank. The diameter of the tank is large compared to the chilled water piping. As the chilled water enters the expansion tank, the flow is slowed down considerably. This slowing of the flow, together with the change in direction of the chilled water flow, allows the air to rise to the surface of the tank or into the expansion tank to be vented. A more common type of air separator is a mechanical type air separator with a tangential entry that causes the chilled water to spin down from an upper entry to a tower discharge. The resulting turbulence enhances the air separation. Tangential entry mechanical separators generally require less space than tank type separators, but require that the circulating pump be capable of producing higher differential pressures. The air separator is typically installed in the chilled water supply piping between the chiller and the distribution pump. Air separators should be fabricated, tested, and certified

in accordance with the appropriate sections of the American Society of Mechanical Engineers (ASME) Boiler and Pressure Vessel Code for unfired pressure vessels.

Valves: Valves installed in the chilled water system are used to control water flow and to isolate equipment for ease of maintenance. Most valves in a chilled water system are manually operated with a hand wheel or lever operator.

Valves are typically installed at the following locations.

(a) On the inlet and outlet connection of each piece of equipment, including chillers, pumps, reducing valves, control valves, tanks, coils, and other equipment that requires periodic maintenance.

(b) On the supply and return branch lines at the point of connection to the main supply and return piping headers.

(c) Drain valves are installed at low points in the water distribution system to facilitate draining of the system.

(d) Vent valves should be installed at all high points in the chilled water piping system for manual venting of air from the system and to help in the draining of the piping.

(3) The most common types of valves utilized in chilled water systems include gate, ball, butterfly, globe, check, and pressure regulating valves.

a) Gate valves are identified by a wedge-shaped disk that is raised to open or lowered to close the valve. Gate valves are intended to operate fully open or fully closed, and have very low resistance to flow in the open position, since the disk rises out of the flow path. The gate valve should not be operated in the partially open position, as this may cause vibration and premature wear on the disk. The gate valve may be used for shutoff service where a slow closure is acceptable and where an absolute bubble tight closure is not a critical consideration. Gate valves may be rising stem with outside screw and yoke (OS&Y), rising stem with inside screw, or non-rising stem. The rising stem type makes viewing of the valve position possible, while the non-rising stem type requires less clearance above the operator, since the stem does not rise from the body.

(b) Ball valves use a ball as the opening/closing mechanism to control fluid flow. The ball is rotated 90 degrees from full open to full closed; therefore, it is well-suited for applications

which require quick or frequent opening and closing. The ball seals by fitting tightly against resilient seats located on each side of the ball. Ball valves are generally selected for on/off service and are most common in sizes 3 inches or less. Ball valves are available in three port sizes, including standard, full, and reduced port. Full port has the same opening size as the connecting pipe, standard port is usually one pipe size smaller than the valve size, and reduced port may be up to two pipe sizes smaller than the valve body size.

(c) Butterfly valves in the chilled water system are most common in the larger sizes due to the ease of operation, low cost, and superior shutoff characteristics. The butterfly valve usually consists of a wafer-shaped body with a rotating disk that closes against a resilient seat located within the valve body. Like the ball valve, a 90-degree rotation of the operating mechanism results in valve travel from closed to full open. The butterfly valve is well-suited for both on/off service or throttling service.

(d) Globe valves are primarily used for throttling service and are not well-suited for full flow applications due to the high resistance to flow designed into the valve. The standard valve consists of a round disk or tapered plug that seats against a round opening. Angle valves and needle valves are variations of the standard globe valve and use a similar method of closure.

Unlike the gate and ball valves, globe valves must be installed in the proper direction of flow. Flow should enter through the disk seat and push up against the valve disk. Reverse installation will result in valve chatter, vibration, and premature valve failure.

(e) Check valves are used in the chilled water system to prevent reversal of flow at pumps and equipment, with swing checks and lift checks as the most common types. The swing check has a swinging disk that is held open by the fluid flow. Closure results from reverse flow and gravity acting on the disk. Lift check valves consist of a disk that is lifted by upward fluid flow. Reversal of flow pushes down on the disk, stopping flow. The swing check valve has less resistance to flow due to its straight through flow design, but is more prone to water hammer than the lift check. Swing and lift check valves generally are only suited for horizontal installations, unless specifically configured for vertical installation.

(f) Water pressure regulating valves are used in the chilled water system to limit the water supply pressure to equipment within acceptable levels. The two common types of water pressure regulating valves include the direct-acting type and the pilot-operated type. The direct-acting regulator consists of an inner valve connected to a diaphragm. The diaphragm is

held in position by a spring that is externally adjustable to give the desired downstream reduced pressure. The direct-acting regulating valve is simple and relatively inexpensive, but is not capable of maintaining constant downstream pressures if the upstream pressure varies or if the flow rate varies significantly. The pilot-operated regulator is more accurate than the direct-acting type, as it employs a small direct-acting valve (pilot valve) that maintains a constant pressure on the main valve diaphragm. Variations in upstream pressure have little effect on the resulting downstream pressure.

4. CHILLED WATER AIR-CONDITIONING SYSTEM

4.1 Chilled-Water Air-Conditioning System

A chilled water system is a means by which heat, generated in a space or by a process, is conveyed from that space and ultimately released to the outside. This chapter is intended to acquaint the facility operator with chilled water systems and identify a minimum level of maintenance activities that must be performed to maintain a chilled water system for continuous day-to-day operation. Each chilled water system is designed to transfer heat by the most efficient and cost-effective method. While there is no right way to design a chilled water system, chilled water systems have common characteristics and use common types of components. Due to these differences in chilled water systems, the

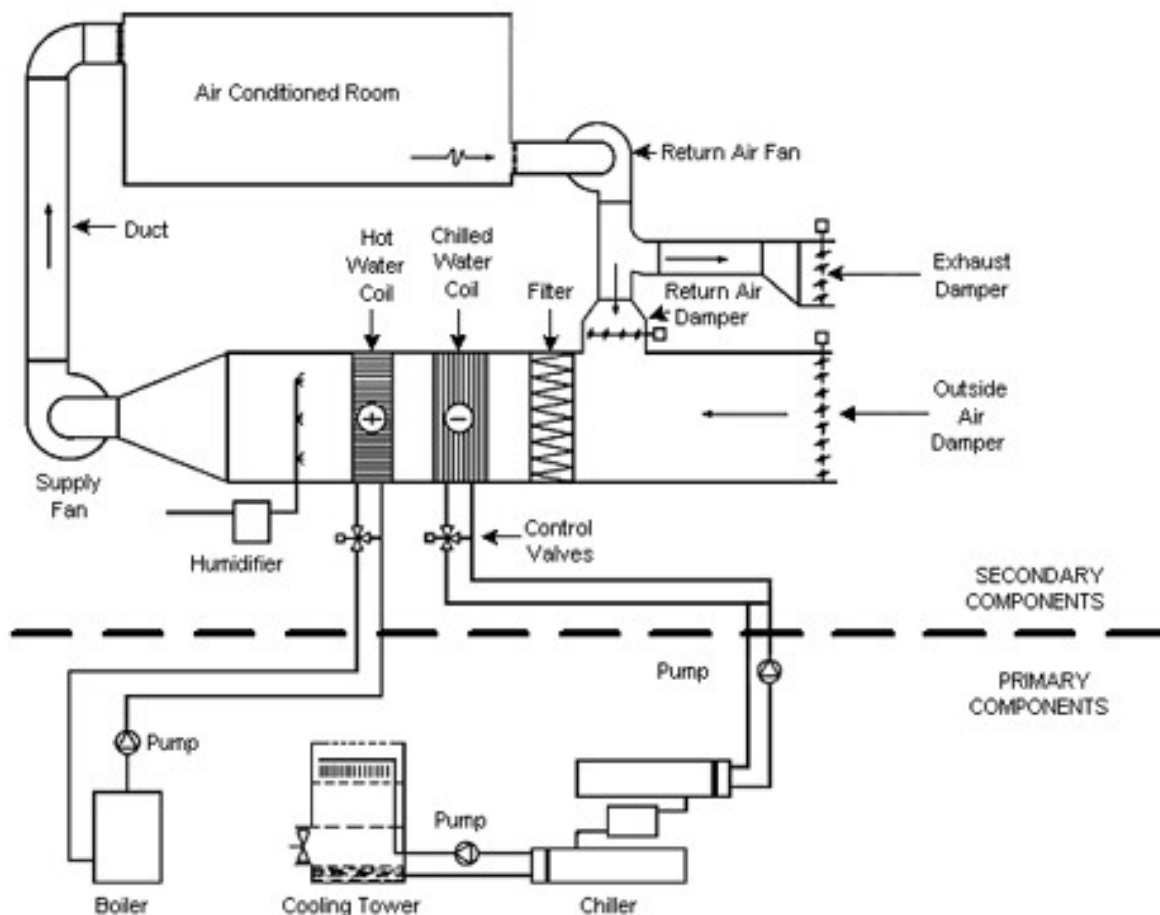

Fig 4.1 Schematic of HVAC System

individual chilled water system equipment manufacturer's directions regarding maintenance practices take precedence over any guidance provided in this chapter.

System Functions: Basically, a chilled water system circulates the chilled water through a loop piping system. Pumps force the water from the water chiller through the heat transfer components and back to the chiller via the piping system. Heat is transferred to the chilled water as it circulates through the heat transfer device that causes the temperature of the chilled water to increase. The portion of the system that supplies the water from the chiller to the heat transfer equipment is typically designated the chilled water supply system. Once the water is through this heat transfer equipment, the piping system delivering it back to the chiller is termed the chilled water return system.

Piping system: There are two common types of chilled water piping systems: two-pipe and dual temperature, with numerous variations of each. Two-pipe systems for comfort air conditioning typically operate with a design supply temperature of 40 to 55oF and a system pressure of approximately 125 psi. Antifreeze or brine solutions may be used for chilled water systems (usually process applications) that require supply temperatures below 40oF. In addition, well water type chilled water systems can use supply temperatures of 60oF or higher. Dual-temperature systems are a combined water heating and cooling system that circulate hot and/or chilled water to heat or cool with common piping and terminal heat transfer apparatus. This chapter will consider two-pipe chilled water systems that supply 40 to 55oF supply water only; however, much of the information presented in this chapter will apply to dual temperature systems as well.

4.2 Conceptual view of a chilled-water air-conditioning system

In this figure, thermal energy moves from left to right as it is extracted from the space and expelled into the outdoors through five loops of heat transfer:

- **Indoor air loop.** In the leftmost loop, indoor air is driven by the supply air fan through a cooling coil, where it transfers its heat to chilled water. The cool air then cools the building space
- **Chilled water loop.** Driven by the chilled water pump, water returns from the cooling coil to the chiller's evaporator to be re-cooled.
- **Refrigerant loop.** Using a phase-change refrigerant, the chiller's compressor pumps heat from the chilled water to the condenser water.

- **Condenser water loop.** Water absorbs heat from the chiller's condenser, and the condenser water pump sends it to the cooling tower.
- **Cooling tower loop.** The cooling tower's fan drives air across an open flow of the hot condenser water, transferring the heat to the outdoors.

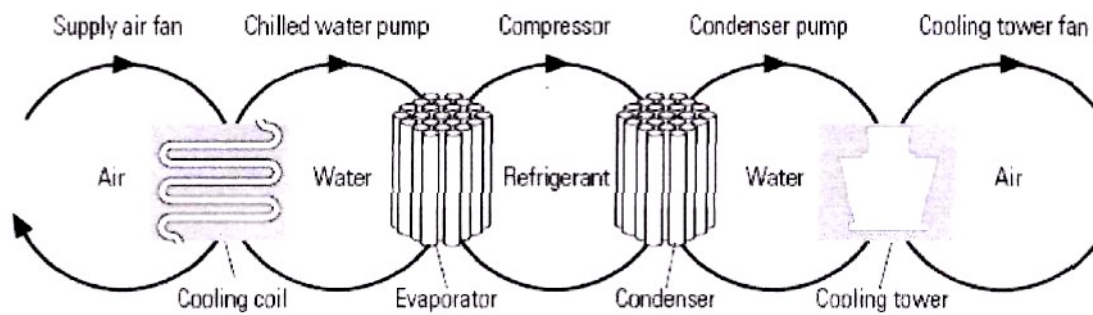

Fig 4.2 Chilled Water System

4.3 Waste Heat Rejection - Refrigeration Condensers

Chillers generate a large amount of waste heat. In a domestic refrigerator, which we have used as an example of an every day chiller previously, the waste heat is simply allowed to enter the kitchen via the condenser coil at the rear of the refrigerator. However, in air conditioning systems the amounts of waste heat involved are too great and would cause serious overheating in the plant room. Because of this the waste heat must be safely rejected outside the building. There are three main ways in which waste heat is removed from the condenser. These are by using; air cooled condensers, evaporative condensers or water cooled condensers.

Water cooled condensers. Variations in ambient air temperature cause changes in the efficiency of air cooled condensers. A more temperature stable heat sink is water. Water cooled condensers make use of this by jacketing the condenser in a shell which is filled with water.

The condenser passes its waste heat to the water increasing its temperature by about 5°C. The water is then pumped to a water to water plate heat exchanger. Water from a large nearby source, such as a canal, river, lake or sea is also circulated through this heat exchanger having first been strained and filtered. In this way the condenser cooling water only makes thermal

contact with the heat sink water. The heat sink water having picked up heat from the condenser circuit is returned to the main body of water where the heat it carries is dispersed. The condenser cooling water leaves the plate heat exchanger and returns once more to the condenser to pick up more waste heat. The use of bodies of water such as rivers and canals as a heat sink is subject to water authority approval.

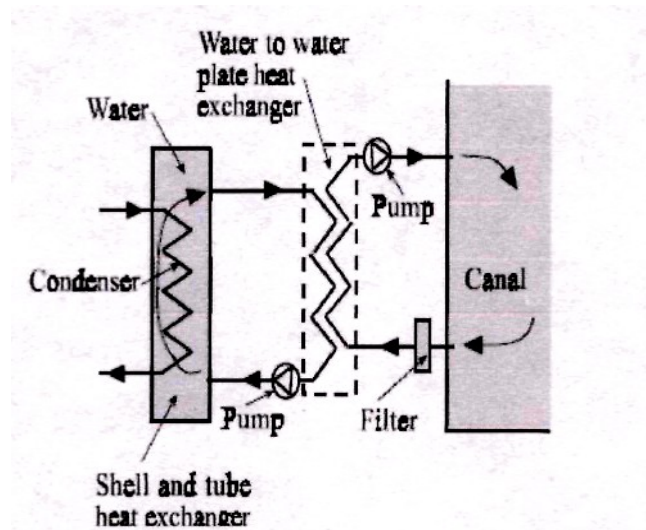

Fig 4.3 Water Cooled System

Cooling Towers. In locations where there are no large bodies of water that can be used as a heat sink, the water cooled condenser is used in conjunction with a cooling tower. A cooling tower is a device which cools the condenser cooling water by evaporation before returning it to the condenser to collect more heat. Figure shows a forced draught cooling tower. It can be seen that the condenser cooling water is allowed to tumble down through the device whilst air is forced upwards through the cascading water by a fan.

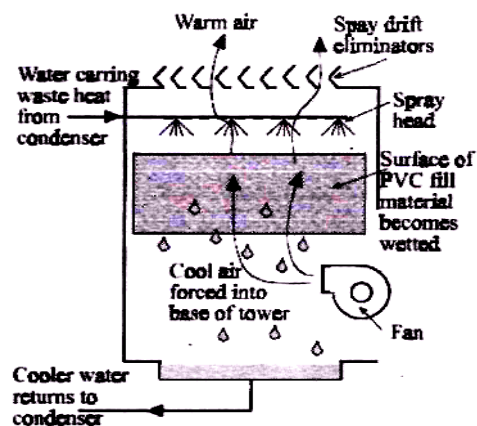

Fig 4.4 Cooling Tower

Evaporators:

Two types of evaporators are used in water chillers—the flooded shell and tube and the direct expansion evaporators (DX). Both types are shell and tube heat exchangers. Flooded shell and tube heat exchangers are typically used with large screw and centrifugal chillers, while DX evaporators are usually used with positive displacement chillers like the rotary and reciprocating machines. While water is the most common fluid cooled in the evaporator, other fluids are also used. These include a variety of antifreeze solutions, the most common of which are mixtures of ethylene glycol or propylene glycol and water. The use of antifreeze solutions significantly affects the performance of the evaporator but may be needed for low temperature applications. The fluid creates different heat transfer characteristics within the tubes and has different pressure drop characteristics. Machine performance is generally derated when using fluids other than water.

Flooded Shell and Tube

The flooded shell and tube heat exchanger has the cooled fluid (usually water) inside the tubes and the refrigerant on the shell side (outside the tubes). The liquid refrigerant is uniformly distributed along the bottom of the heat exchanger over the full length. The tubes

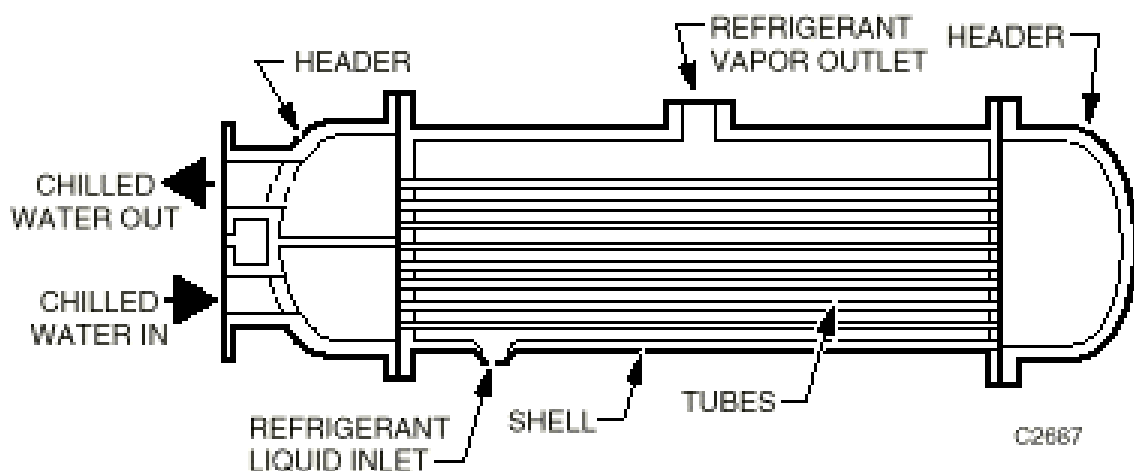

are partially

Fig 4.5 Shell and Tube Heat Exchanger

submerged in the liquid. Eliminators are used as a means to assure uniform distribution of vapor along the entire tube length and to prevent the violently boiling liquid refrigerant from

entering the suction line. The eliminators are made from parallel plates bent into Z shape, wire mesh screens, or both plates and screens. A *float valve* or *fixed orifice* maintains the level of the refrigerant. The tubes for the heat exchanger are usually both internally and externally enhanced (ribbed) to improve heat transfer effectiveness.

Direct Expansion

The direct expansion (DX) evaporator has the refrigerant inside the tubes and the cooled fluid (usually water) on the shell side (outside the tubes). Larger DX evaporators have two separate refrigeration circuits that help return oil to the positive displacement compressors during part-load. DX coolers have internally enhanced (ribbed) tubes to improve heat transfer effectiveness. The tubes are supported on a series of polypropylene internal *baffles*, which are used to direct the water flow in an up-and-down motion from one end of the tubes to the other.

4.4 Piping System

A Pipe is a cylindrical conduit used for the transportation of fluids and solids from one place to another under pressure.

Fluids: Liquid (Ex: Water) & Gas (Ex: Steam)

Solids: Ex: Powder & Pellets

Semi Solids: Ex: Slurry

Pipe Sizing

The Piping system in Centralized HVAC System is a closed type. The Closed systems are made up of two components:

1. a supply system that ends at a terminal air conditioning equipment unit
2. a return system that starts at the terminal equipment

Fig. 1-10 shows a closed system network. The system shown is a reverse return system with both supply and return sections. Closed systems are not affected by atmospheric pressure.

The

pump head of open systems include atmospheric pressure.

The calculation of size and the thickness (also called as Schedule Number) of a pipe can be done on the basis of Hydraulic Design & Pressure Design. For HVAC Systems carrying medium/atmospheric pressures, Hydraulic design is used. For higher pressures the pipe requires higher thickness, so Pressure design based on ASME codes will be applicable.

Designation of Pipe Size: Nominal Pipe Size (NPS) (OD of pipe in inches)

Designation of Pipe Thickness: Schedule Number (Wall thickness of pipe in Inches)

- **Stress Acting on a Pipe :**

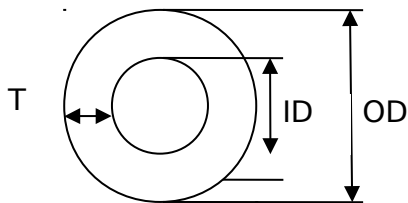

$$OD = ID + 2T$$

1. Hoop Stress/ Circumferential Stress: $S = P.D/2 t$
Where P is the Internal Pressure
D is Outer Diameter of the Pipe
t is the Pipe Thickness
2. Longitudinal Stress: $S = P.D/4t$
3. Radial Stress: $S = P$

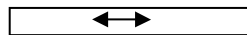
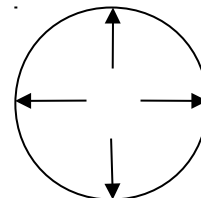

- **Pipe Length:**

Pipe length are commercially provided in as,

- Single Random Length = ± 20 ft or ± 6 m
- Double Random Length = ± 40 ft or ± 12 m
- Customised Length = As per customer requirement

- **Pipe Manufacturing Methods:**

Pipe are generally manufactured and commercialized as per following methods

- Seamless
- ERW (Electric Resistance Weld)
- EFW (Electric Fusion Weld)
- FBW (Fusion Butt Weld)
- SAW (Submerged Arc Weld)
- DSAW (Double Submerged Arc Weld)
- Spiral Weld

• **Pipe Ends:**

Pipe ends are generally made in as

- Threaded/Screwed ends
- Plain ends
- Bevelled ends (Angle 30-35°)

• **Pipe Joining Methods:**

- Threaded Joining Method
- Socket Weld Joining Method
- Butt Weld joining Method
- Flanged Joining Method

• **Piping Elements:**

The commonly used piping elements for both its flexibility and directional changes are

Elbow: An elbow is a pipe fitting installed between two lengths of pipe or tubing to allow a change of direction, usually a 90° or 45° angle.



Figure 4.6a: 90° Elbow



Figure 4.6b: 45° Elbow

Tee: It is used to either combine or split a fluid flow. It is a type of pipe fitting which is T-shaped having two outlets, at 90° to the connection to the main line.



Figure 4.6c: Tee

Reducer: A reducer allows for a change in pipe size to meet hydraulic flow requirements of the system, or to adapt to existing piping of a different size. Reducers are usually concentric but eccentric reducers are used when required to maintain the same top- or bottom-of-pipe level.



Figure 4.6d: Reducer

Other Elements:

Cap: A type of pipe fitting, usually liquid or gas tight, which covers the end of a pipe

Nipple: A nipple is defined as being a short stub of pipe which has external male pipe threads at each end, for connecting two other fittings. Nipples are commonly used for plumbing and hoses, and second as valves for funnels and pipes.

Valves: Valve is equipment designed to stop or regulate flow of any fluid (liquid, gas, condensate, stem, slurry etc.) in its path.

Coupling: A coupling connects two pipes to each other. If the size of the pipe is not the same, the fitting may be called a reducing coupling or reducer, or an adapter.

Union: A union is similar to a coupling, except it is designed to allow quick and convenient disconnection of pipes for maintenance or fixture replacement

Valves: The functions of valve include:

- Isolation (On/OFF)
- Throttling/Regulation/Control (of Volume & Speed)
- Control of direction





Types Of Valves	Figure	Applications
Globe Valve		Used for throttling
Gate Valve		Used for isolation only
Butterfly Valve		Used for isolation as well as throttling
Strainer		Used to remove foreign particles from the water, which can damage the pump.
Non-Return Valve/ Check Valve		Used for preventing reverse flow (non-return)

Table 4.1: Valves and Their Applications

Pipe Sizing:

The pipe sizing for a line can be done with following values :

For Air/Steam: Volume Flow rate (CFM) & Velocity (FPM)

For Water : Volume Flow rate (GPM) & Velocity (FPS)

Formula:

$$\text{GPM} = 2.4 \times \text{TR (Tonnes of Refrigeration)}$$

FPS is calculated basing on number of hours of operation per year

Ex: @HYD operating for 5 months per year = 5 months x 30 days x 24 hrs = 3600 hrs/year

Water Velocity:

- Roof Piping - 10 FPS
- Riser Piping - 8 FPS
- Floor Piping - 6 FPS

Normal Operation (Hr/Yr)	Water Velocity (FPS)
1500	12
2000	11.5
3000	11
4000	10
6000	9
8000	8

Table 4.2: Maximum Water Velocity to Minimize Erosion

The Pipe diameter values of each can be derived from the below chart as per the GPM and the velocity at the required at each point. These values are depicted on the drawing along with the GPM values for each FCU.

5. FINAL LAYOUTS

The Design values thus derived are implemented into AutoCAD, and the complete layouts are formed including equipment & piping for the project.

5.1 Piping Layouts

The piping layouts generally used in HVAC are

- Single Line Diagram
- Piping Plan Layout
- Schematics

(*Piping to be drawn on the project as per the sizes derived from the chart for Roof, Riser and Floor piping. Detailing as per standards).

As per the requirement of the project, the details Single line Piping layouts are given below as per the Floors. The Piping system provided is

- Chilled Water Supply (CHS)
- Chilled Water Return (CHR)

SL No	Floor Description	Dwg No.
1	Ground Floor	CW-01
2	First Floor	CW-02
3	Second Floor	CW-03
4	Roof Deck	CW-04

The Drawings as listed above are as follows:

6. CONCLUSION

Surely HVAC system has become a necessity for Human, the report elaborates the usage of water as a coolant for the centralized HVAC System. The Design of a Centralized Chilled Water Air-Conditioning System for the Corporate Office building done as per the standards of ASHRAE will be submitted for approval from the sponsored authority. The project report concludes that;

- The concept of Chiller water System is clearly explained with the importance of the system in HVAC Industry & Application.
- The main motive of design of an HVAC system for the building industry purely depends on the Human Comfort values, should be maintained irrespective of location of the project.
- The Heat Load Estimated provides the requirement of Cooling for the project, provides a guideline for the Selection of Machines.
- All the Equipments are installed as per the manufacturer's recommendations to achieve its best efficient performance.
- The Final Layouts for the Piping and Equipment are submitted for final approval, for the site Installation.

Thus the Project Report clearly identifies the requirements of the project and provides an effective way of Air-Conditioning to achieve Human comfort for the occupants. The design and drawings as approved will be sent to the site installation process. Therefore the project defines the requirement and process of achieving the Human Comfort and Environment.

7. BIBLIOGRAPHY

- **American Society of Heating Refrigeration & Air conditioning Engineer's**
 - **FUNDAMENTALS**
- **American Society of Heating Refrigeration & Air conditioning Engineer's**
 - **HAND BOOKS 2003**
- **Carrier Design Manual**
- **Trane Air Conditioning System Design Manual**