

ariazone

Automotive & Industrial Refrigerant Service Equipment

Automotive Air Conditioning Training Manual

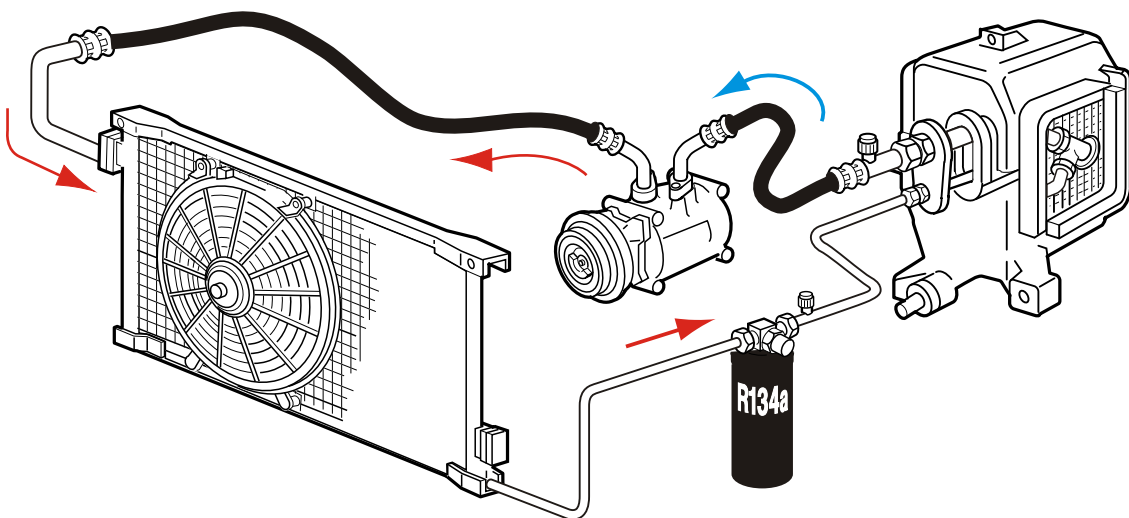

(I) Theory

The four major function.....3
 Understanding heat.....4
 Change of state.....7
 Pressure & temperature relationship.....8
 The Ozone Layer.....9
 R134a properties.....10
 Principles of air conditioning.....12

(II) System types

Expansion block valve system.....13
 Parallel flow condenser system.....14
 Orifice tube system.....15
 Expansion valve dual system.....16

(III) Components

Compressors.....17
 Clutches.....22
 Lubrication.....23
 Condensers.....24
 Foam seals.....25
 Condenser electric fans.....25
 Evaporators.....26
 Thermal expansion valve.....27
 Super heat.....29
 Orifice tube.....30
 Filter drier receiver.....31
 Accumulators.....32
 “O” rings.....33
 Hoses.....34
 Charging ports.....35
 Wiring A/C systems.....36
 Blower speed control.....37
 Compressor cycling control.....38
 Protective sensors.....42
 Temperature control.....48
 Mode control.....49
 Electronic temperature control (ECC).....51

(IV) Retrofitting

Introduction.....53
 Procedures.....54

(V) Equipment

Recovery&Recycling equipment.....	56
Evacuation equipment.....	57
Charging stations.....	59
Combination units.....	60
Refrigerant safety.....	61
Leak detections & detectors.....	62

(VI) Servicing

Lubrifications.....	65
Flushing a contaminated systems.....	66
Preparations.....	67
Testing conditions.....	68
A/C performance check.....	69
Faulty performance of A/C systems.....	72
A/C system to noisy.....	74
A/C system emits unpleasant odours	75
The condenser does not dissipate enough heat.....	76
Incorrect refrigerant amount.....	77
Compressor displacement regulation valve defective.....	78
Expansion valve defective.....	79
Electric compressor clutch slips or does not engage.....	80
Ice on the evaporator core.....	81
Compressor damaged.....	82
Hot air infiltrated in the passenger compartment	83
Blockage in the A/C system circuit	84

The four major functions

To be effective, the automotive air conditioner must control four (4) conditions within the vehicle interior:

It must cool the air



It must circulate the air

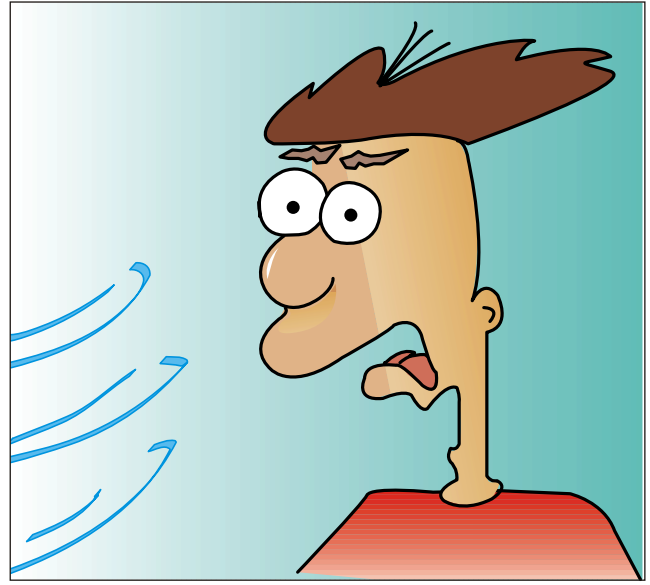

It must purify the air

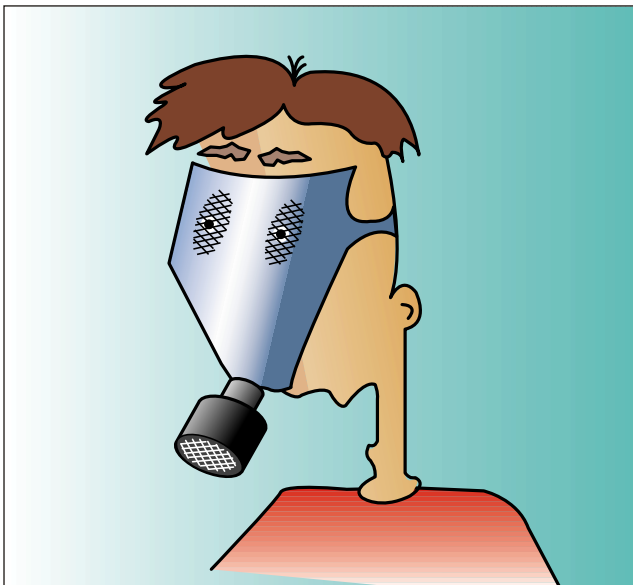

It must dehumidify the air



These functions are essential if passenger comfort is to be maintained when the ambient temperature and humidity are high. By performing these functions, the air conditioner maintains the body comfort of the passengers.

Understanding heat

What is heat?

To understand just how an air conditioning system works, we must first understand the nature of heat.

For a simple definition we may say that heat is energy. The meshing of gears, the turning of wheels cause friction which results in heat. Combustion (fire) gives off heat. The burning of sun radiates heat to the earth's surface.

Heat in the correct amount will provide life and comfort. Heat in either extreme - extreme to much or to little - will be uncomfortable.

The control of temperature means the control of comfort.
Air conditioning is a method of controlling heat.

When is heat hot?
When is heat cold?

All substances contain heat. Something "feels" hot when it is warmer than our body temperature. When something contains less heat than our bodies, we say it feels cold! Cold is merely the removal of some heat.

Science tells us that a measurement called "Absolute Zero" is the point at which all heat is removed from an object (approximately -273°C). Any substance above this absolute zero temperature retains some heat.

The burning of the sun radiates heat to the earth.

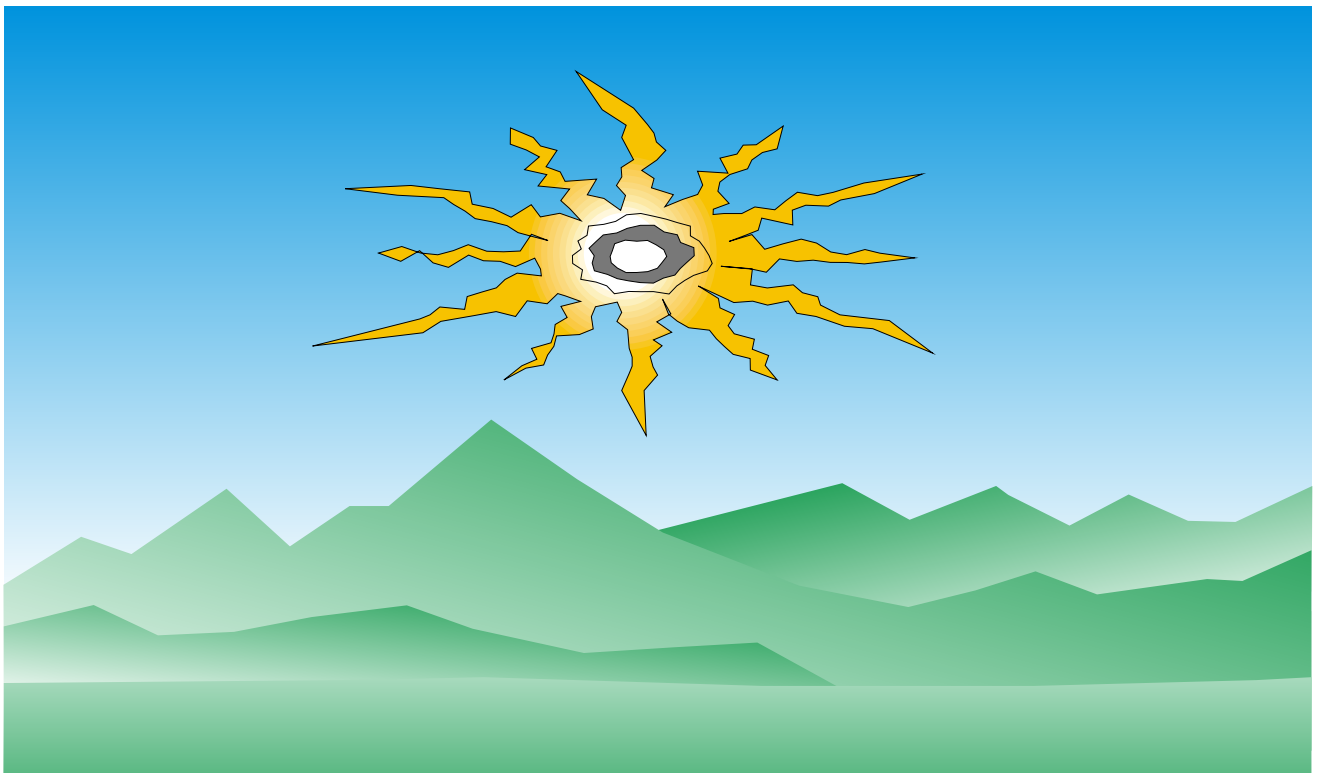

Understanding Heat

All substances contain heat

The average person requires a comfort zone of approximately 21°C to 26°C , with a relative humidity of 45 to 50%. In this temperature and humidity range, we feel most comfortable. All objects within this same range are comfortable to touch.

As the temperature of anything goes above or below this range, we think of it as **HOT** or **COLD**.



Heat measurement

A temperature reading gives us the heat intensity of a substance and not the actual quantity of heat.

Heat quantity is measured in "KILOCALORIES" (KCAL's). One KCAL is the amount of heat required to raise the temperature of one kilogram of water one degree Celsius (at sea level). This quantity measurement is used in air conditioning to describe heat transfer during changes of state.

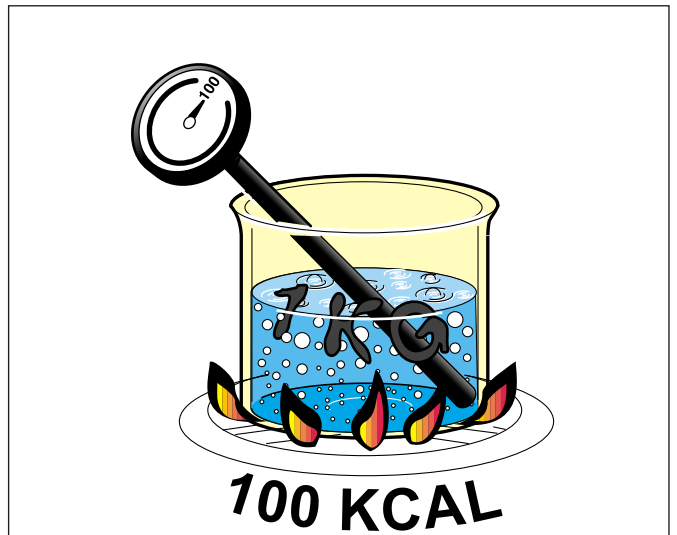

What causes heat to move?

Heat always moves from the hotter objects to the colder one. Whenever there is a transfer difference between two objects, the heat energy will be transferred from the warmer object to the cooler one until both objects stabilize at the same temperature.

This is known as the **law of heat transfer**, and is the basis of air conditioning operation.

When a hot cup of coffee is set aside for some time, it becomes cold. Heat moves out of the hot (90°C) coffee into the cooler (25°C) surrounding air. In time the coffee will reach the temperature of the surrounding air.

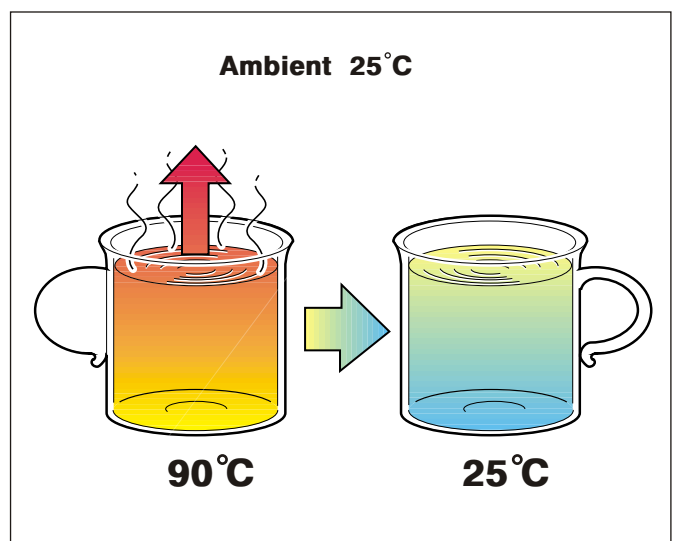

Understanding Heat

How does heat get inside a vehicle?

When a car is driven or parked in the sun, heat enters the vehicle from many sources.

These sources include:

- Ambient air
- Sunlight
- Engine heat
- Road heat
- Transmission
- Exhaust heat

All of these and other miscellaneous heat sources, increase the air temperature within the vehicle. In a high ambient temperature situation, (e.g. on a 37°C day), the interior of a vehicle left standing in the sun with windows closed could reach 65 - 70 °C!

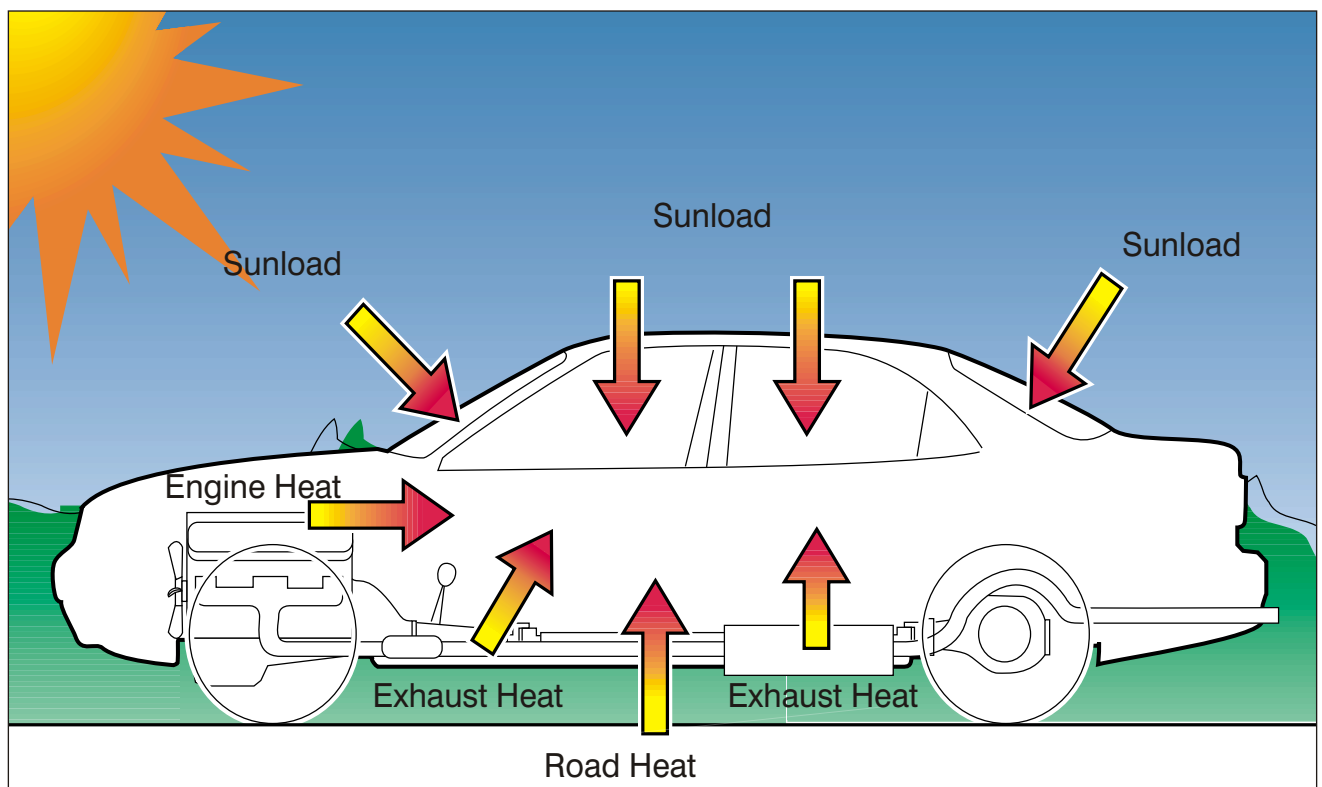

Changes of state

Evaporation

Is the term used when enough heat is added to a liquid substance to change it into a vapor (gas). For example, when water is boiled.

This condition occurs within the A/C system.

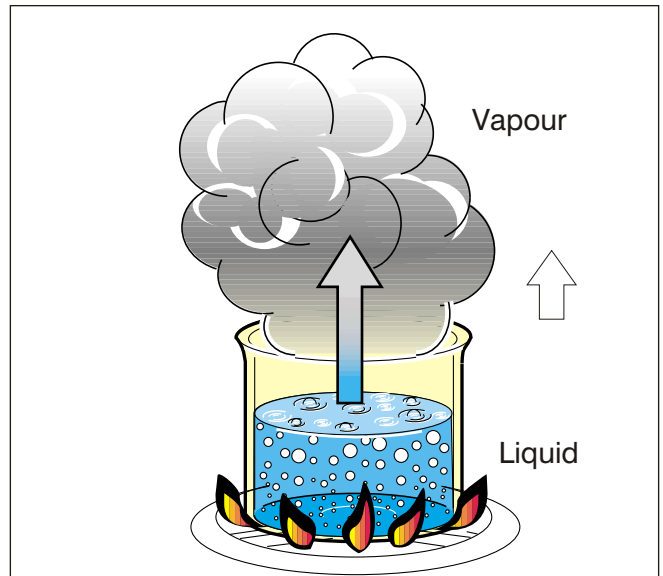

Condensation

Is the term used to describe the opposite of the evaporation process. If you take a vapor and remove enough heat from it, a change of state occurs. The vapor becomes a liquid.

The change of vapor to a liquid is called condensation.

This condition occurs within the A/C system.

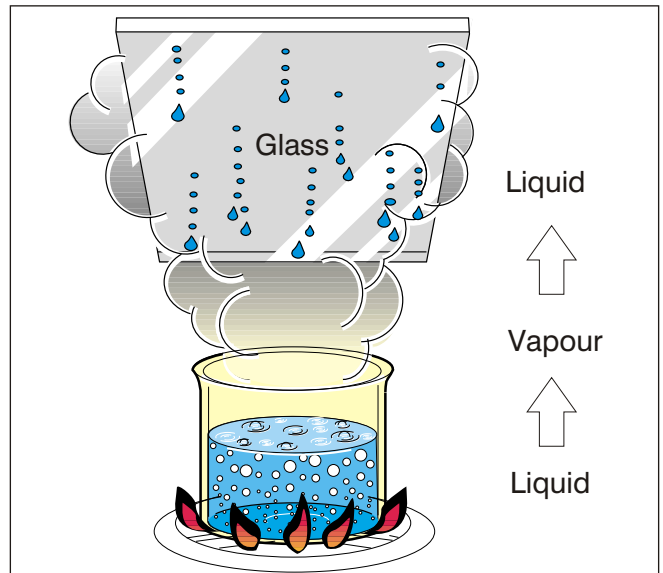

Freezing

Is another change of state. Freezing results when heat is removed from a liquid substance until it becomes a solid. Remember that anything above -273°C still contains some heat.

In an air conditioning system freezing must be avoided. Otherwise component damage will occur.

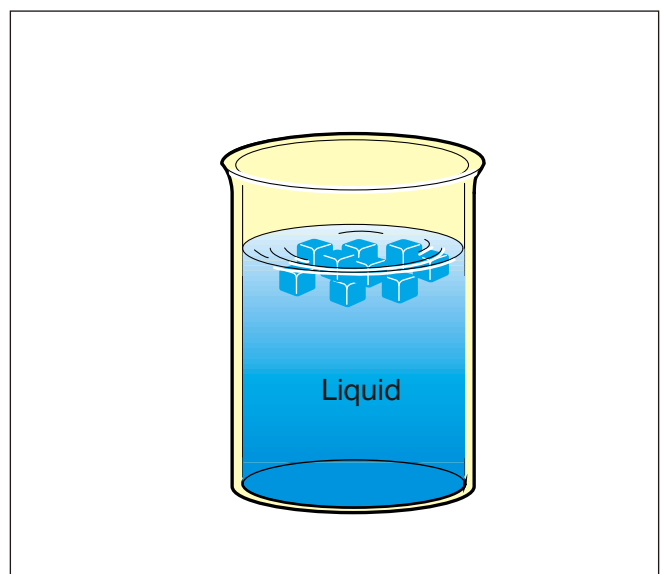

Pressure & temperature relationship

To increase or decrease the boiling point of a substance, we must alter the pressure on the substance. Increasing the pressure increases the boiling point.

To decrease the boiling point, decrease the pressure.

A good example is the automotive cooling system.

The pressure cap keeps the radiator from boiling over by increasing the pressure on the coolant.

Example:
110 kPa radiator cap allows the coolant temperature to reach 126°C before boiling.

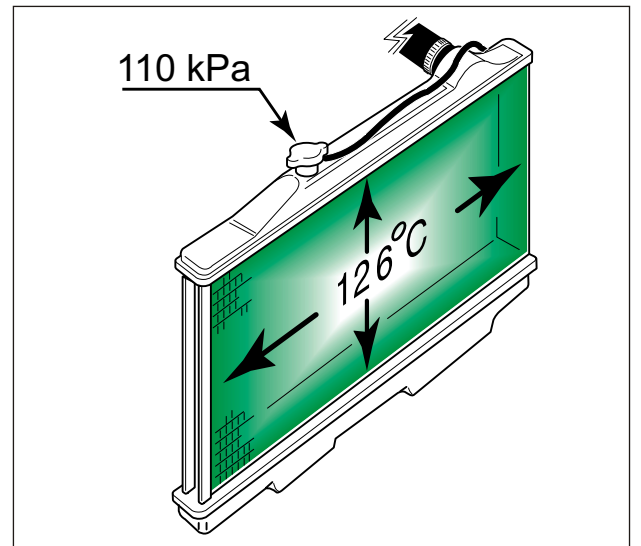
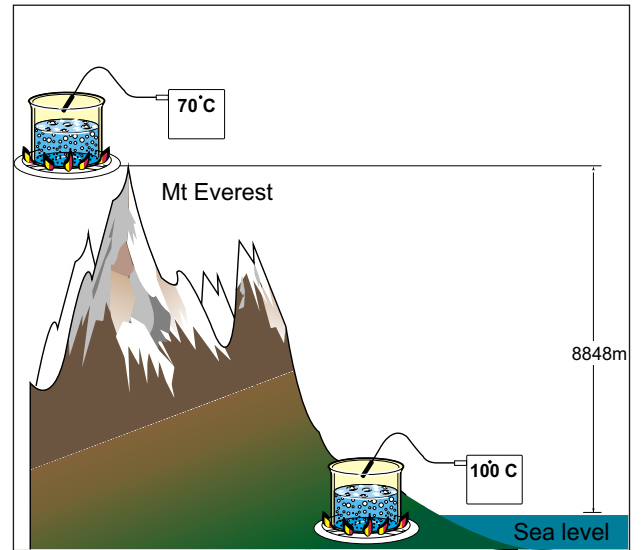

This chart opposite shows that the boiling point of water can be altered by changing the pressure upon it.

As a comparison with the radiator example above.

The substance used in the air conditioning system, called refrigerant, also boils at different temperatures depending on the pressure that it is under.

Boiling Point of Water			
Pressure above sea level (kPa)	temperature °C	Pressure above sea level (kPa)	temperature °C
0	100	82.7	120.1
13.8	103.4	96.5	123.1
27.6	106.8	110.3	126.8
41.4	110.1		
55.2	113.4		
69.0	116.8		

The ozone layer

Ozone (O₃) is formed in upper atmosphere (stratosphere), approximately 10 to 50 km above the earth surface.

This layer acts as a shield that protects the earth's surface from harmful ultra violet radiation coming from the sun.

The chlorine contained in CFC's rise into the ozone layer and destroys the ozone molecule O₃. Depletion of the ozone layer can be catastrophic to human life causing problems such as:

- Skin cancer
- Eye cataracts
- Reduced immunity to disease
- Damage to crops
- Reduced aquatic life

Background

1974 - It was first recognized that the use of chlorofluorocarbons (CFC's) was potentially having a detrimental effect on the ozone layer.

1987 - The Montreal protocol was adopted. This protocol called for restrictions on the manufacture and usage of CFC's to 1986 levels. From 1987 manufacturers could only produce the same quantities as produced in 1986.

1990 - A second Montreal protocol meeting was held and recommended a total phaseout of ozone depleting refrigerant by the year 2000.

2000 - Total phaseout of CFC's.

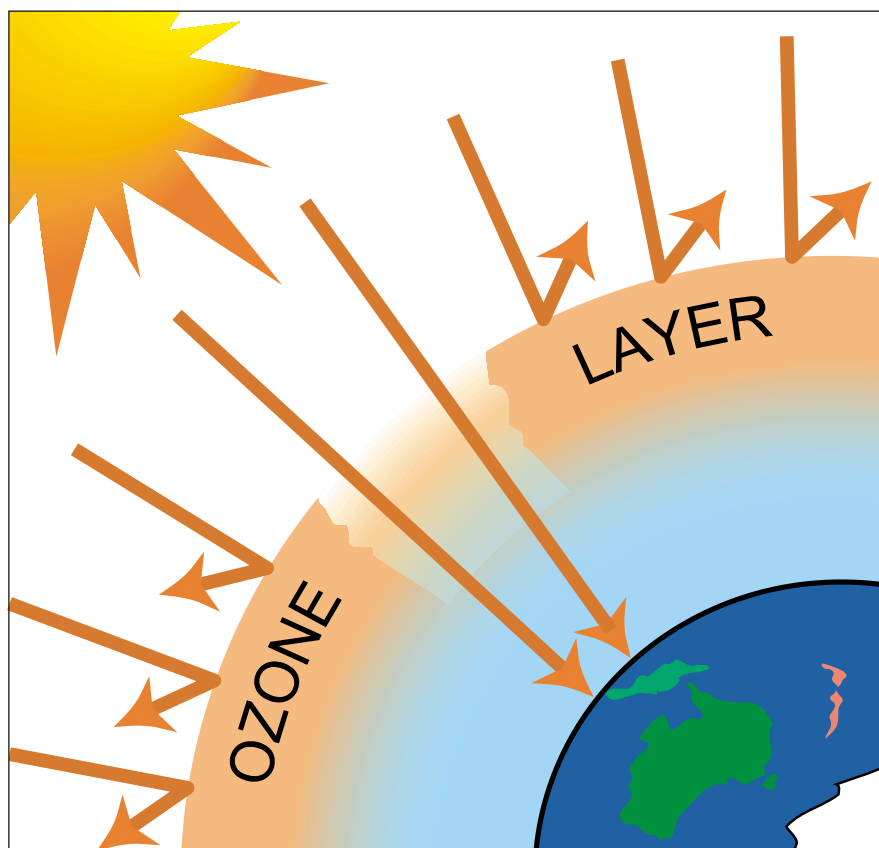

R134a Properties

Since 1993 the Automotive industry of developed countries has started to use a non-ozone-depleting refrigerant HFC 134a (hydrofluorocarbon), its chemical name being Tetra Fluoroethane. We commonly refer to this refrigerant as R134a.

R134a was selected as a replacement refrigerant for R12 (Dichlorodifluoromethane) because R12 containing chlorine has a major effect to ozone layer depletion.

R134a and water have the same abilities to change the state, but R134a can do this more rapidly and at much lower temperature than water. At anytime above -26.3°C , R134a change its state, becoming a vapor and absorb large quantities of heat from inside the vehicle. This is what creates the cooling effect you feel inside the vehicle.

R134a is stored in containers under high pressure. If it is released into the atmosphere, it will boil at -26.3°C .

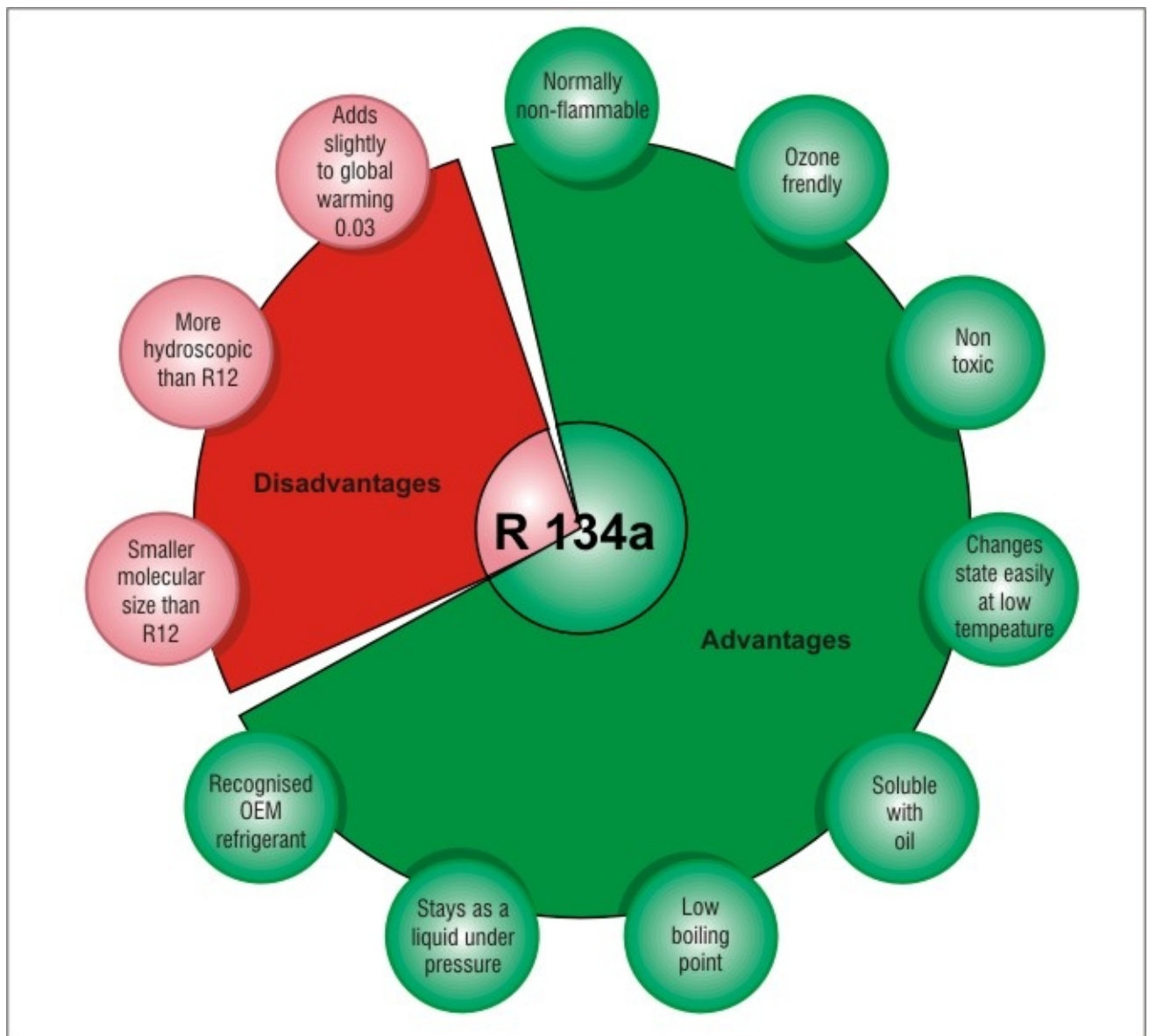

Refrigerant R134a

	R134a (HFC 134a)	R12 (CFC 12)
Chemical name	Tetra Fluoro Etan	Dihlorodifluoro metan
Chemical formula	CH_2FCF_2	CCL_2F_2
Ozone depleting potential (R11=1.0)	0	1.0
Global warming potential	less than 0.3	3.0
Boiling point	-26.3°C	-29.6°C
Chemical structure Molecular strucure	4.2 Angstroms	4.4 Angstroms

R134 - Temperature/Pressure Data					
Temp. °C	Pressure kPa	Temp. °C	Pressure kPa	Temp. °C	Pressure kPa
-46	-64	4	236	30	666
-38	-45	6	260	34	758
-34	-32	8	286	38	858
-30	-17	10	313	42	966
-26	0.3	12	341	46	1083
-22	20	14	371	50	1210
-18	43	16	402	54	1347
-14	69	18	434	58	1494
-10	99	20	469	60	1571
-6	133	22	505	70	2004
-2	171	24	543	80	2520
0	191	26	582	90	3133
2	213	28	623		

R12 Comparasion - Temperature/Pressure Data					
Temp. °C	Pressure kPa	Temp. °C	Pressure kPa	Temp. °C	Pressure kPa
-46	-54	-6	150	30	666
-38	-32	-2	184	38	758
-30	-1	0	207	46	858
-26	11	4	248	50	966
-22	32	8	292	54	1083
-18	56	12	344	56	1210
-14	85	18	432	60	1347
-10	116	26	571		

Principles of Air Conditioning

(Expansion Valve System)

High pressure side

Low pressure R134a vapor entering the compressor is compressed to become high pressure/temperature R134a vapor. This is then circulated along with lubricant oil to the condenser. As the high pressure/temperature vapor travels through the condenser, heat is released to the cooler ambient air passing over the condenser tubes condensing the vapor into a liquid. This high pressure/temperature liquid then travels through the filter drier onto the expansion valve where a small variable orifice provides a restriction against which compressor pushes.

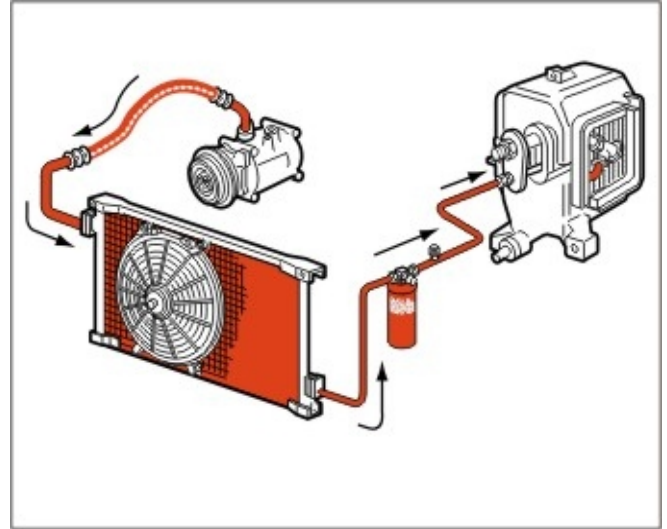

Low pressure side

Suction from the compressor pulls the high pressure/temperature liquid R134a through small variable orifice of the TX valve and into the low-pressure side of the A/C system. The R134a is now under low pressure/temperature vapor where heat from the cabin being blown over the evaporator coil surface is absorbed into the colder low pressure refrigerant. The R134a is then pulled through the evaporator and into the compressor. The A/C cycle begins again as the R134a vapor is compressed and discharged under pressure.

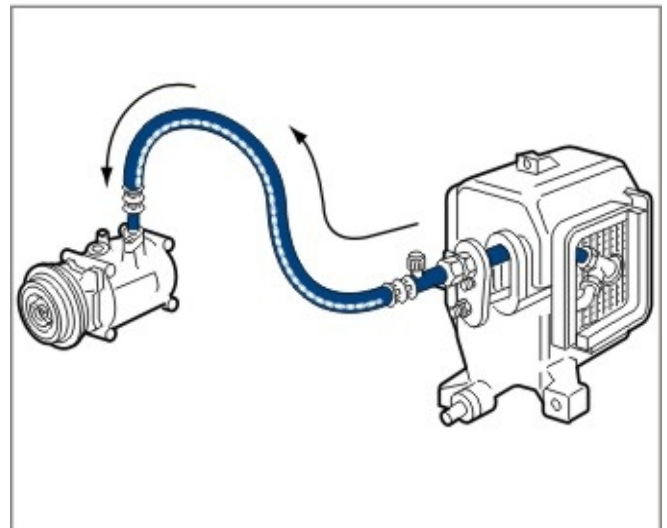

Heat transfer

R134a in the LOW-PRESSURE side is COLD and can absorb large quantities of heat from the air moving over the evaporator.

R134a in HIGH-PRESSURE side is HOT and the cooler ambient air moving over the condenser can absorb the heat from it.

Summary

- When the R134a pressure is **low**, the R134a temperature is **low**.
- When the R134a pressure is **high**, the R134a temperature is **high**.

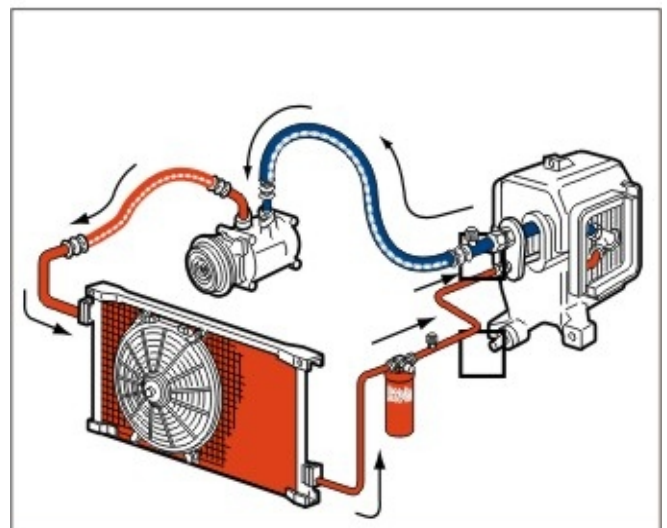

A/C System with: Thermal Expansion Block Valve, Serpentine Condenser, Serpentine Evaporator

(Note: Temperatures shown are examples only)

Serpentine Evaporator

R134a enters the evaporator coil as a cold low-pressure liquid. As this liquid passes through the evaporator coil, heat moves from the warm air blowing across the evaporator fins into cooler refrigerant. This air that has now been cooled is then ducted into the cabin via the blower motor.

Thermal expansion block valve

Small variable orifice provides a restriction against which compressor pushes.

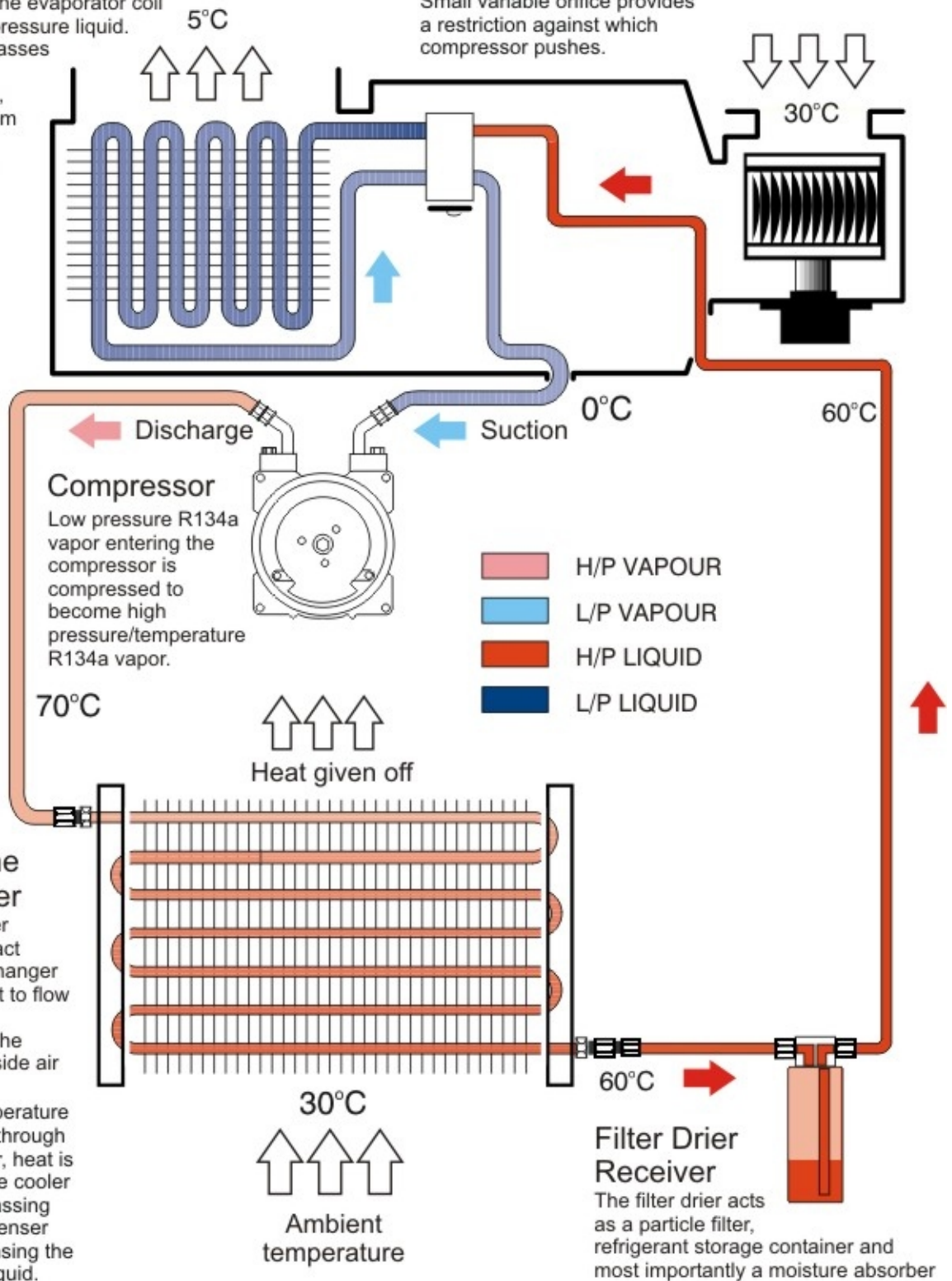

Serpentine Condenser

The condenser function is to act as a heat exchanger and allow heat to flow from the HOT refrigerant to the COOLER outside air. As the high pressure/temperature vapor travels through the condenser, heat is released to the cooler ambient air passing over the condenser tubes condensing the vapor into a liquid.

Filter Drier Receiver

The filter drier acts as a particle filter, refrigerant storage container and most importantly a moisture absorber

A/C System with: Expansion Valve, Parallel Flow Condenser, Plate and Fin Evaporator

(Note: Temperatures shown are examples only)

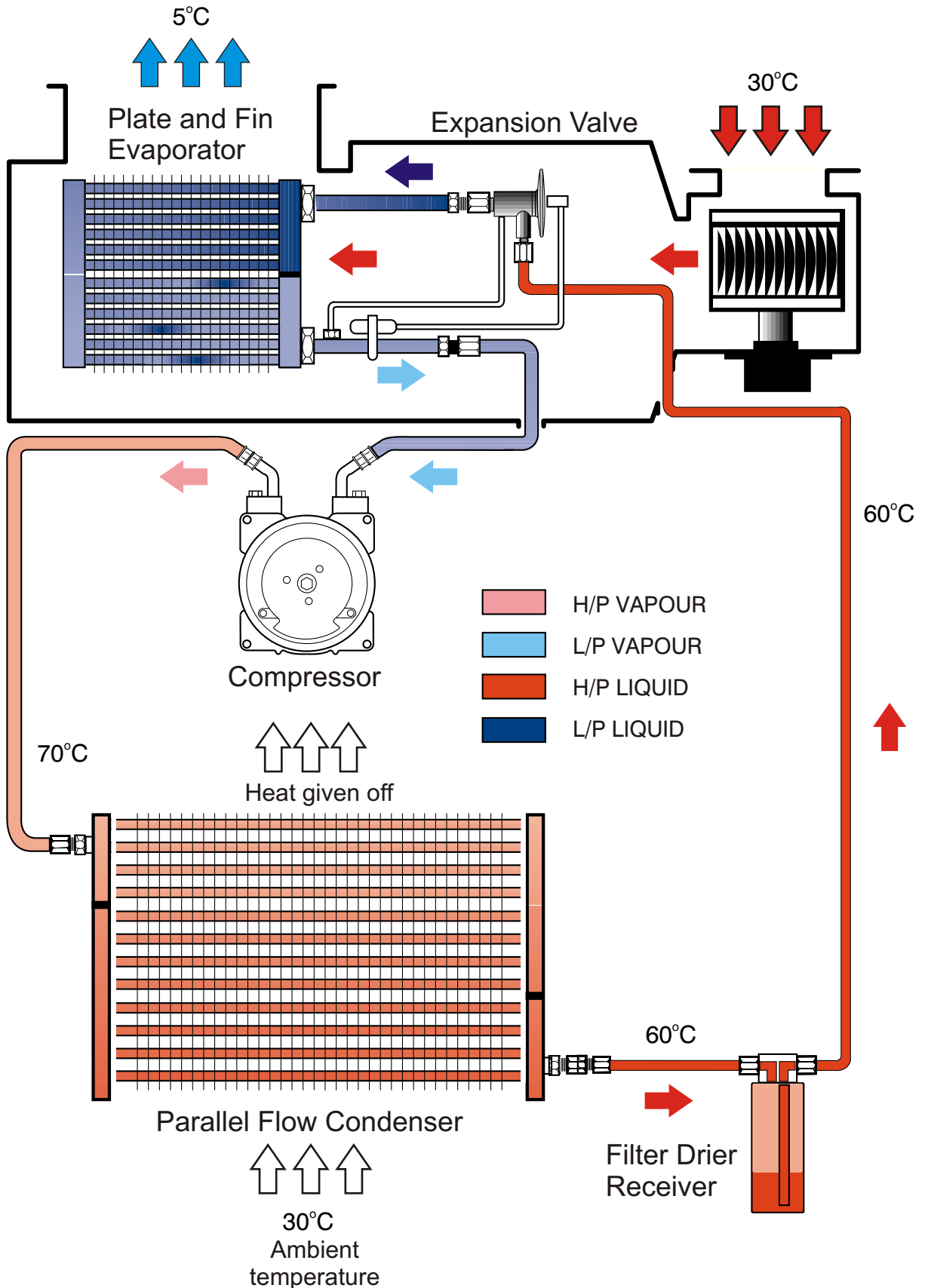

**A/C System with: Orifice Tube, Accumulator, Parallel Flow Condenser
Plate and Fin Evaporator**

(Note: Temperatures shown are examples only)

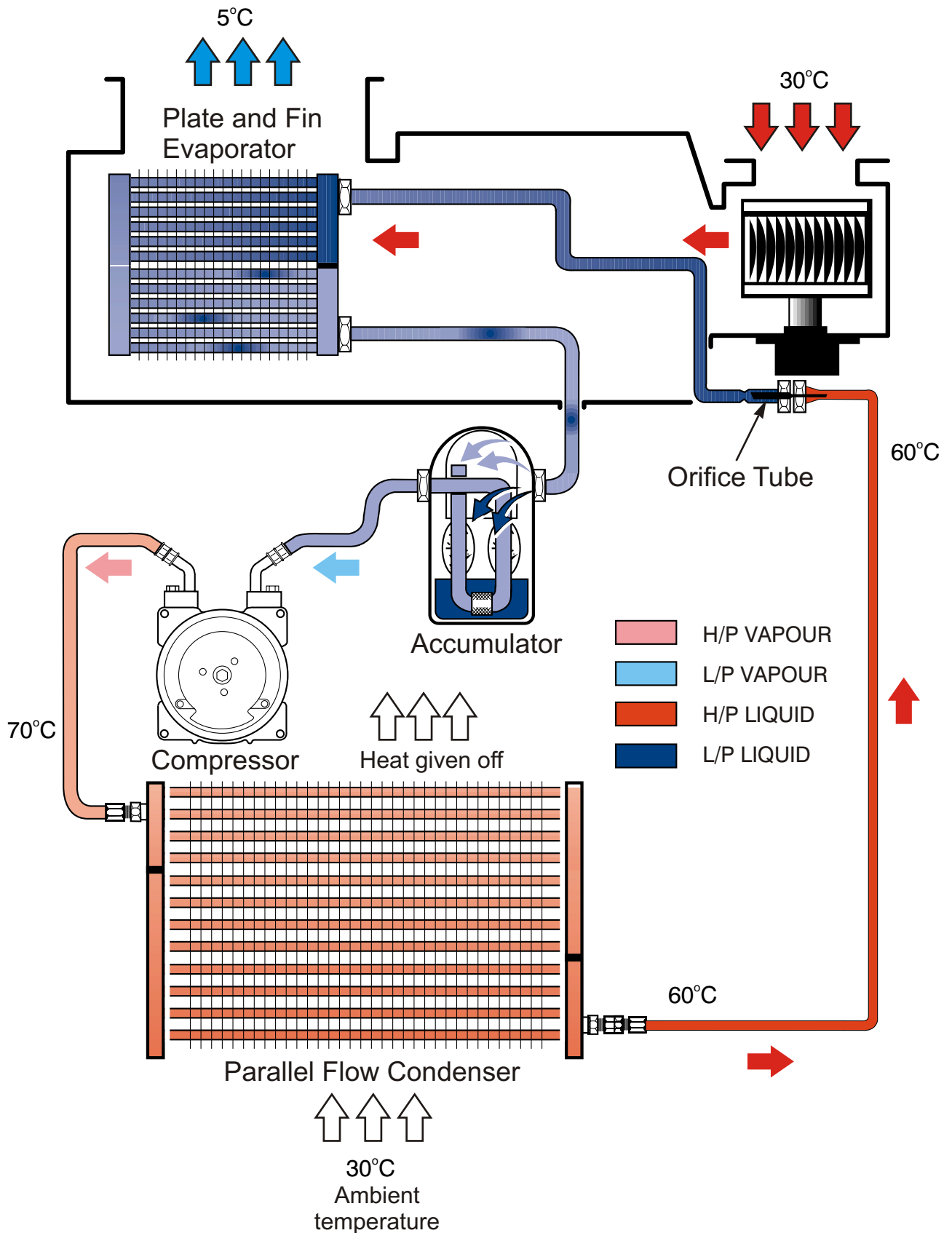

**Dual A/C System with: Externally Equalized Expansion Valves (x2),
Serpentine Condensers in series (x2),
Serpentine Evaporator in parallel (x2),
Electrical Refrigerant Flow Shut Off Valves.**

(Note: Temperatures shown are examples only)

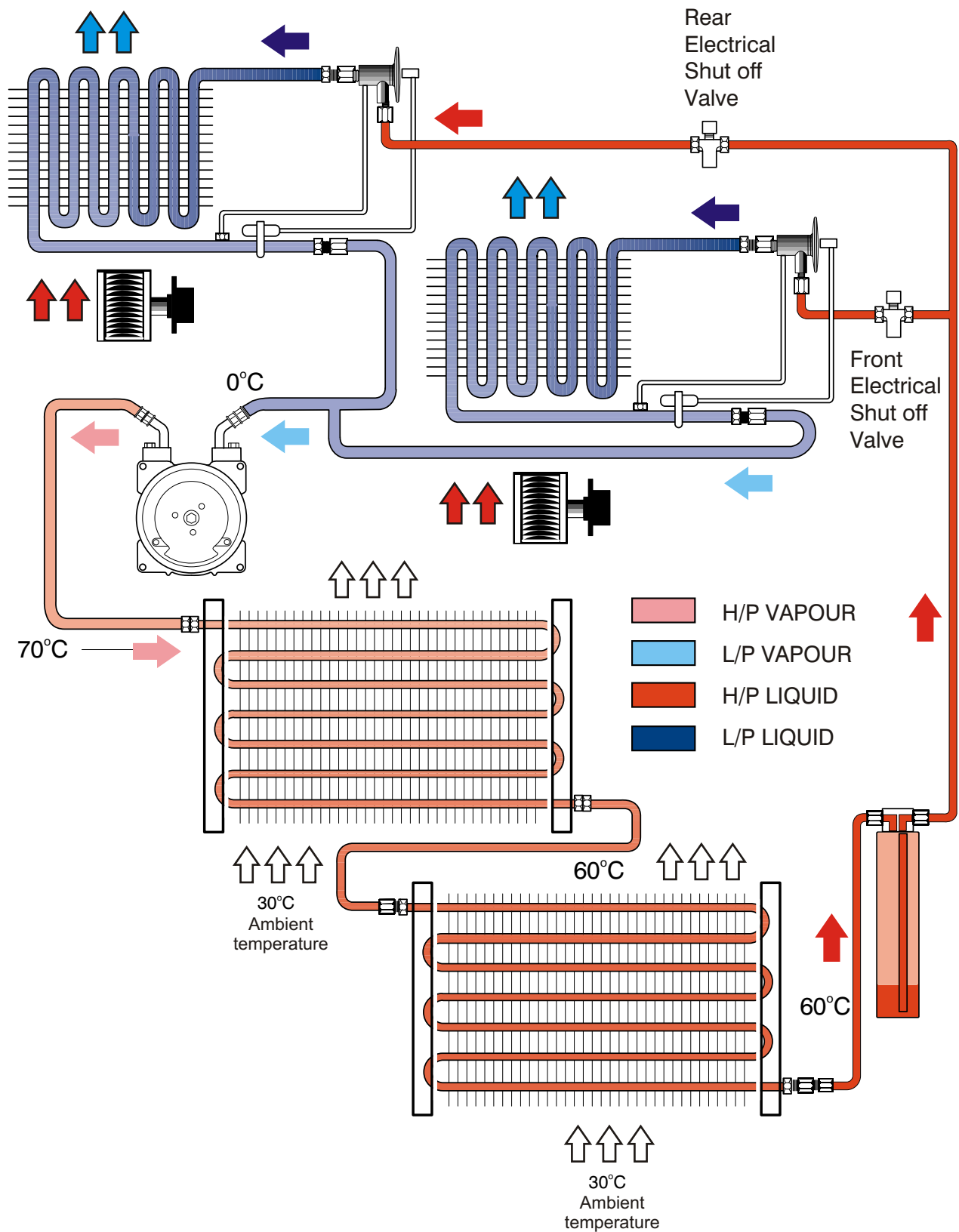

Compressors

General

There are various makes and types of compressors used in automotive air conditioning systems operating on R134a. The internal design could be Piston, Scroll, Wobble plate, Variable stroke or Vane. Regardless, all operate as the pump in the A/C system to keep the R134a and lubricating oil circulating, and to increase the refrigerant pressure and thus temperature.

Sanden - Wobble plate

A reciprocating piston, fixed displacement compressor. The pistons are operated by a wobble plate, which moves them backwards and forwards in the cylinders. As the front shaft turns the wobble plate angle changes, causing the pistons to move in and out, pulling refrigerant vapor in through the suction side, compressing it and discharging this high pressure vapor into the condenser.

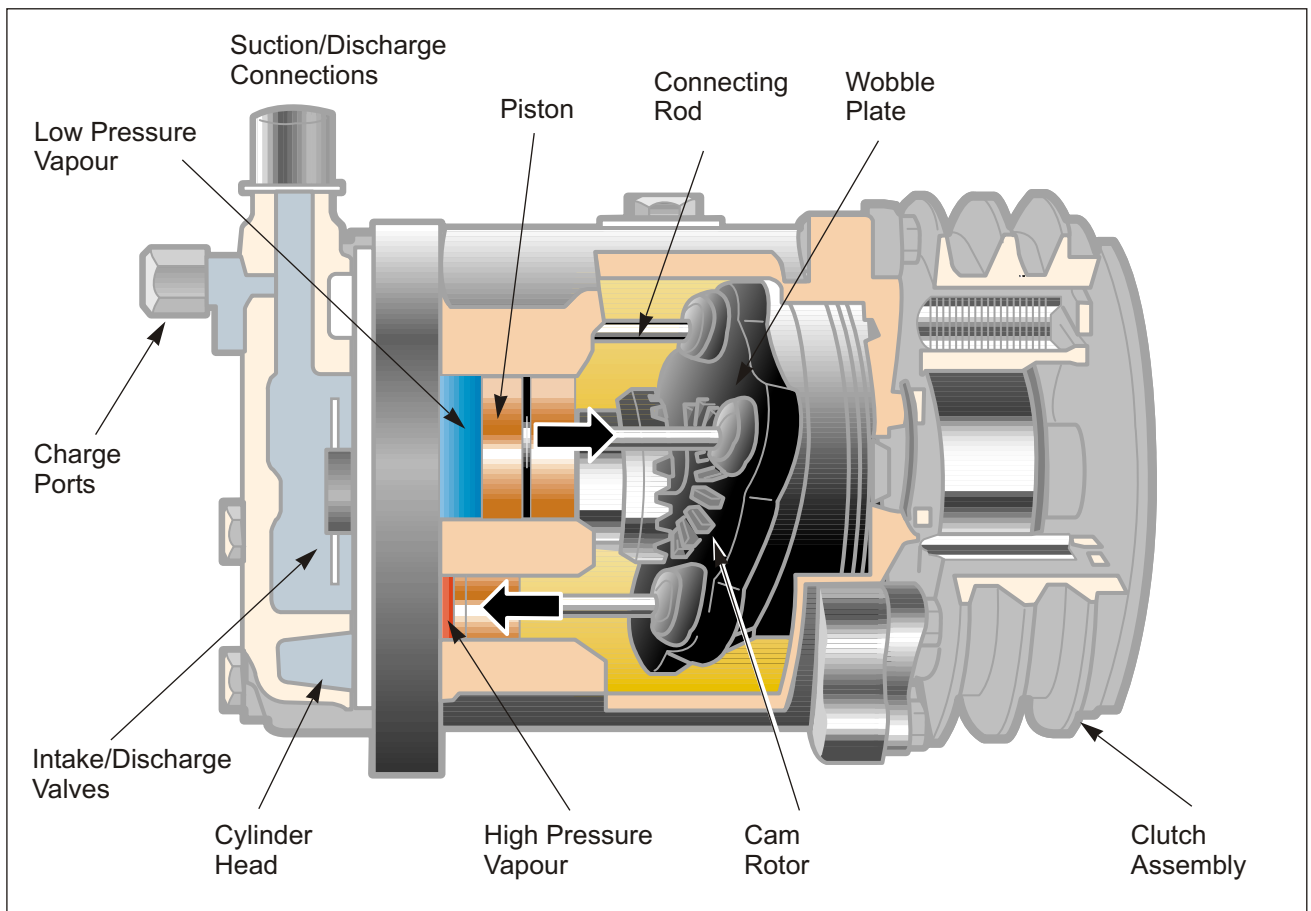

Compressors

Scroll type - Sanden

This compressor uses a unique design with two scrolls, one fixed and one is movable, both are inter-leaved. The movable spiral is able to ORBIT or oscillate without actually fully rotating. The movable scroll is connected to the input shaft via a concentric bearing. As the movable spiral oscillates within the fixed spiral, a number of pockets are formed between the spiral. As these pockets decrease in size the refrigerant is squeezed, the pressure increases and is discharged through a reed valve at the discharge port in the rear section of the compressor.

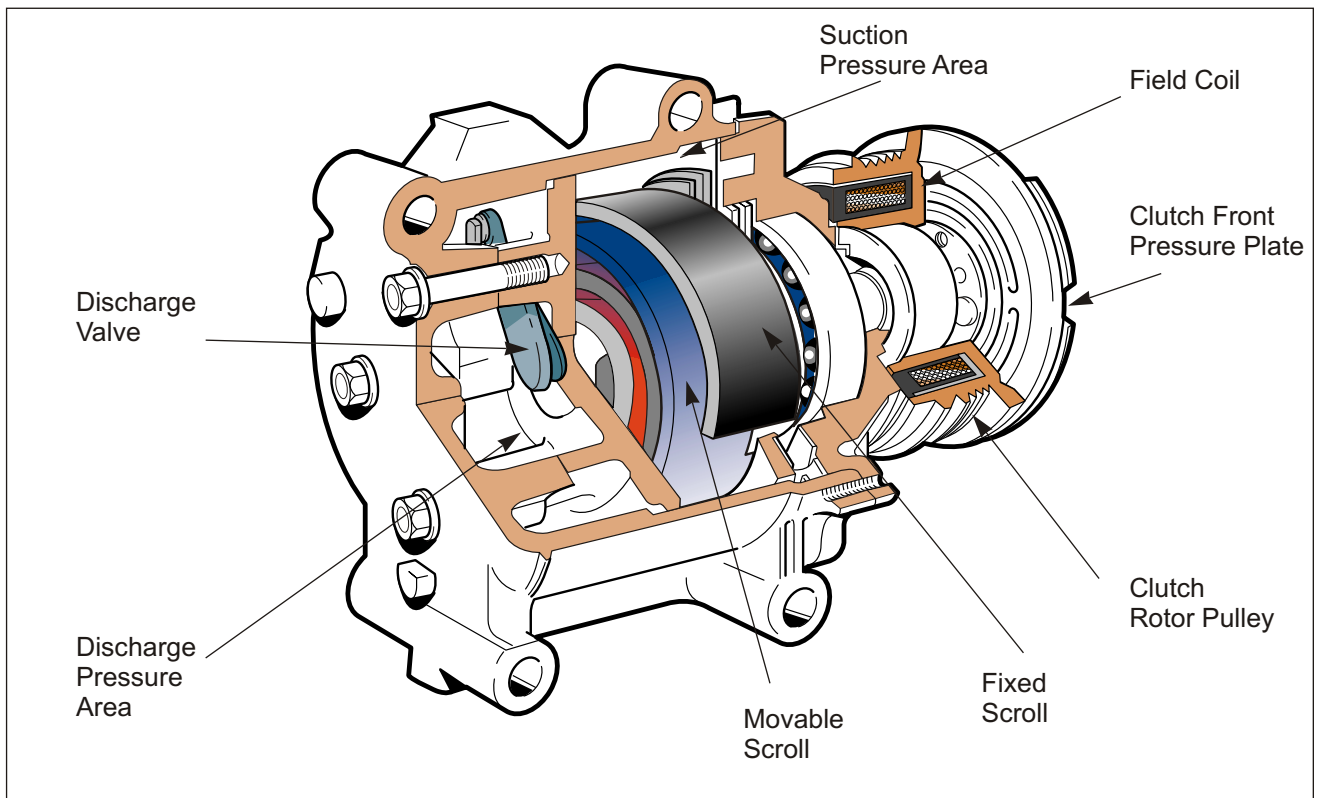

Compression Cycle

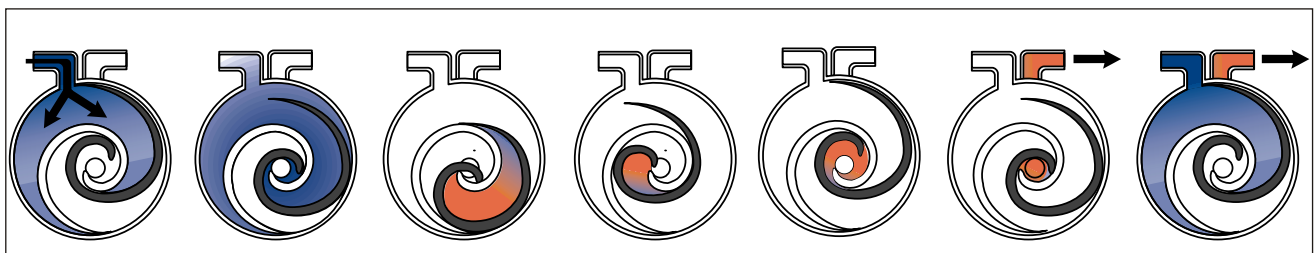

Compressors

Variable stroke - Harrison V5

The Delphi (Harrison) V5 compressor is a non-cycling variable displacement compressor. The compressor varies displacement to control capacity to meet A/C system demand at all operating conditions. The compressor features a variable angle wobble plate in five (V5) cylinder axial piston design.

Displacement is controlled by a bellows actuated control valve located in the rear cylinder head. This control valve senses and responds to the system suction pressure or A/C system demand. Through regulation of compressor crankcase pressure, the wobble plate angle, and therefore compressor displacement is variable.

In general, the compressor discharge pressure is much greater than the compressor crankcase. Which is greater than or equal to the compressor suction pressure. **At maximum displacement**, compressor crankcase pressure is equal to the compressor suction pressure. **At reduced or minimum displacement**, the compressor crankcase pressure is greater than the suction pressure.

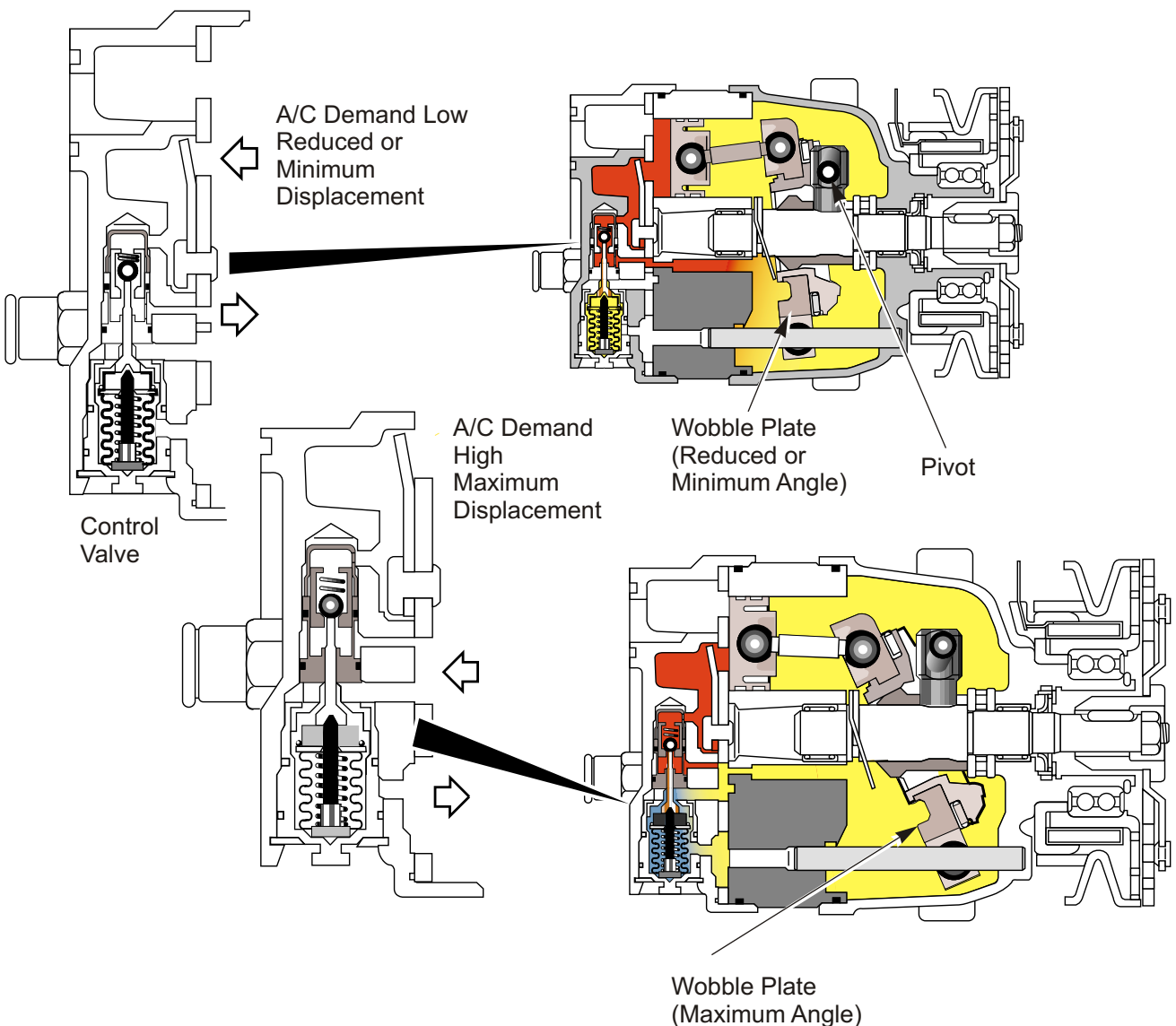

Compressors

Rotary Vane - Panasonic

Rotary vane compressors consist of a rotor with three or four vanes and a carefully shaped rotor housing. As the compressor shaft rotates, the vanes and housing form chambers.

The R134a is drawn through the suction port into these chambers, which become smaller as the rotor turns. The discharge port is located at the point where the gas is fully compressed.

The vanes are sealed against the rotor housing by centrifugal force and lubricating oil. The oil sump and oil pump are located on the discharge side, so that the high pressure forces oil through the oil pump and then onto the base of the vanes keeping them sealed against the rotor housing.

During idle an occasional vane noise from the compressor may be heard. This is due to the time taken for lubricating oil to circulate through the A/C system.

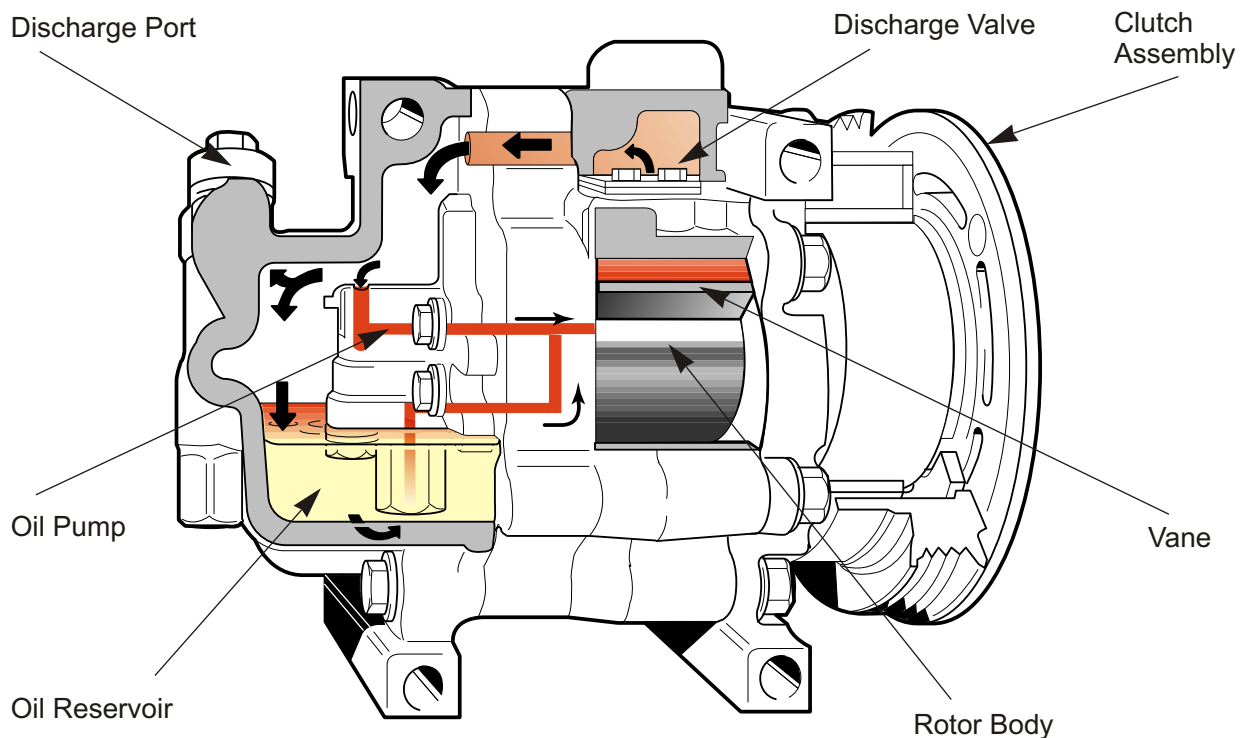

Compressors and Mount & Drive

Mount & Drive

Consists of a bracket to mount the compressor to the engine, a belt idler pulley, compressor drive belt and possibly an extra drive pulley for the crankshaft.

Compressor Mount

Manufactured of either plate, cast iron, steel or aluminium, this bracket should exhibit excellent noise absorption qualities especially if using a piston type compressor.

Idler Pulley

A small pulley normally used in conjunction with a belt adjusting mechanism, also used when a belt has a long distance between pulleys to absorb belt vibrations.

Drive Pulley

Some vehicles do not have an extra pulley to accommodate an A/C drive belt, in these cases an extra pulley is bolted onto the existing crankshaft pulley.

Multiple Belt Drive

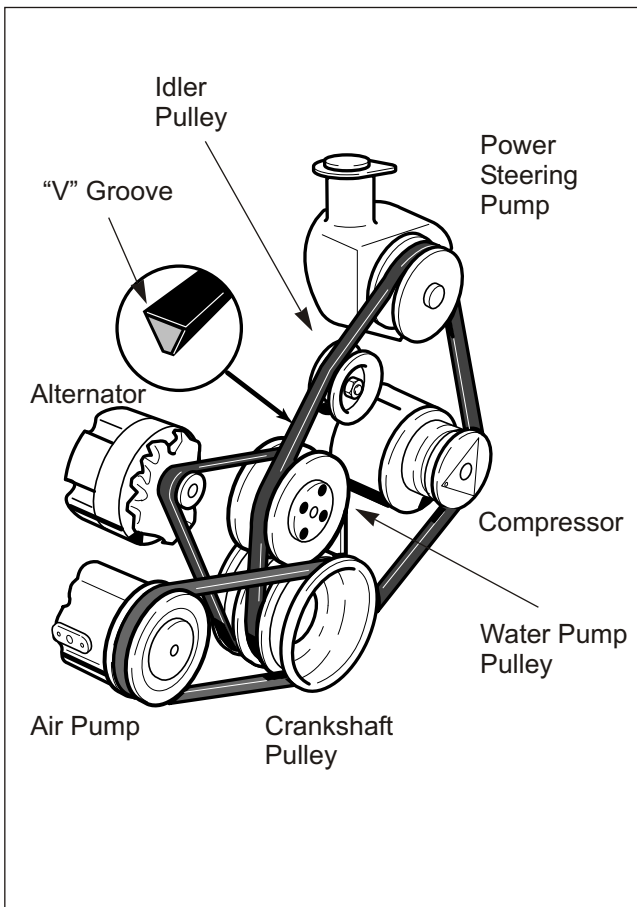

Serpentine Belt Drive

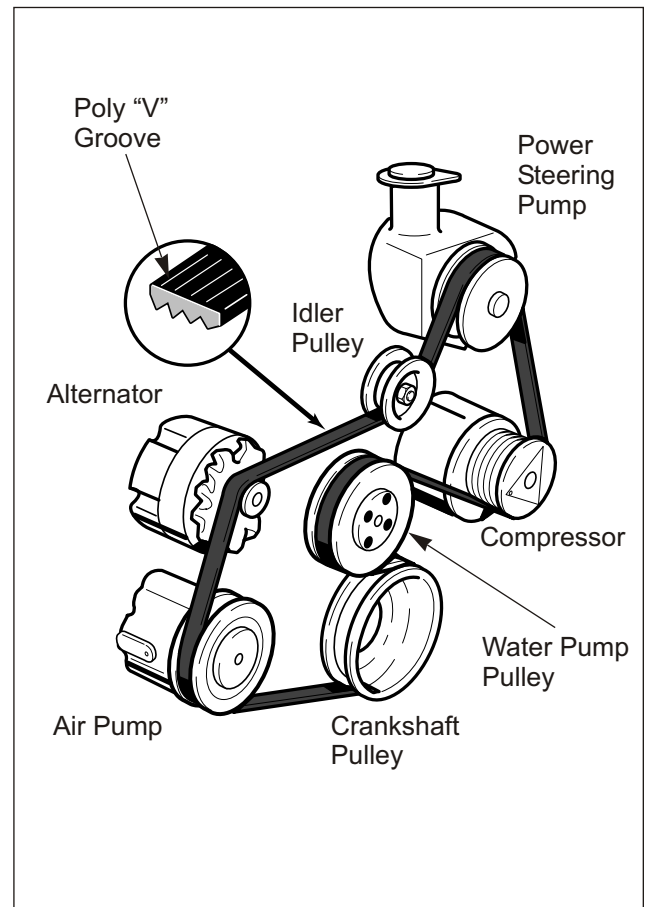

Clutches

Compressor Clutch

The clutch is designed to connect the rotor pulley to the compressor input shaft when the field coil is energized. The clutch is used to transmit the power from the engine crankshaft to the compressor by means of a drive belt.

When the clutch is not engaged the compressor shaft does not rotate and refrigerant does not circulate the rotor pulley free wheels. The field coil is actually an electromagnet, once energized it draws the pressure plate towards it, locking the rotor pulley and the pressure plate together causing the compressor internals to turn, creating pressure and circulating refrigerant.

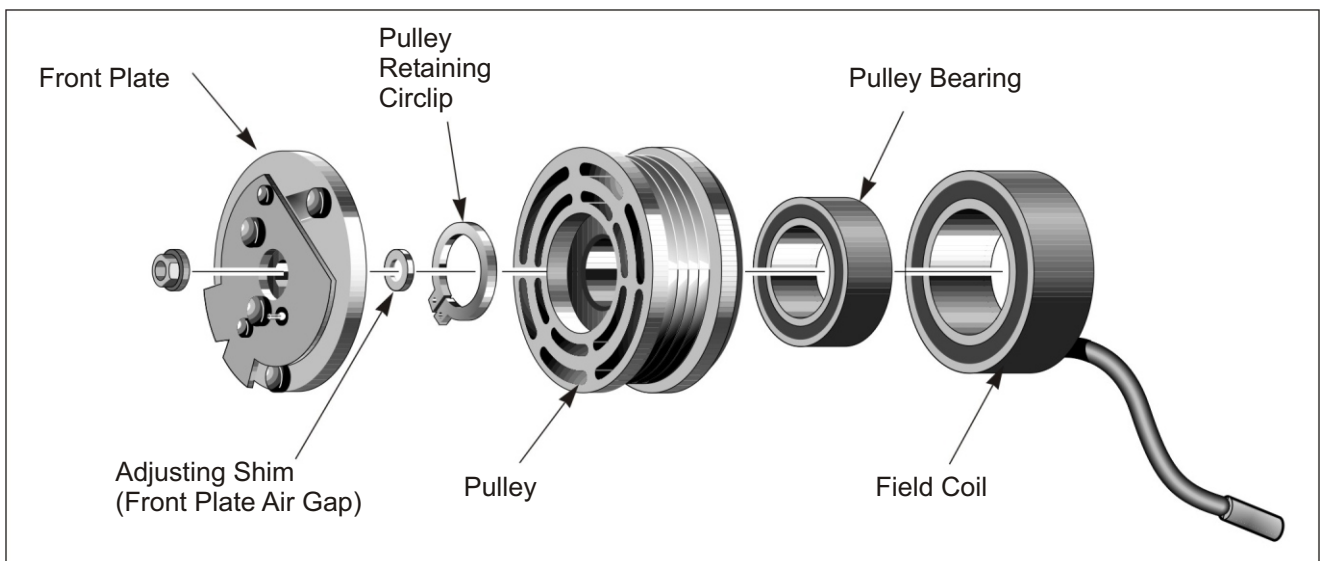

Lubrication

R134a is part of the air conditioners lubrication system. NEVER operate an A/C system without refrigerant as there will be no lubrication for the compressor and internal damage will occur.

Refrigerant oil is circulated around the A/C system saturated in the refrigerant.

Ariazone recommends PAOil as best automotive compressor lubricant.

PAOil is a Polyalpha Olefin, Not a PAG or an Ester. This is a fully synthetic oil, carefully blended to be a superior oil. It is so good that it can be used in all automotive compressors, whatever the brand. It's a non-aggressive, safe oil that won't effect seals or hoses and is compatible with other lubricants. And it's non-hygroscopic.



www.rocoil.com

PAOil	PAG oil	POLYOLESTER oil	MINERAL oil
NON Hygroscopic	Hygroscopic	Hygroscopic	Hygroscopic
COMPATIBLE with other lubricants	NON COMPATIBLE with other lubricants	NON COMPATIBLE with other lubricants	NON COMPATIBLE with other lubricants
COMPATIBLE with: HCFC's CFC's HFC's HFC BLENDS HCFC BLENDS	NOT COMPATIBLE NOT COMPATIBLE COMPATIBLE COMPATIBLE NOT COMPATIBLE	COMPATIBLE COMPATIBLE COMPATIBLE COMPATIBLE	COMPATIBLE COMPATIBLE NOT COMPATIBLE NOT COMPATIBLE
LOW MISCIBILITY PREVENTS OIL LOGGING	MISCIBLE MAY NOT PREVENT OIL LOGGING	MISCIBLE MAY NOT PREVENT OIL LOGGING	MISCIBLE MAY NOT PREVENT OIL LOGGING
INCREASES CAPACITIES GIVING SHORTER RUN TIMES FOR THE SAME LOAD	UNLIKELY TO INCREASE CAPACITIES	UNLIKELY TO INCREASE CAPACITIES	UNLIKELY TO INCREASE CAPACITIES
SUPERIOR HIGH TEMPERATURE VISCOSITY PROPERTIES	FAIR HIGH TEMPERATURE VISCOSITY PROPERTIES	FAIR HIGH TEMPERATURE VISCOSITY PROPERTIES	POOR HIGH TEMPERATURE VISCOSITY PROPERTIES
NON AGGRESSIVE A TOTALLY SAFE PRODUCT	AGGRESSIVE	AGGRESSIVE	NON AGGRESSIVE

Precautions when using PAG oil:

- Do not allow PAG oil to contact bare skin or vehicle paintwork.
- Flush skin immediately when using PAG oil.
- Avoid breathing PAG oil/R135a mixture.
- PAG oil is highly hygroscopic. Open containers only when ready to use. Cap container immediately after use.

Condensers

The Condenser function is to act as a heat exchanger and allow heat to flow from the hot refrigerant to the cooler outside air.

R134a entering the condenser will be a high-pressure high temperature vapor. As the R134a vapor travels through the tubes of the condenser heat is given off to the cooler ambient air; the refrigerant vapor condenses and changes to a liquid state.

At this point a large amount of heat is given off by the R134a. The refrigerant will now be a hot, high pressure liquid.

Design types

Serpentine

This type of condenser consists of one long tube which is coiled over and back on itself with cooling fins in between the tubes.

Parallel flow design (Recommended for R134a)

This design is very similar to a cross flow radiator. Instead of refrigerant travelling through one passage (like serpentine type), it can now travel across numerous passages. This will give larger surface area for the cooler ambient air to contact.

Serpentine Flow

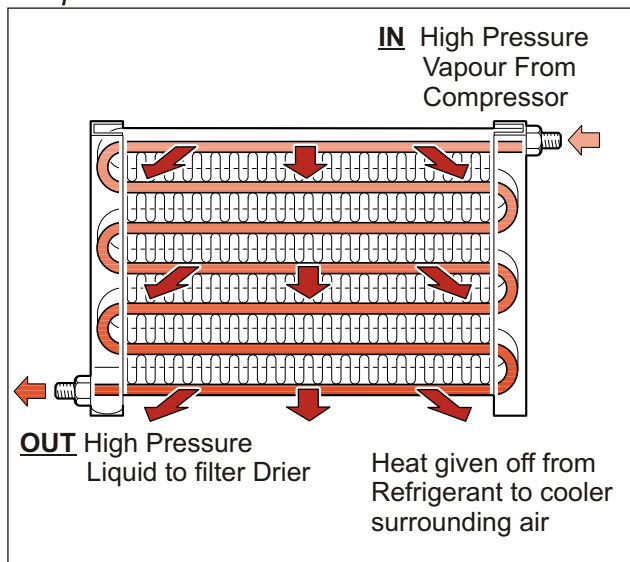

Parallel Flow

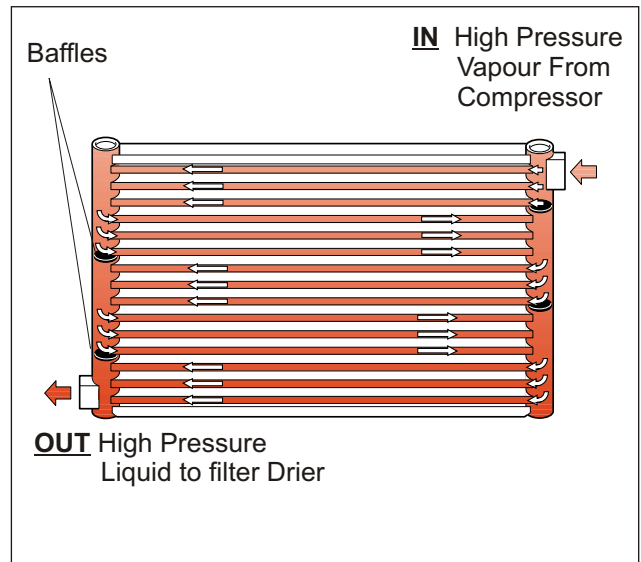

R134a - R12 Comparison

- As R134a operates on higher pressures, less internal flow, restrictive and improved heat rejection condensers are required.
- Most manufacturers select the parallel flow design for this version. They are approximately 25% more efficient than the serpentine condensers.

Foam Seals

Foam seals

These seals are fitted in between the condenser and radiator to prevent the heated ambient air exiting above, below or to the sides of the space in between (normally 25mm) the radiator and condenser.

As ambient air is drawn through condenser by the condenser or radiator fan, its temperature increases. If gaps are present between the condenser and radiator this heated air can be circulated back through the condenser. This results in the increased condenser temperature and causes reduction in the performances of the A/C system.

Without Foam Seals

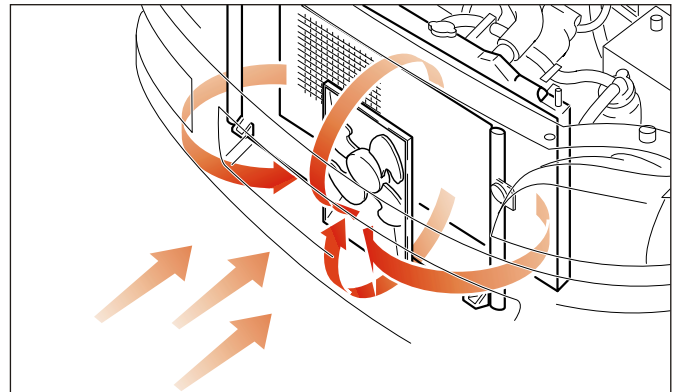

Condenser electric fan

Most vehicles with air conditioning require an electric fan to assist air flow, either pushing or pulling the air through the condenser, depending on which side of the condenser the fan is placed.

The majority of vehicles using R134a require this additional condenser cooling due to the higher operating pressures of R134a. Also most modern vehicles now have smaller grilles or bumper bar openings. This causes poor air flow conditions especially by the amount of air flow over the condenser.

The condenser fan is operated with A/C engaged in various ways:

- Medium pressure switch;
- Indirect connection to the compressor clutch
- Via the Electronic Control Module (ECM);
- Signal from the A/C switch activation.

Fan Types

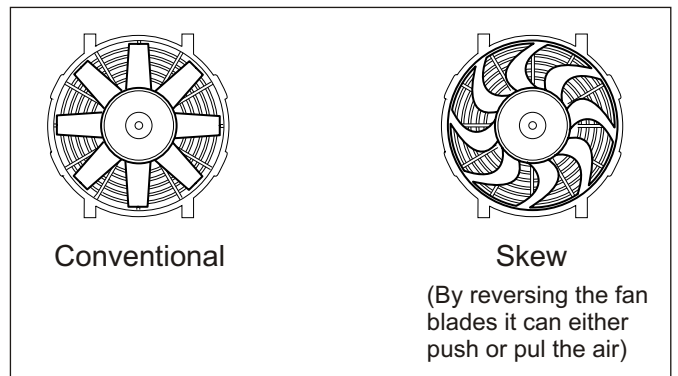

Basic Circuit

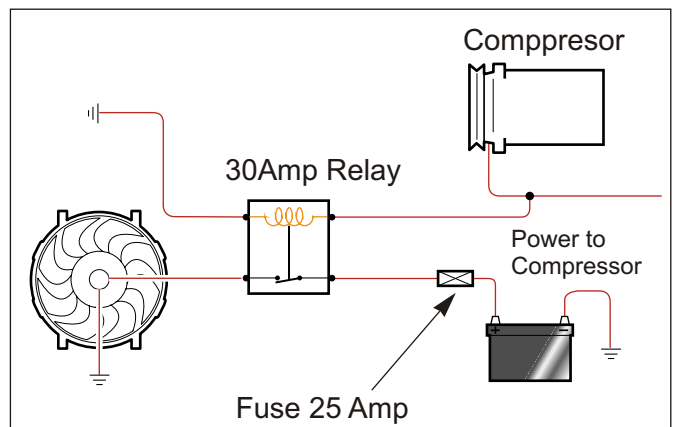

R134a - R12 Comparison

Increased use (operation time) with R134a systems due to higher refrigerant temperature.

Foam Seals

R134a enters the evaporator coil as a cold low-pressure liquid. As this liquid passes through the evaporator coil, heat moves from the warm air blowing across the evaporator fins into cooler refrigerant. This air that has now been cooled is then ducted into the cabin via the blower motor.

When there is enough heat to cause a change of state, a large amount of the heat moves from the air to the refrigerant. This causes the refrigerant to change from a low-pressure cold liquid into a cold vapor. (Latent heat of evaporation).

As the warmer air blows across the evaporator fins, moisture contained in that air (humidity) will condense on the cooler evaporator fins. Condensed moisture then runs off through the drain tubes located at the underside of the evaporator case.

Serpentine evaporator

Same design as the serpentine condenser but approximately five times deeper.

Serpentine evaporator

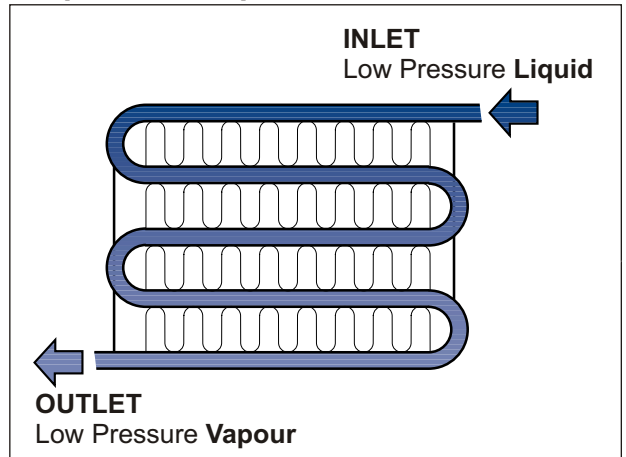
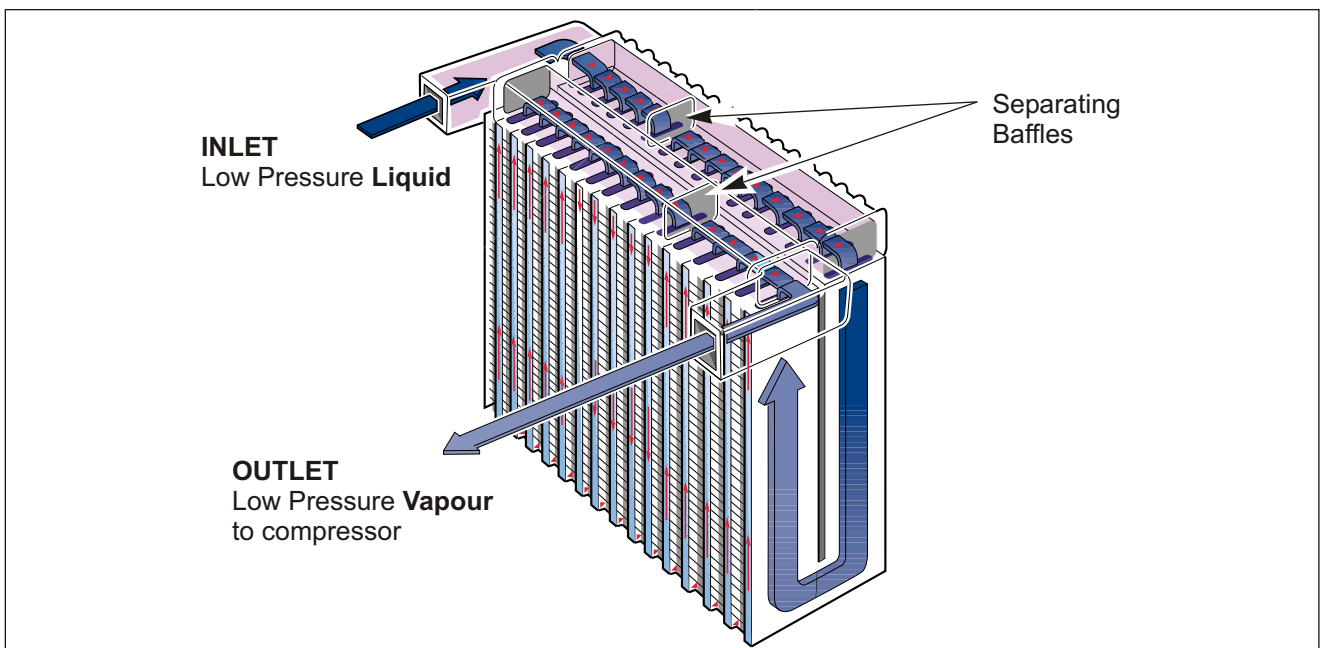

Plate & Fin Laminated Evaporators

Similar operation to the parallel flow condenser were the refrigerant has a multi flow pass creating a large surface area.

Plate & Fin Laminated Evaporator (Recommended for R134a)



R134a - R12 Comparison

Most manufacturers prefer to use the plate and fin design for R134a because of 20% performance increase over the serpentine design.

Thermal Expansion Valves

Refrigerant flow to the evaporator must be controlled to obtain maximum cooling, while ensuring that complete evaporation of the liquid refrigerant takes place. This is accomplished by the thermal expansion valve (TXV).

Pressures in control

As shown in the illustration, the TXV controls the refrigerant flow by using a system of opposing pressures which will call:

F1 - Temperature sensing capillary tube
Sealed tube filled with refrigerant. This refrigerant is also filled above the diaphragm (7). The capillary tube sensing bulb (3) is attached to the evaporator outlet tube surface.

F2 - Pressure compensation tube
This is a hollow tube connected to the evaporator outlet tube and senses the pressure of the R134a refrigerant leaving the evaporator coil. (Other TX valves may not use this tube as pressure is provided internally within the valve).

F3 - Pressure spring
This spring (6) is located under the ball valve (5).

Operation

Open

When the evaporator outlet tube temperature increases, the refrigerant (3) in the capillary tube **expands**, forcing the diaphragm (7) downwards and thus pushing pin (A) also downwards causing the ball valve (5) to move away from the metering orifice (4), allowing more R134a to enter the evaporator inlet side.

Closed

As the evaporator outlet tube becomes cooler, the refrigerant in the capillary tube (3) **contracts**. Forces F2 and F3 cause the diaphragm (7) and pin (A) to move upward allowing the ball valve to move towards the metering orifice (4), restricting the R134a flow. The outlet tube gets warmer and the process starts over.

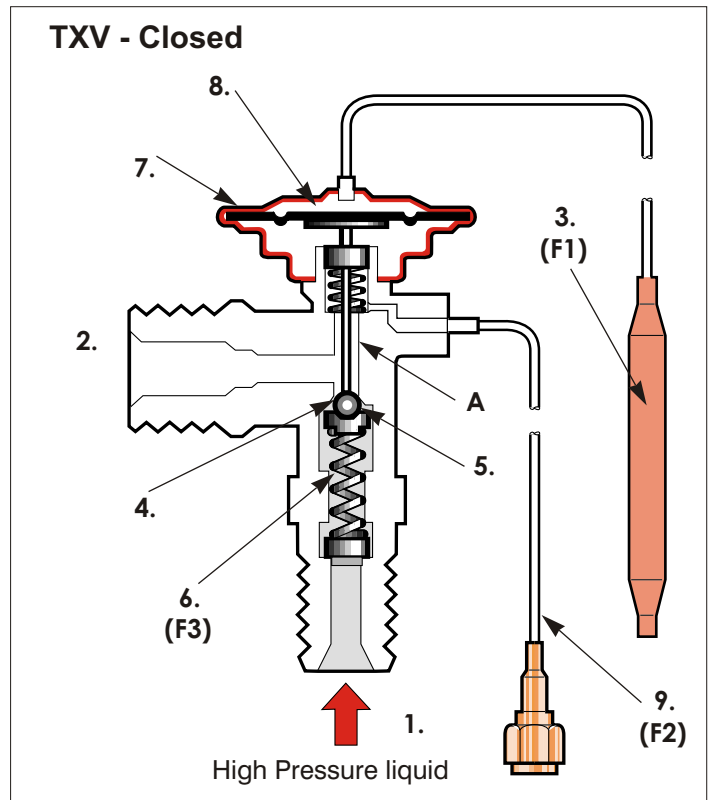

- | | |
|------------------------|-------------------------------|
| 1. From Filter Drier | 6. Spring |
| 2. To Evaporator Inlet | 7. Diaphragm |
| 3. Capillary tube | 8. Refrigerant |
| 4. Metering Orifice | 9. Pressure Compensating Tube |
| 5. Ball valve | |

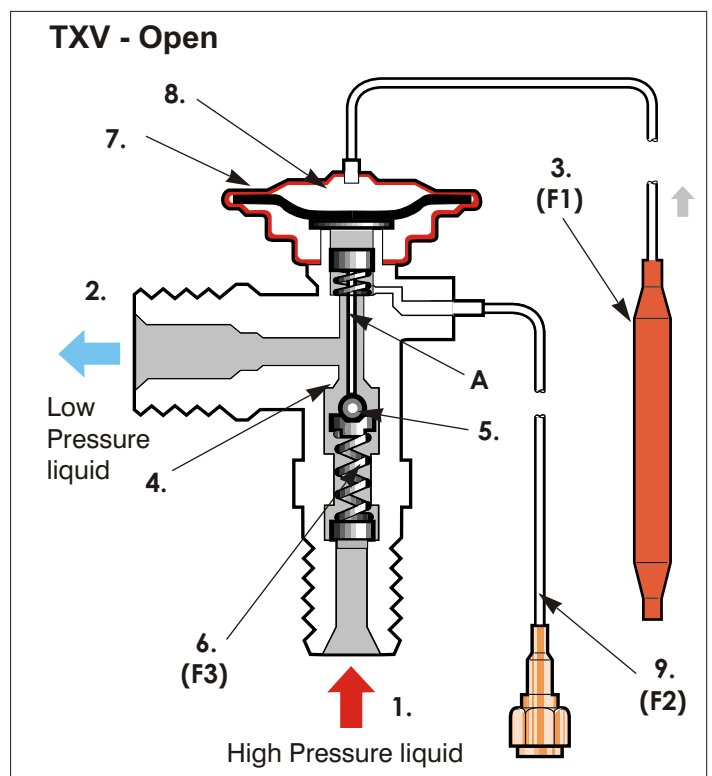

Thermal Expansion Block Valve

The block valve differs from the previously mentioned expansion valve in that it has four passages, although the basic operation is exactly the same. Operation of the block valve is still via refrigerant expansion/contraction within a diaphragm (11), but not sensed through separate tube (capillary tube). It is sensed by changes in the refrigerant temperature and pressure passing from the evaporator outlet through the block valve.

As the refrigerant from the outlet side of the evaporator passes over the sensing element (12), expansion or contraction of the refrigerant takes place causing the activating pin (8) to move the ball valve (6) away or closer to the metering orifice. This allows more or less refrigerant to enter the evaporator coil inlet.

Pressures in control

As shown in the illustration, the block valve controls refrigerant flow by using a system of opposing pressures which we will call:

F1 - Temperature sensing

This is a sealed diaphragm and sensor containing refrigerant. As refrigerant leaving the evaporator coil outlet passes over sensing element (12) the refrigerant (9) above the diaphragm (11) expands moving pin (8) downwards pushing ball valve (6) away from the metering orifice (5).

F2 - Pressure compensation

This is a passage (10) in the block valve outlet side where refrigerant can build up under the diaphragm (11) to act as an opposing pressure to help regulate the amount of refrigerant into the evaporator coil inlet side.

F3 - Pressure spring

This spring (7) is located under the ball valve (6) and acts as an opposing force trying to move the ball valve towards the metering orifice (12) and to reduce refrigerant flow to the evaporator coil inlet.

TXV - Open

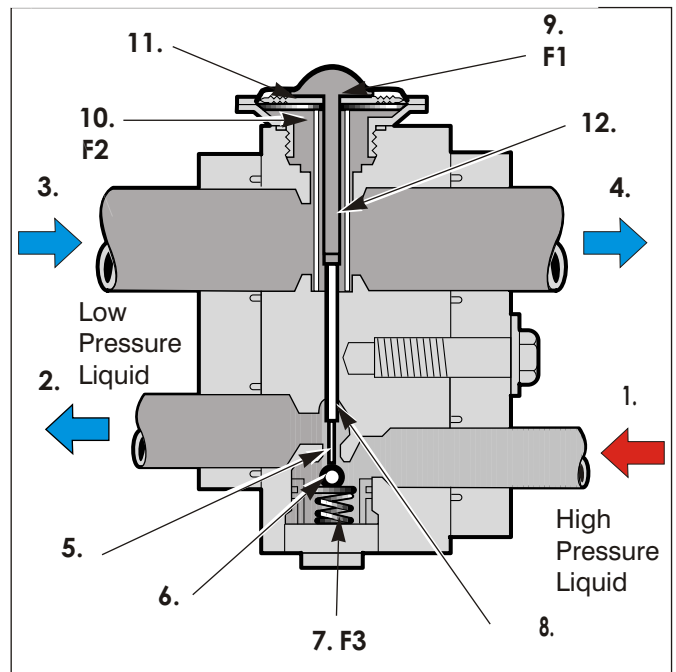

- | | |
|------------------------|---|
| 1. From Filter Drier | 8. Activating Pin |
| 2. To Evaporator Inlet | 9. Refrigerant |
| 3. From Evaporator | 10. Pressure Compensation under Diaphragm |
| 4. To Compressor | 11. Metallic Diaphragm |
| 5. Metering Orifice | 12. Sensing Element |
| 6. Ball | |
| 7. Spring | |

TXV - Closed

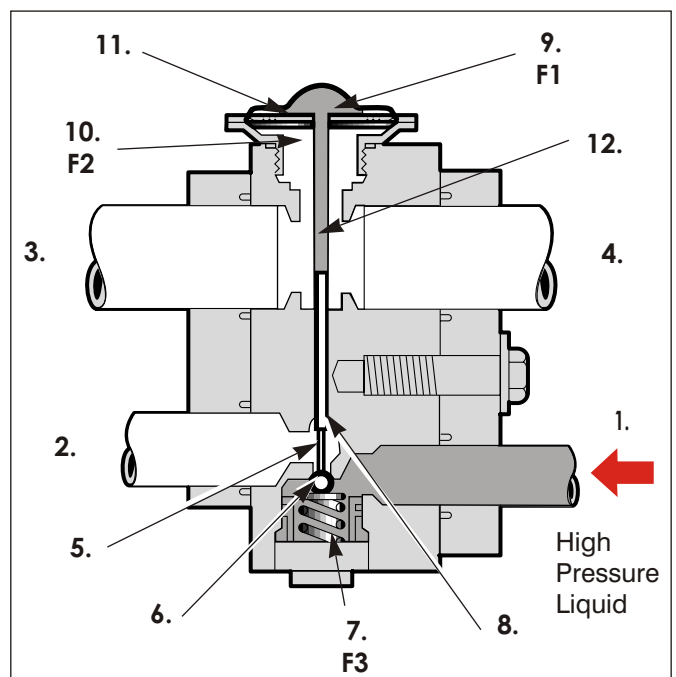

Super Heat

At a certain point in the evaporator the R134a refrigerant is completely vaporized, after that point any additional heat absorbed by the R134a vapor is described as SUPER HEAT.

The value of this SUPER HEAT is the temperature difference above the point at which R134a liquid changes to a vapor.

The thermal expansion valve (TXV) values are preset at factory to compensate for the super heat. Ensure when a TX valve is replaced it is of the type suited to the A/C system.

Saturation temperature = The temperature at which refrigerant in liquid form changes to a vapor at a given pressure.

Actual temperature = The temperature of refrigerant at the evaporator outlet.

Example - Calculation for super heat

$$\begin{array}{r}
 \text{Actual temperature} \quad - \quad 10^{\circ}\text{C} \\
 \text{minus} \\
 \text{Saturated temperature} \quad - \quad 5^{\circ}\text{C} \\
 \hline
 \text{Super heat} \quad = \quad 5^{\circ}\text{C}
 \end{array}$$

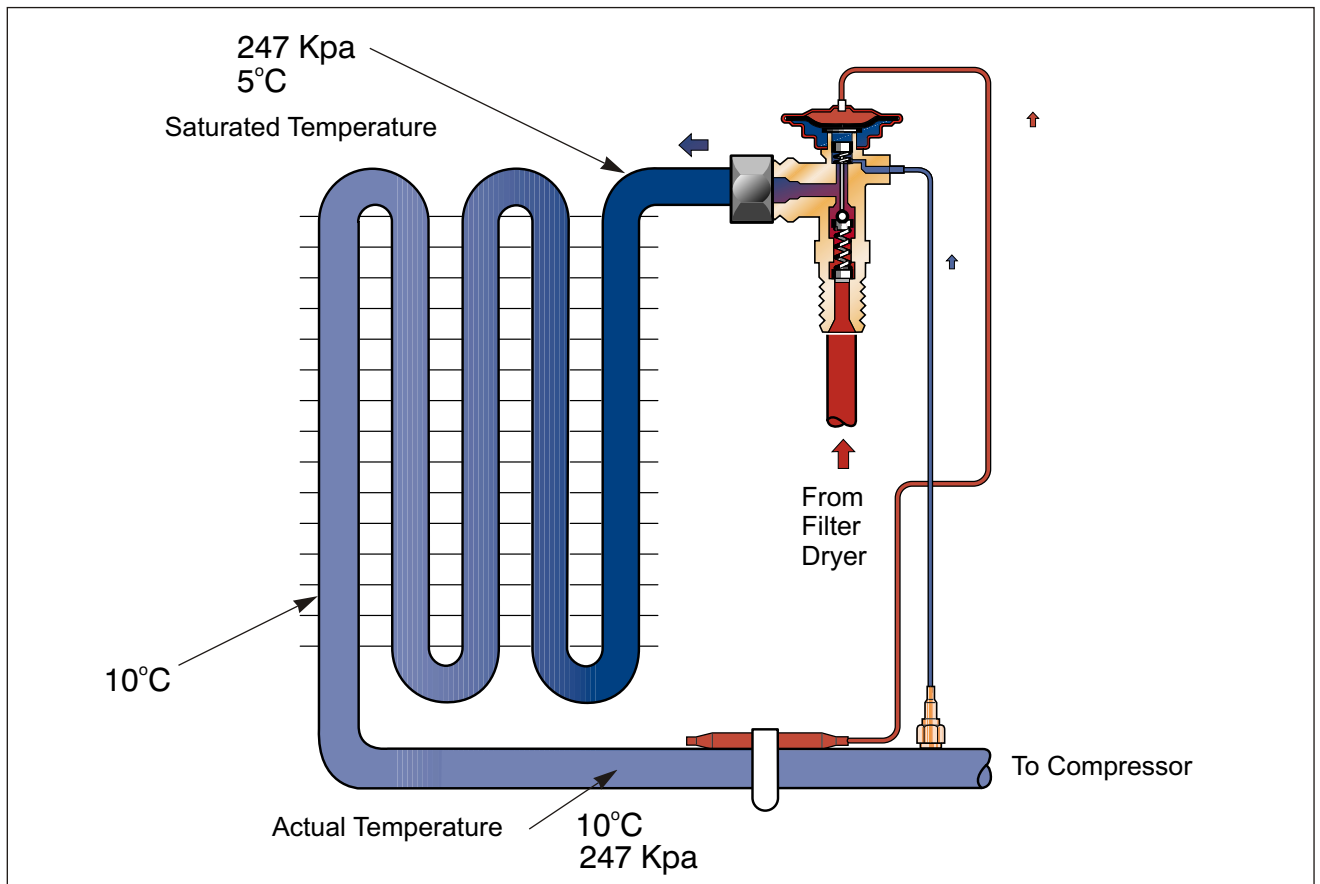

Orifice Tube

At the orifice tube the R134a is forced to flow through a fine restriction (orifice). This causes a pressure drop and temperature drop in the R134a entering the evaporator.

The rate of flow depends on the pressure difference across the restriction.

A fine gauze filter is located at the inlet and outlet sides of the orifice tube to filter any contaminants from passing onto the evaporator.

Orifice tubes have different size restrictions depending on the A/C system; these different sizes can be identified by the outer plastic tube color.

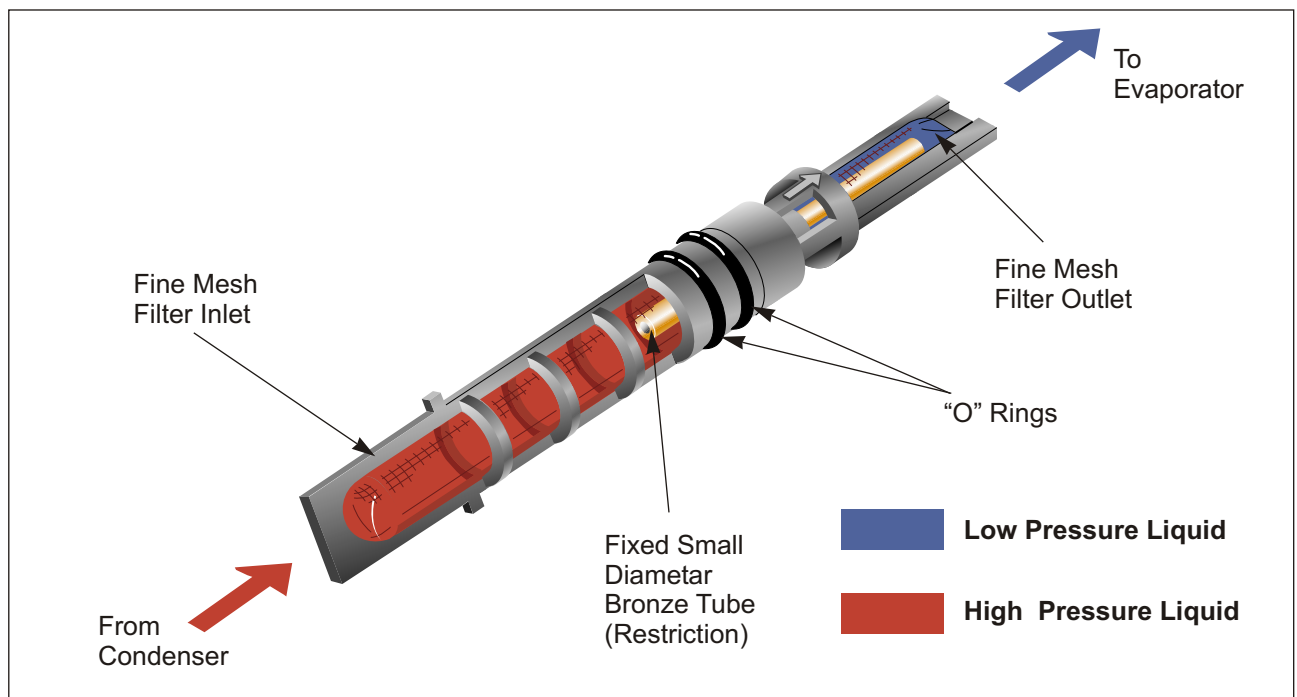

Filter Drier Receiver

The filter drier acts as a particle filter, refrigerant storage container and most importantly moisture absorber.

Moisture, temperature and R134a causes hydrofluoric and hydrochloric acid. The silica gel beads (desiccant) located in the FDR absorb small quantities of moisture thus preventing acid establishment.

Most R134a filter dryers have NO sight glass. This is because at approximately 70°C refrigerant temperature the PAG oil will foam giving a false impression of low gas charge. If the FDR does utilize a sight glass ensure correct diagnosis when viewing.

Note: Ensure the connection indicated with the word "IN" is connected to the condenser outlet.

Important: Never use an R12 FDR on a R134a system.

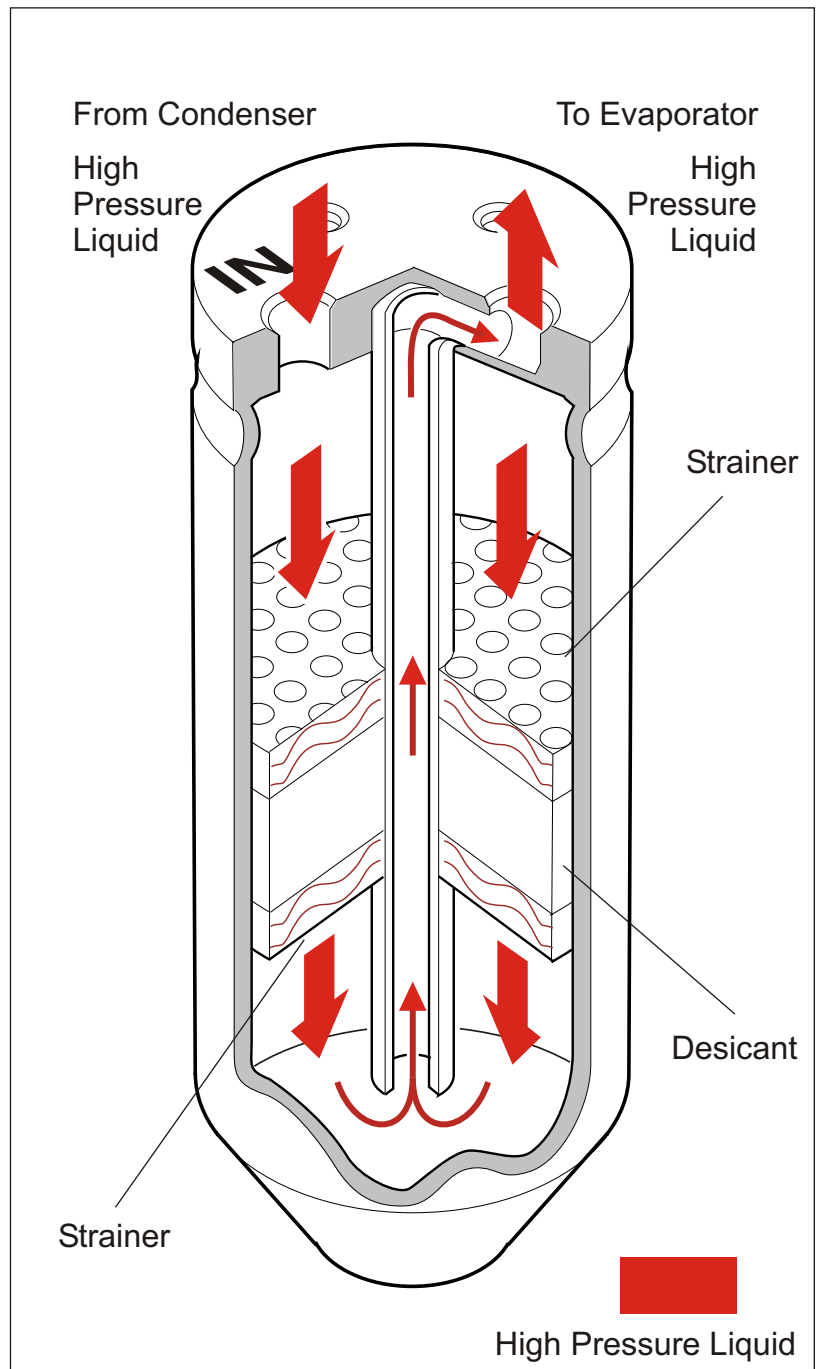

Accumulator (Orifice Tube System)

The function of the accumulator is to store refrigerant, filter particles, absorb moisture and separate vaporous R134a from liquid R134a.

The normal process of the Orifice Tube system works when R134a leaves the evaporator coil as a mixture of vapor and liquid. This liquid enters the accumulator and falls to the bottom. The vapor rises to the top and continues onto compressor. The liquid R134a in the bottom of the accumulator gradually vaporizes off. This vapor rises, then pulls into the compressor.

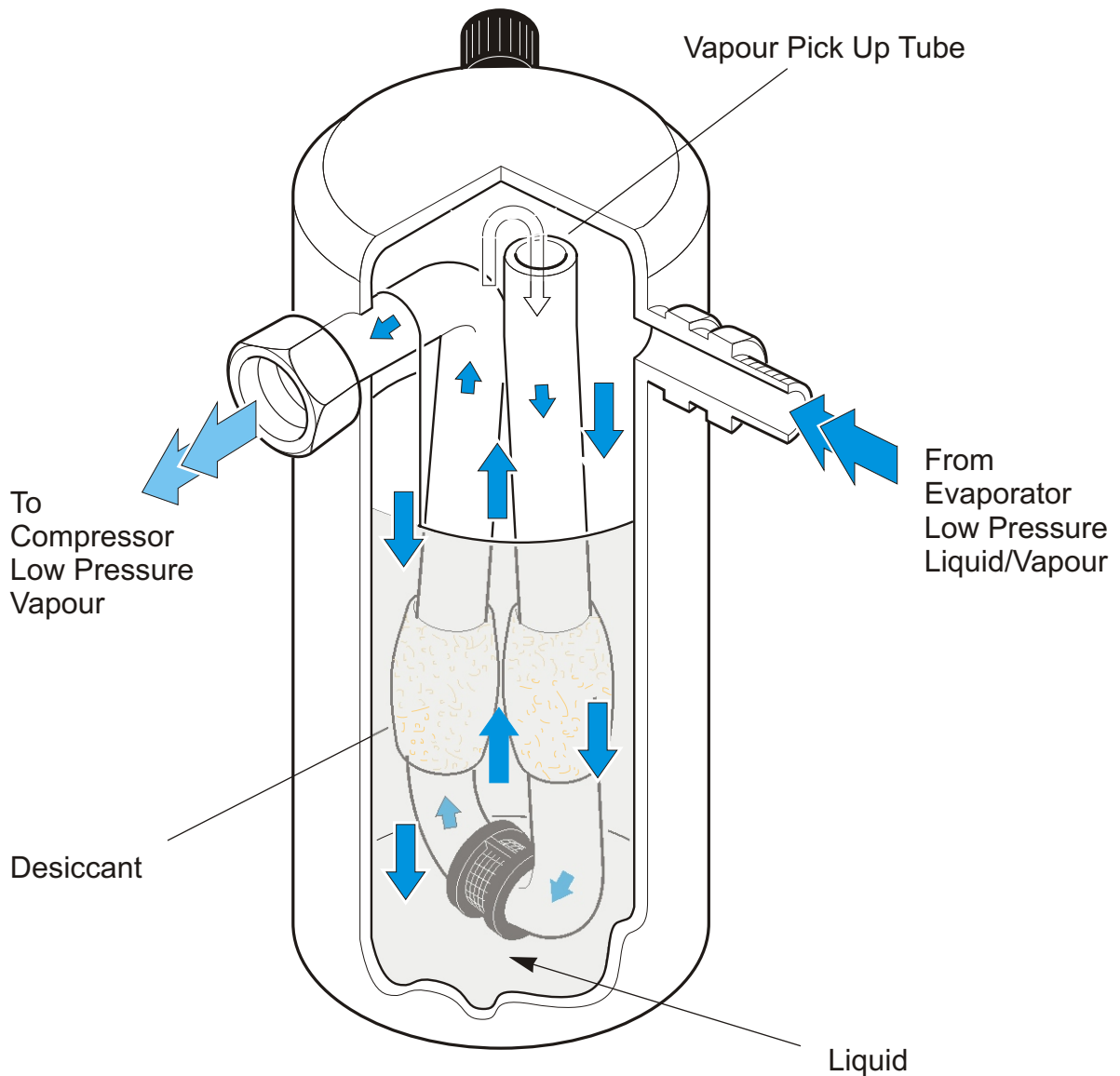

"O" Rings

The "O" ring rubber compound used for R134a A/C system joints, fittings and components is a hydrogenated nitrile butadiene rubber (HNBR) and identified by the color green.

"O" ring lubrication can be carried out using mineral oil. All hoses tubes and components included in an A/C kit are pre-lubricated, as are the "O" rings supplied as a spare part. Other manufacturers could use "O" rings of a different color and size. Ensure that only the approved "O" ring is used for the type of system being serviced or repaired.

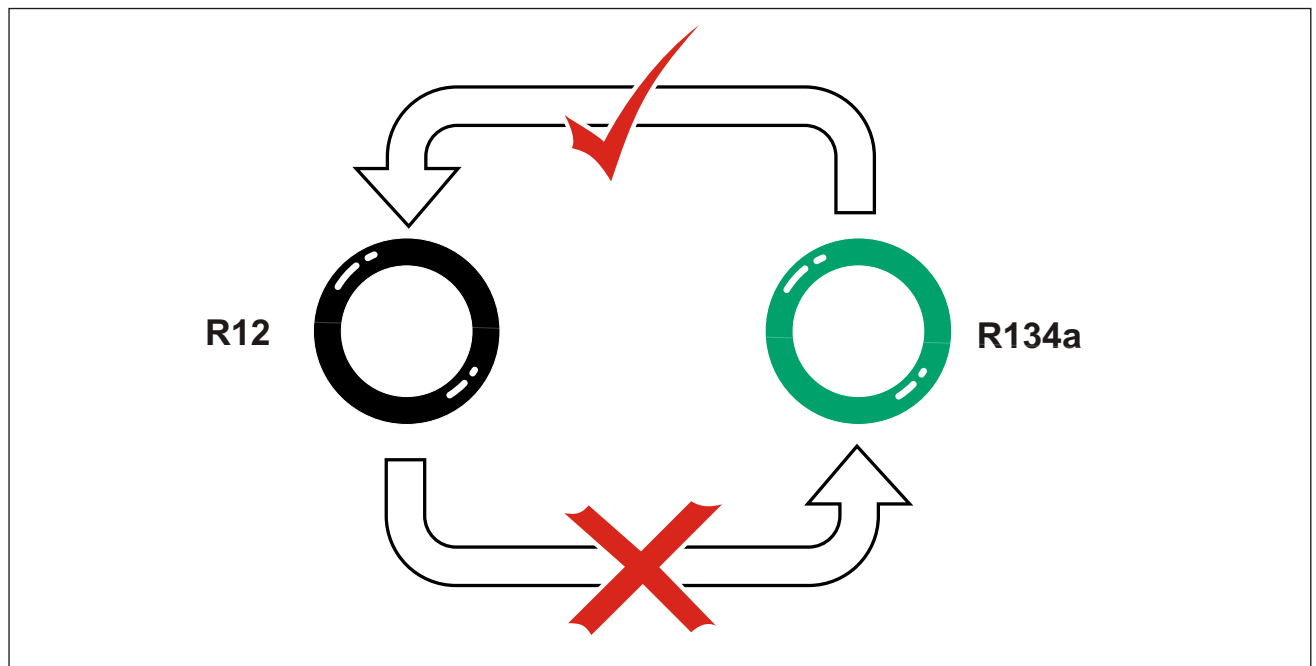

R134a - R12 Comparison

- R12 "O" rings coloured black
- NEVER use R12 "O" rings with R134a as the "O" ring will be damaged owing to the lack of chlorine in R134a
- You can use R134a "O" rings in an R12 system

Hoses

OWING TO THE SMALLER MOLECULAR SIZE AND HIGHER OPERATING PRESSURES OF R134a, the refrigerant hose now incorporates a nylon inner lining. This is to reduce the normal refrigerant leakage that would naturally occur through the porosity of rubber hoses.

Most R134a hoses have a smaller outside diameter and thinner hose walls to improve flexibility and reduce noise levels within the A/C system.

R12

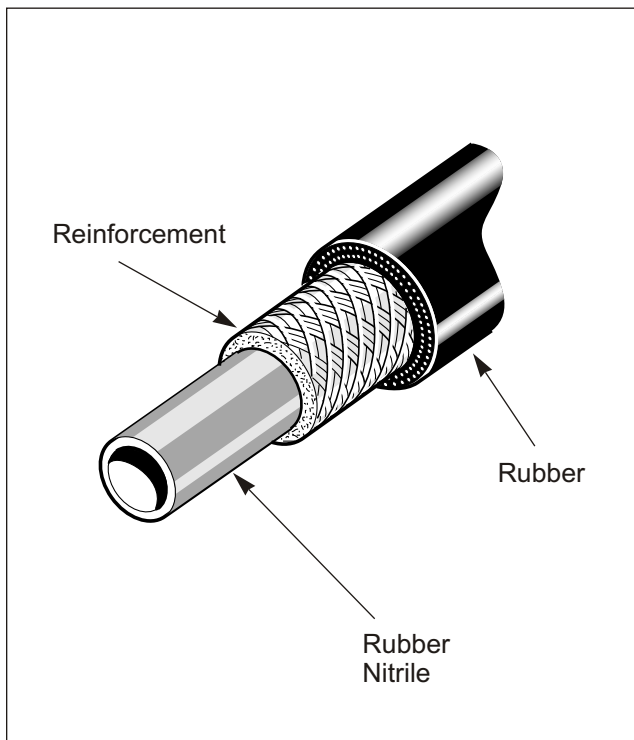

R134a

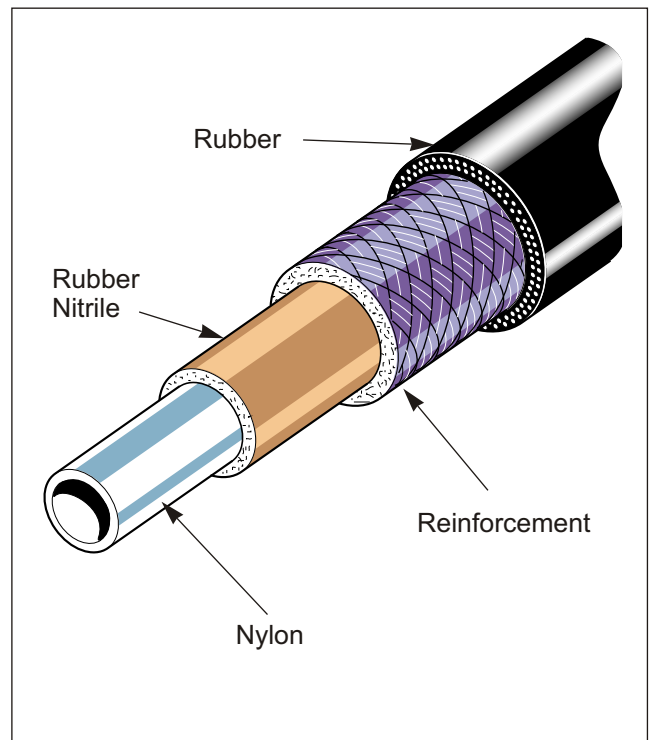

R134a - R12 Comparison

- NEVER use new R12 hose (unless of a barrier type) in an R134a A/C system. The PAG oil and hydrogen contained in the R134a causes the normal R12 nitrile hoses to rapidly deteriorate.
- R12 hoses have normally large outside diameters. This could create higher noise levels,

Charging Ports

Charging ports are fitted onto components such as hoses, tubes and filter dryers receivers.

These charge ports enable the A/C system to be serviced and tested whilst under pressure. Different size ports identify the high and low sides of the A/C system. A plastic cap with rubber seal is used to close the charge port opening and avoid leaking.

A dedicated design of charging valve has also been developed to suit the R134a charging ports.

Most schrader valves will leak slightly. Ensure that the plastic protection cap is fitted. Schrader valves designed for R134a must only be used in R134a systems. This is because of the seal material used.

R134a Quick Coupler

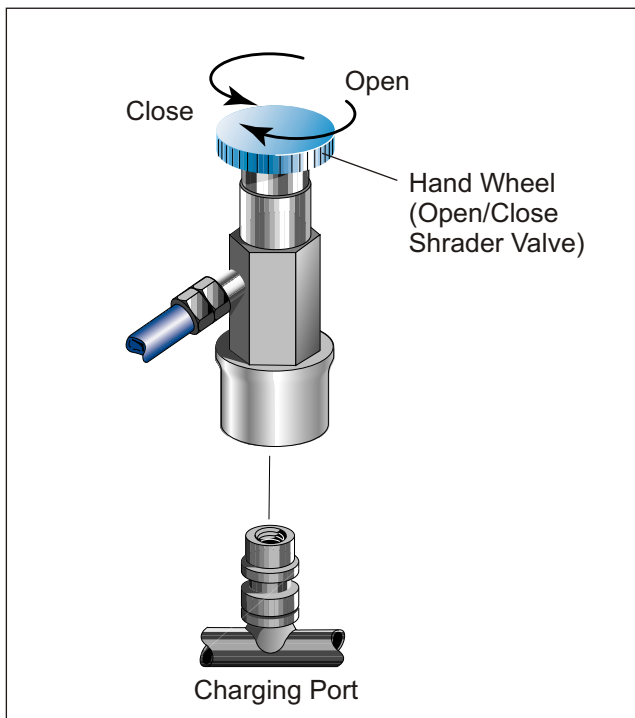

R134a Charging Port

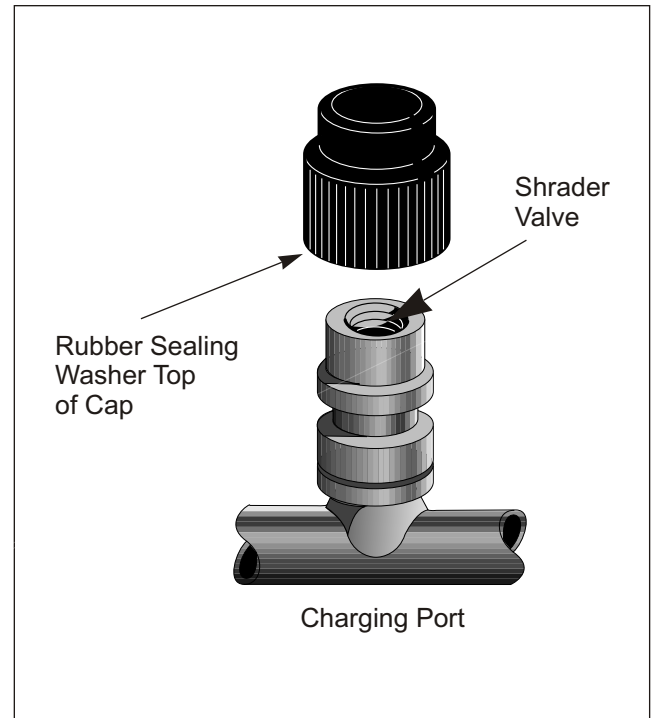

R12 Charging Port

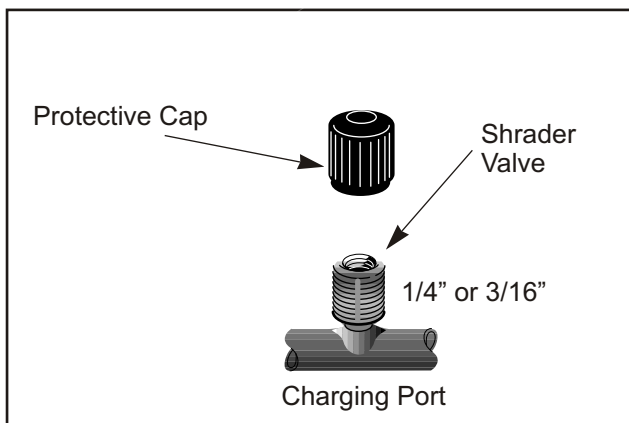

Wiring A/C System

Control/Wiring layout (Series Connection)

Pressure switches are connected in series with the compressor clutch. If an "under" or "over" system pressure occurs the pressure switch will "open circuit" breaking the circuit to the compressor clutch.

With electronic fuel injected vehicles the ELECTRONIC CONTROL MODULE (ECM) is usually interconnected into the A/C wiring circuit. When the A/C switch is engaged a request signal is sent to the ECM, if the A/C circuit is intact, i.e. the pressure switches are a closed circuit, the ECM activates a relay by creating an earth and power is supplied to the compressor clutch. Also an RPM increase generally takes place to avoid engine stall whilst at idle.

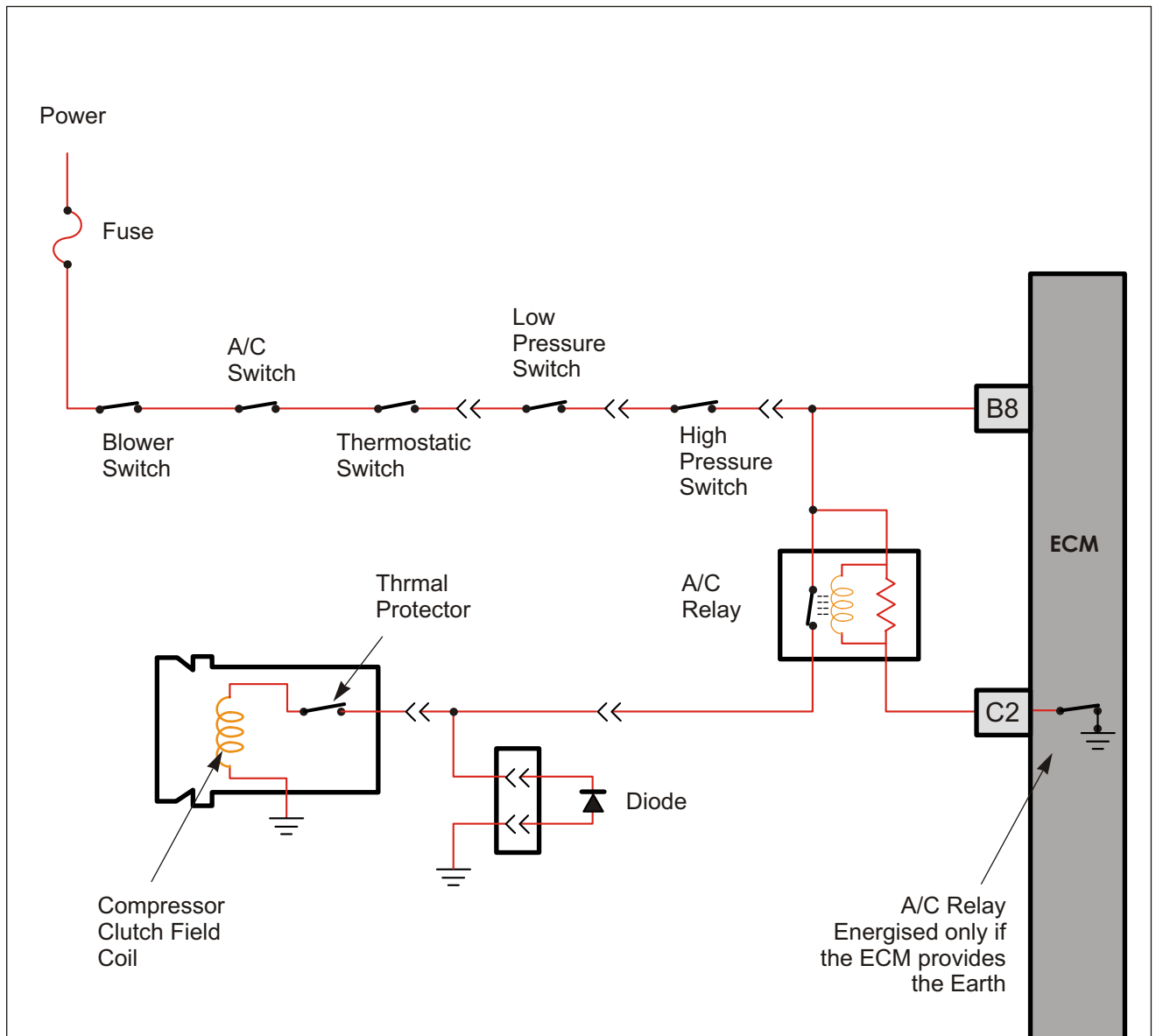

Blower Speed Controls

Coil type

This blower speed regulator simply consists of coiled wires connected in series. These coiled wires are of varied thickness. The current flows through either one or a combination of all the coils. The resistance of the coil(s) alter the blower speeds.

The highest blower speed when selected is normally from direct battery voltage via a relay.

Coil Type

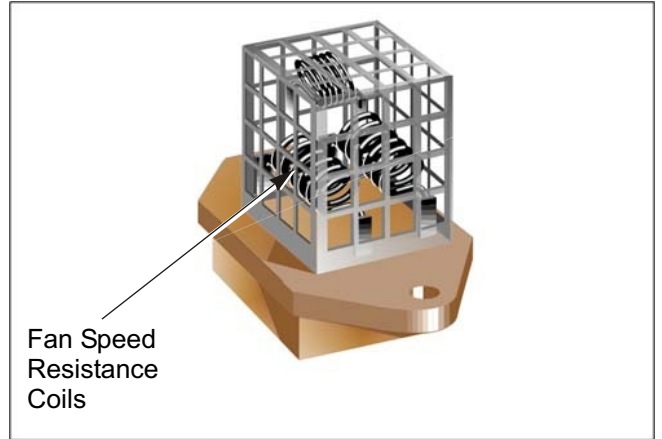

Electronic

The function of the electronic controller is to convert low current signals from the ECM to a higher current, varying the voltage to the blower motor. Blower speeds may be infinity variable and usually can use up to 13 speeds.

This type of speed controller is normally used with the electronic climate control (ECC) system. The highest blower speed when selected is normally from direct battery voltage via a relay.

Electronic Type

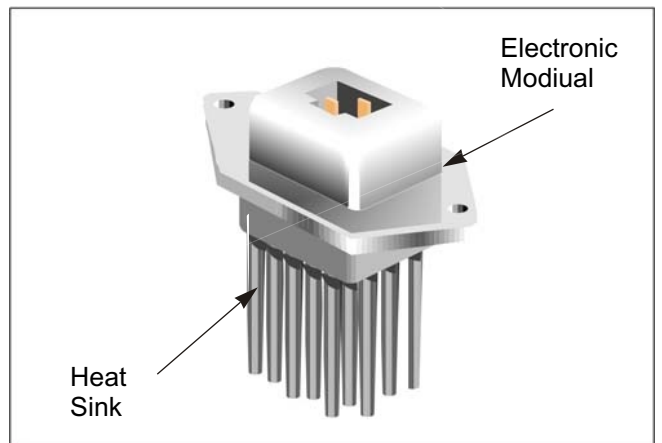

Electronic Type

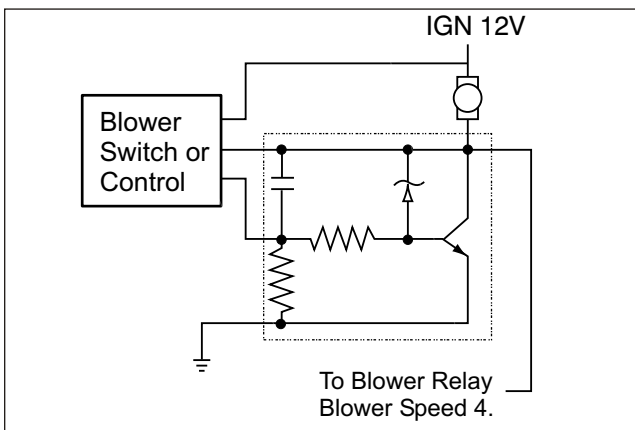

Coil Type

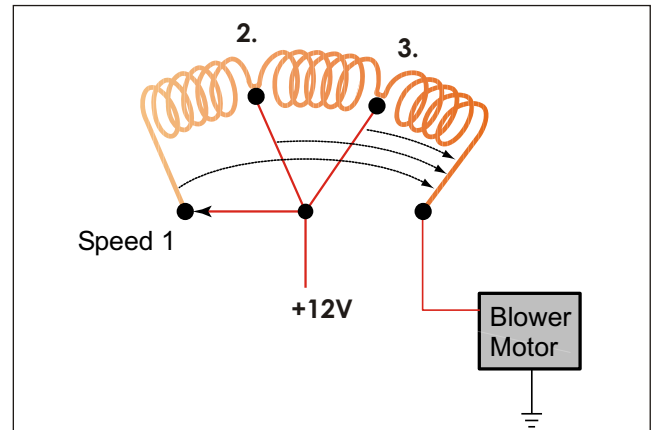

Compressor Cycling Controls

Thermostatic switch (Anti ice-up device)

The thermostat is connected in series to the compressor clutch. When the temperature of the evaporator coil approaches freezing (0°C), this temperature is sensed by the thermostat capillary tube which is in contact with the evaporator fins. The capillary tube contains refrigerant which expands or contracts depending on the temperature on this tube. The points inside the thermostatic switch open up when the refrigerant in the capillary tube contracts (sensing a cold evaporator coil) and interrupt the A/C electrical circuit turning the compressor off. When the evaporator temperature rises again to a preset point (4 - 5 °C) the thermostat points then close. The refrigerant in the capillary tube has expanded (sensing a warmer evaporator coil) and the electrical circuit is re-established to the compressor clutch.

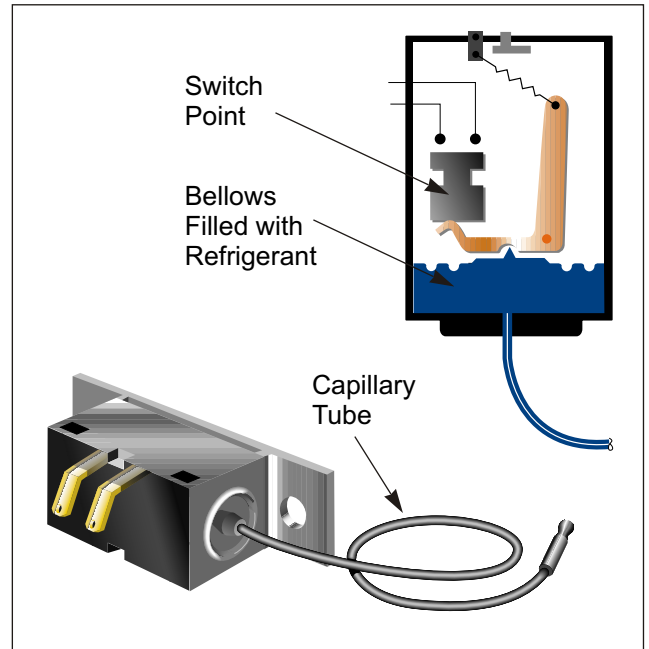

Electrical Circuit

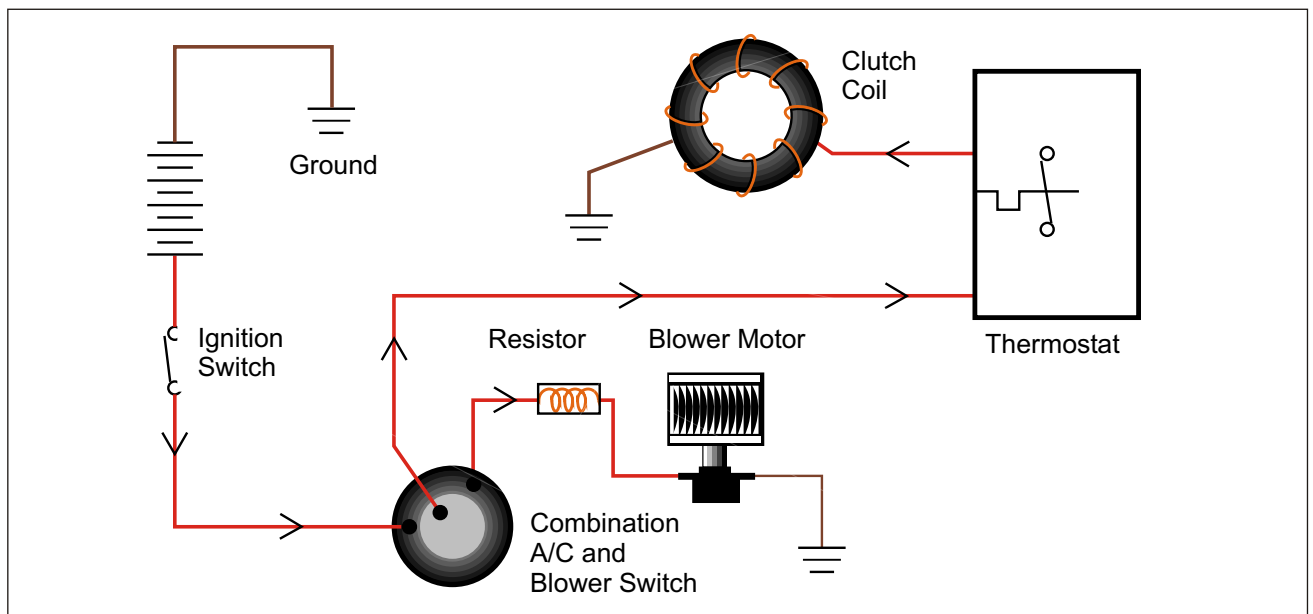

Compressor Cycling Controls

Thermistor & Amplifier

This has the same function as the thermostatic switch except rather than mechanical action with contact points and capillary tube, the thermistor and amplifier is electronically activated. The thermistor is a sensing probe but unlike the thermostat capillary tube it senses the air temperature coming off the evaporator coil.

Thermistor

Electrical wiring containing a sensor which is a NTC resistor.
(Negative Temperature Co-efficient).

Amplifier

A small electronic device containing a circuit board and electrical components. Thermistor resistance is amplified and used to control or switch the A/C clutch on or off.

Economy mode

This function is normally associated with the use of a thermistor amplifier. In economy (ECON) mode the compressor cut out temperature is set higher than a normal A/C mode. This means the compressor stays on for a lesser time, decreasing engine load and improving fuel economy and engine performance.

Center vent temperatures will also be slightly higher due to the compressor cycling off at a higher evaporator temperature.

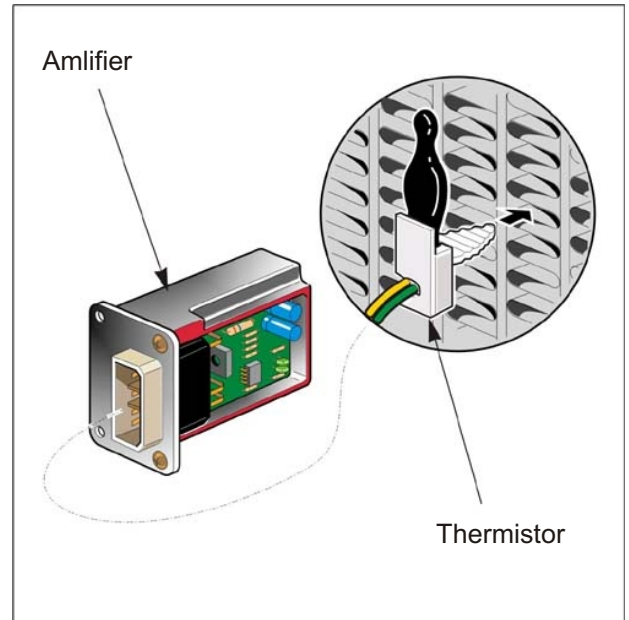

Compressor Cycling Controls

Pressure cycling switch - Electrical

Some vehicles using the Cycling Clutch Orifice Tube (CCOT) system utilize a pressure switch located in the low side of the A/C system between the evaporator and compressor for compressor control.

This pressure switch is electrically connected in series with the compressor clutch.

Once the low side pressure reaches approximately 200 kPa, the compressor clutch is deactivated by the pressure switch opening. A low side pressure of approximately 200 kPa corresponds to an evaporator coil temperature of approximately + 0.40C (above freezing point).

Once the compressor is deactivated the low pressure rises followed by the evaporator coil temperature rising. At a pre-determined low pressure point, the pressure switch reactivates the compressor clutch. The evaporator temperature lowers again and the compressor re-engages.

Note: Normally a low pressure cut off switch is not used with a pressure cycling switch as the pressure cycling switch is located on the low side. It serves as a low pressure cut off also.

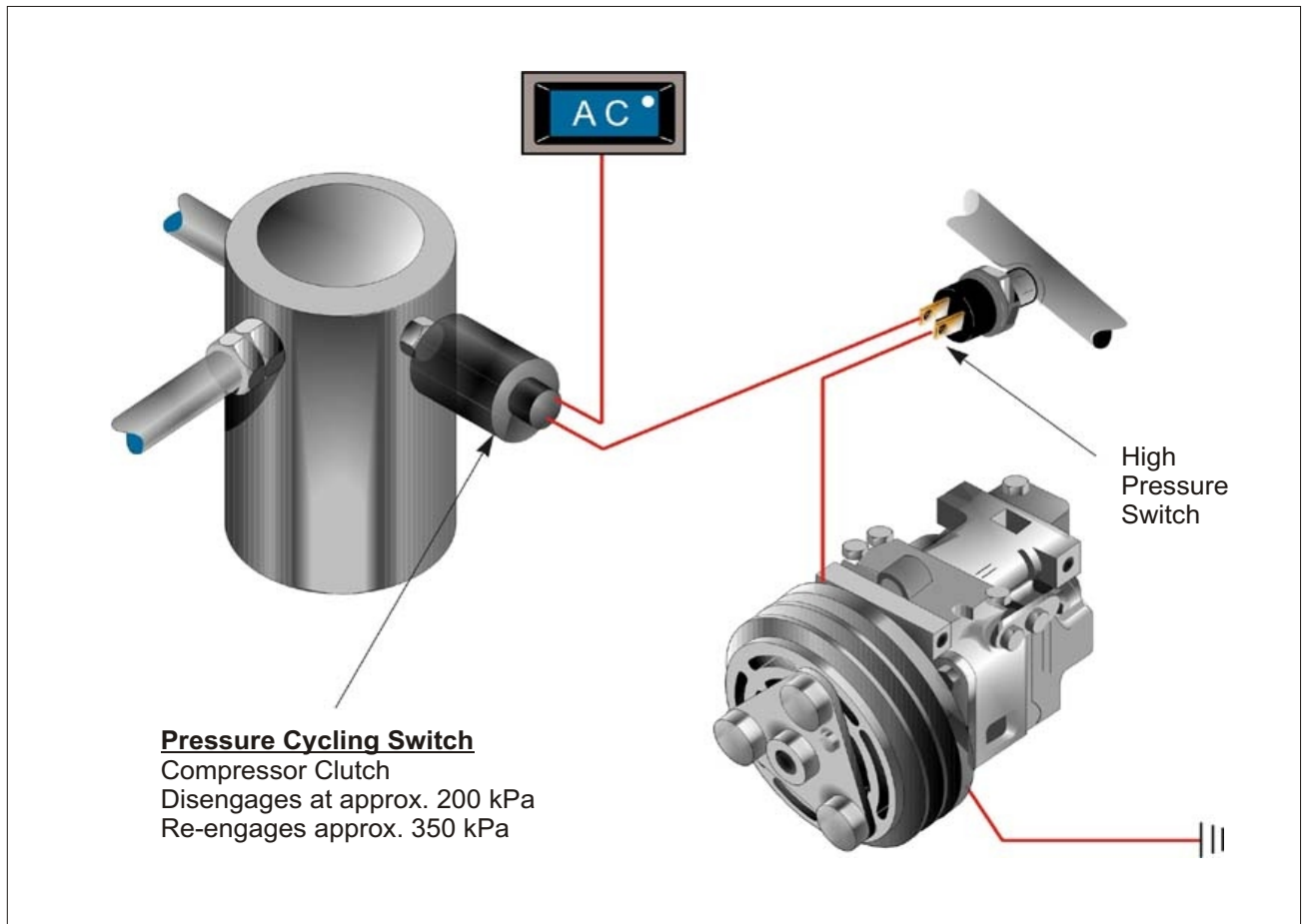

Compressor Cycling Controls

Pressure Control Valve - Mechanical

A/C Demand High

During periods of moderate to high A/C demand, system suction pressure will be greater than the control valve set point. During these periods, the control valve maintains a bleed from crankcase to suction. Crankcase pressure is therefore equal to suction pressure. The wobble plate angle, and therefore compressor displacement is at its maximum.

A/C demand low

During periods of low to moderate A/C demand, system suction pressure will decrease to the control valve set point. The control valve maintains a bleed from discharge to crankcase and prevents a bleed from crankcase to suction. The wobble plate angle, and therefore compressor displacement is reduced or minimized. During these periods, displacement is infinitely variable between approximately 5 and 100% of its maximum displacement.

Harrison Variable Stroke Compressor

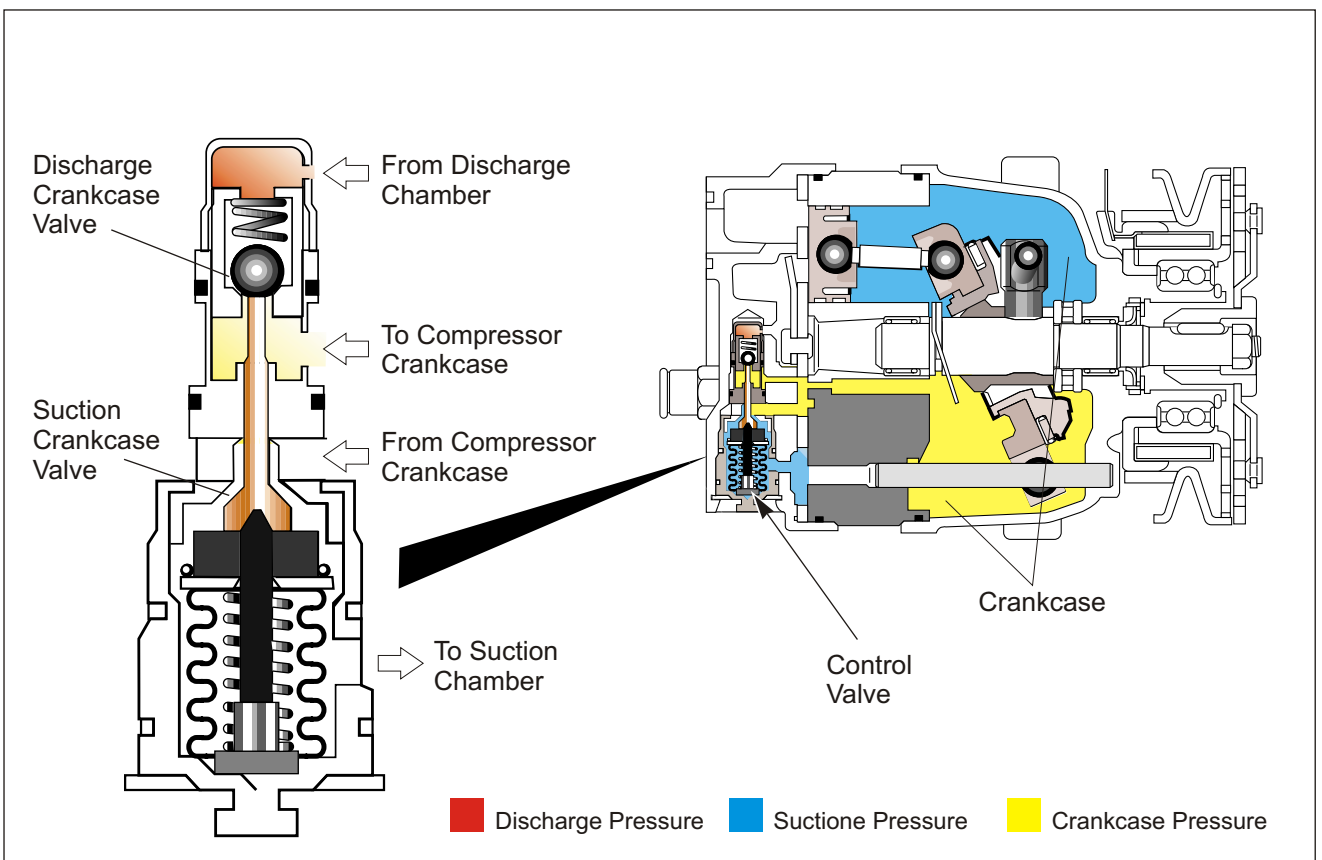

Protection Devices

Clutch Diode

The clutch coil is an electromagnet with a strong magnetic field when current is applied. This magnet field is constant as long as the clutch is applied. When the power is removed the magnetic field collapses and creates high voltage spikes. These spikes are harmful to the ECM and must be prevented. A diode placed across the clutch coil provides a path to ground. This diode is usually taped inside the clutch coil connector.

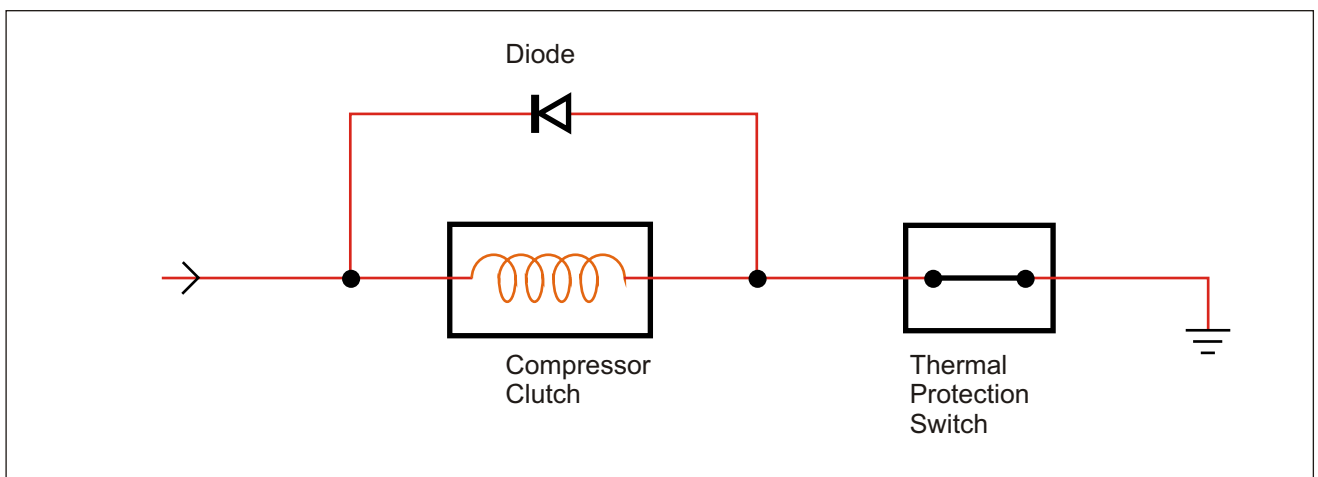

Thermal protection switch

The thermal protection switch is normally located on the compressor housing. This protection switch is used to prevent compressor damage through internal friction.

This switch senses the compressor case temperature and once this case temperature reaches a predetermined figure the electrical circuit to the compressor clutch is interrupted.

As the thermal protection switch is connected in series with the compressor clutch once the compressor case temperature lowers to a predetermined figure the compressor clutch is then re-energized.

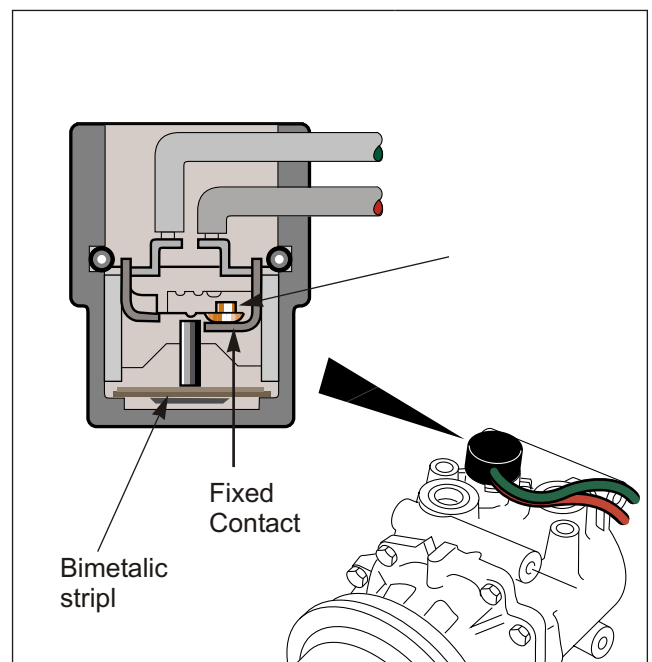

Protection Devices

Refrigerant Pressure Switches

Low pressure

Used to interrupt the electrical circuit to the compressor clutch. If the refrigerant pressure is too low or a problem exists in the A/C refrigerant system. (refer diagram).

High pressure

The power supply is interrupted when the refrigerant pressure is too high or a problem exists in the A/C refrigerant system.

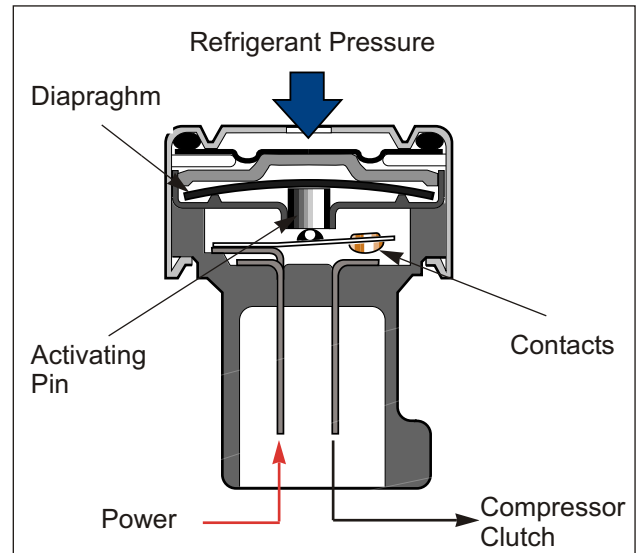

Terminology

Binary switch - High/Low switch.

Trinary switch - High/Medium/Low switch.

Condenser fan control

Medium pressure

Used to engage the condenser fan at a pre-determined refrigerant pressure.

Example: Condenser fan high speed activation at 1770kPa refrigerant pressure.

These switches can be individual or a combination of the two or even three pressure ranges.

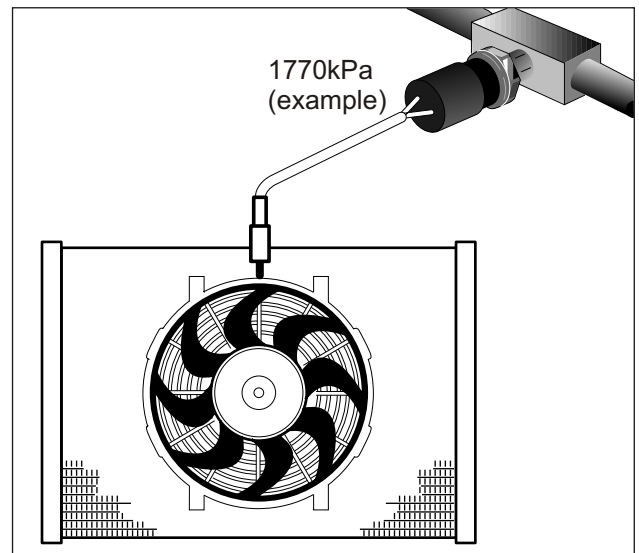

Protection Devices

Pressure Transducer

The pressure transducer is a sealed gauge reference, capacitive pressure sensor with on board signal conditioning. It provides a 0.5 volt output and requires a 5 volt regulated power supply.

In operation the transducer sensor applies pressure via the deflection of a two piece ceramic diaphragm with one half being a parallel plate capacitor. Changes in capacitance influenced by the refrigerant pressure under the ceramic diaphragm are converted to an analog output by the transducer integral signal electronics.

The pressure transducer's electronics are on a flexible circuit board contained in the upper section of the transducer and provide linear calibration of the capacitance signal from the ceramic sensing diaphragm.

Benefits of using the pressure transducer over a normal type pressure switch is that the transducer is constantly monitoring the pressures and sending signals to the electronic control module (ECM), unlike the normal type pressure switch that has an upper and lower cut out points. The ECM will disengage the A/C compressor at low or high refrigerant pressures and electronic diagnostic equipment can be used to extract system pressure information making it easier when diagnosing problems.

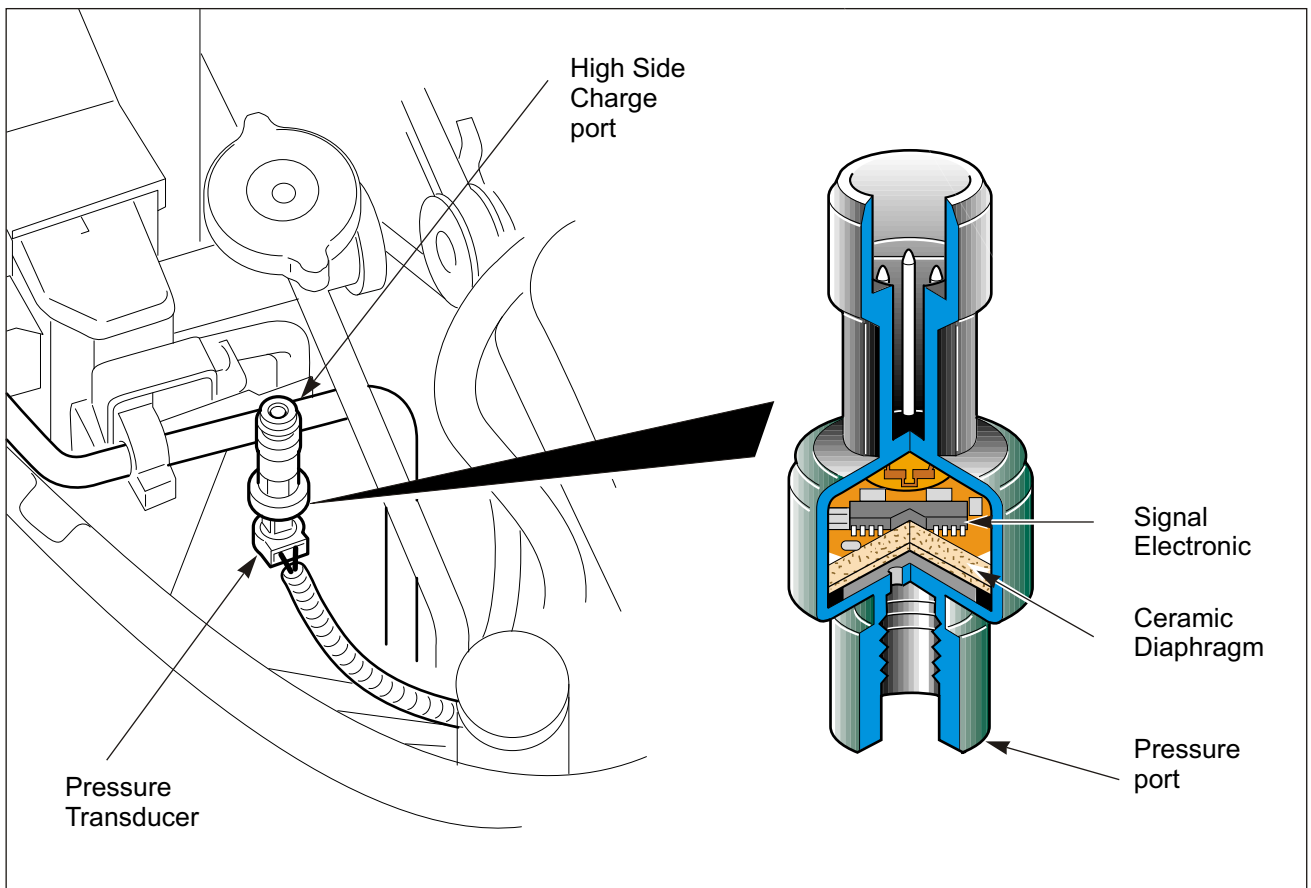

Protection Devices

Engine Control Module (ECM)
Body Control Module (BCM)
Power Train Module (PCM)

Microprocessors (ECM, BCM & PCM) are used to engage and disengage the A/C electrical circuits controlling the compressor and condenser fan.

Numeric signals from various sensors relating to engine speed, road speed, coolant temperature, A/C switch activation, pressure switches, A/C thermostatic switch, throttle position and kickdown are constantly monitored by the ECM, BCM or PCM. These numeric signals are converted in the microprocessors to calculations required to:

- Deactivate the A/C compressor at high/low system pressures;
- Deactivate the A/C compressor at kickdown;
- Active and deactivate the condenser fan;
- Increase engine idle speed when A/C system is activated;
- Deactivate the A/C compressor at high engine RPM;
- Delay A/C compressor engagement at engine cranking;
- Activate electrical engine fan at predetermined coolant temperature;
- Deactivate the A/C compressor when coolant temperature excessive;
- Deactivate the A/C compressor at wide open throttle (WOT)

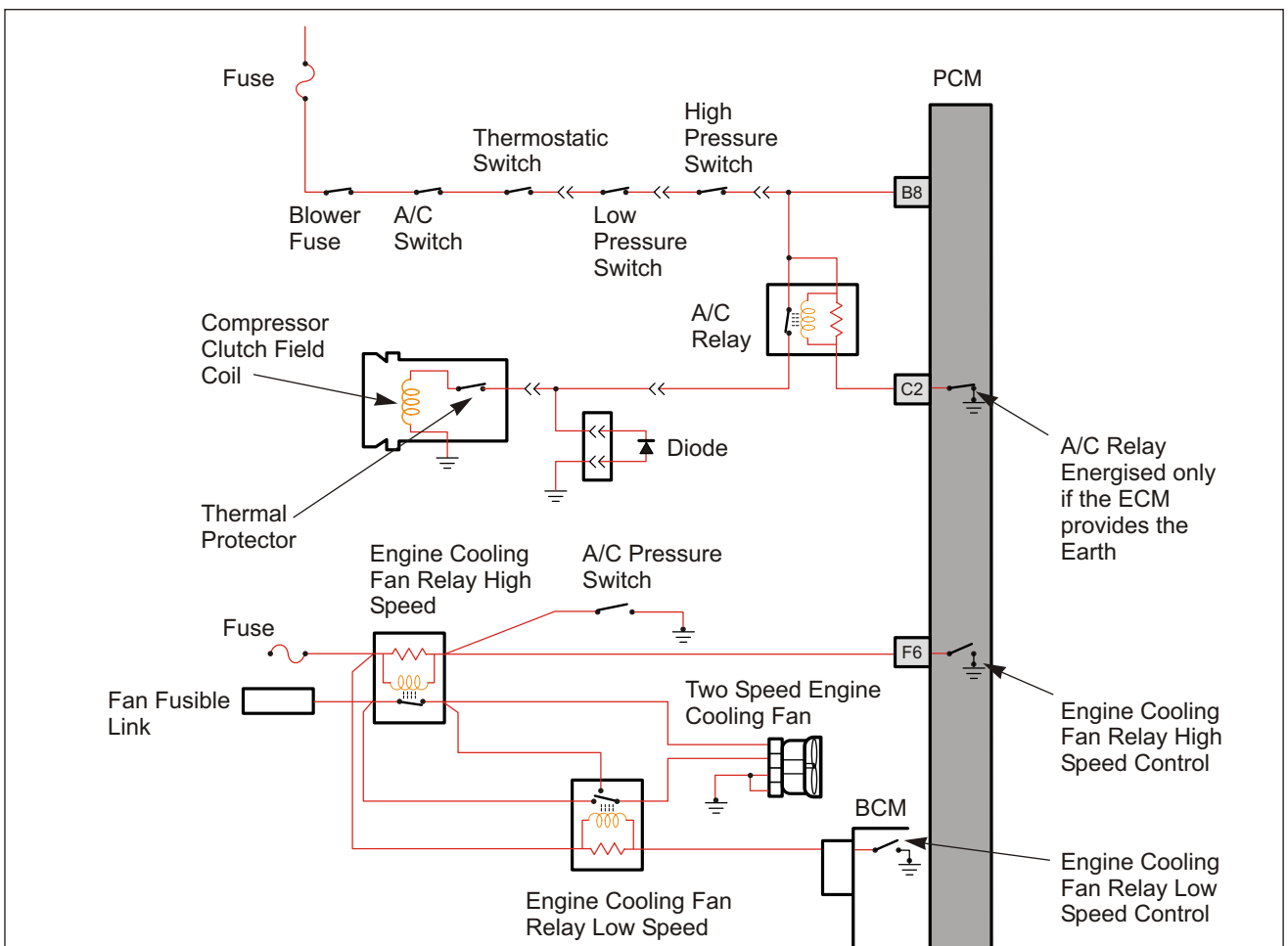

Protection Devices

Relays

Relays are normally used in the A/C electrical circuit to protect switches that have a low current carrying capacity (i.e. a small contact area/weak pressure contact point) or for current draw differences between components.

Shown below is an example of the difference in a circuit with and without a relay.

Without Relay

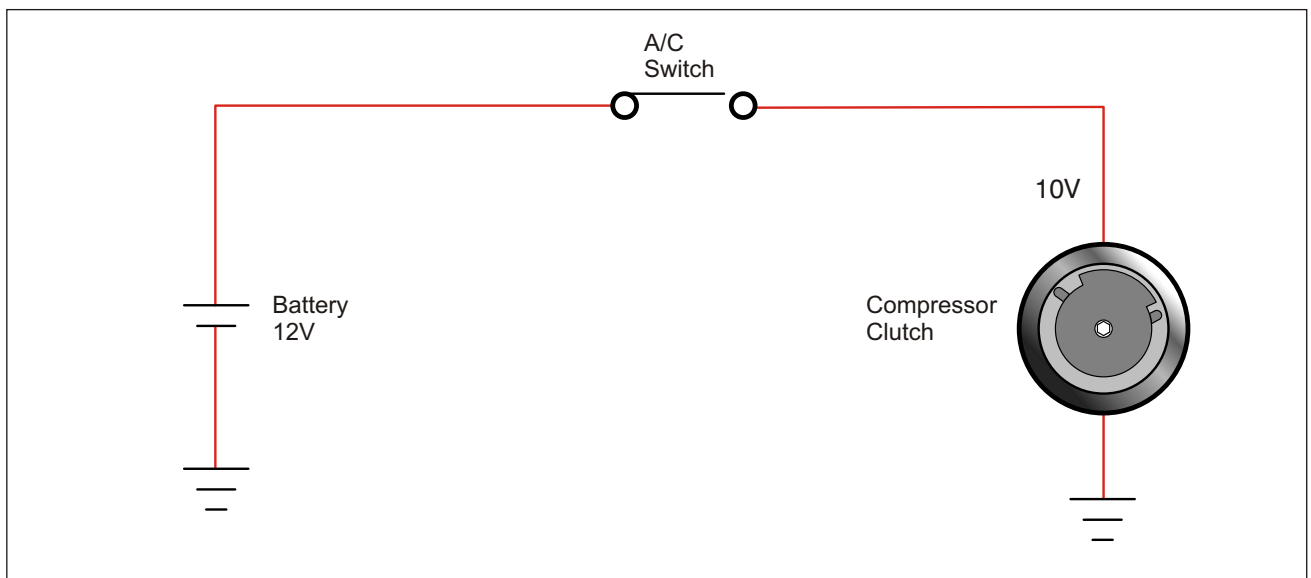

With Relay

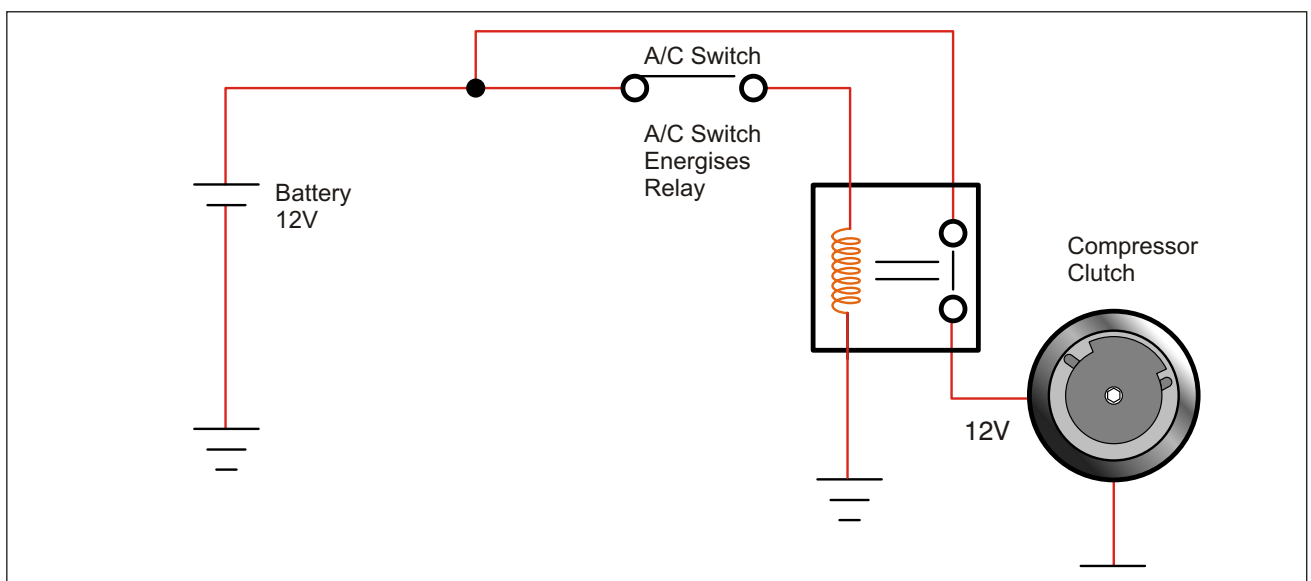

Sensors

Sunload

The sunload sensor is a photochemical diode (PCD) located on top of the dashboard. This sensor sends a signal to the electrical climate control module (ECCM) indicating the strength of the sunlight (sunload) which influences the vehicle interior temperature.

If the sunload is high as signaled by the sunload sensor the ECCM will activate the highest blower fan speed and maximum cooling to compensate for this additional radiated heat load. Likewise, if the sunload is low (cloud cover) as sensed by the sunload sensor, the ECCM will reduce the blower fan speed and the system will not operate at maximum cooling.



Ambient temperature sensor

The ambient temperature sensor is a negative coefficient resistor (NTC) with low voltage input. The sensor alters resistance depending on the ambient air temperature surrounding it.

The sensor is located in the ambient air stream normally behind the bumper bar or front grille area. This sensor is used to monitor the outside temperature and is interconnected to a visual display in the instrument panel.

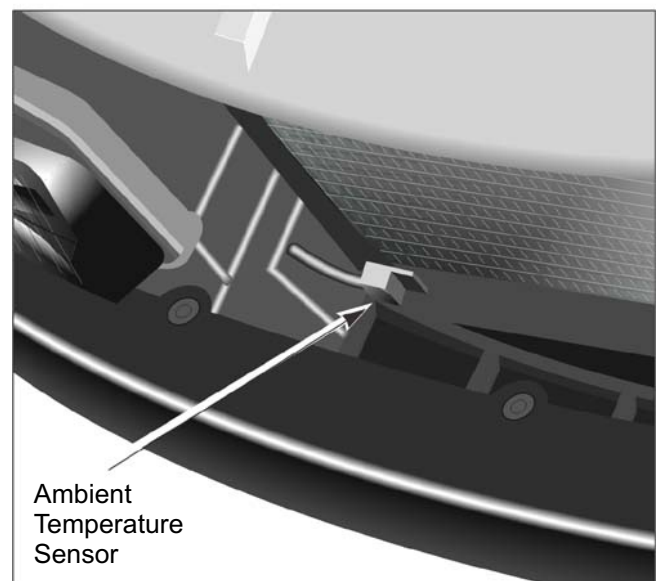

Temperature Control

Air Mix Door

Temperature control is carried out by operating the temperature mode control, normally cable operated and connected to a door housed in the heater case. This door is located above the heater core and in the full cold position, completely covers the heater core. As more heat is required the door is operated and moves away from the heater core and allows radiant heat to rise and mix with the fresh or A/C air to increase the vent temperatures to the desired comfort level required.

Air Flow during Maximum Hot

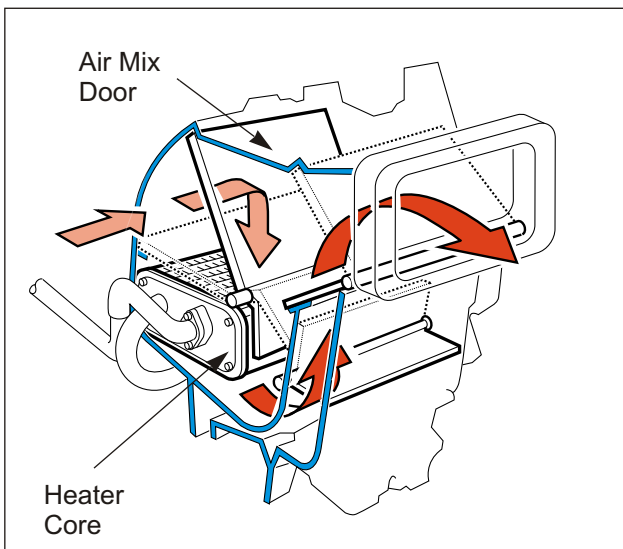

Air Flow during Maximum Cold

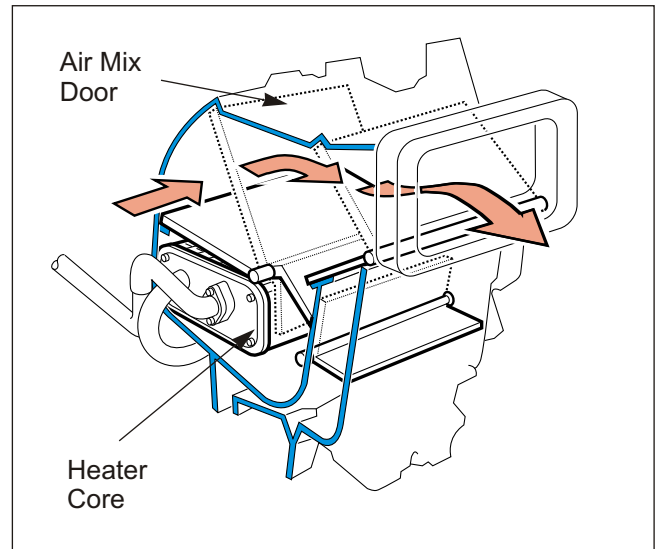

Heater Control

The heater tap is normally vacuum operated and has engine vacuum applied to it in the full cold position. This stops the flow of coolant to the heater core by keeping the heater tap closed. Once heating has been selected, the vacuum is exhausted from the vacuum circuit via a vacuum switch, to the heater tap and the hot coolant then flows through to the heater core.

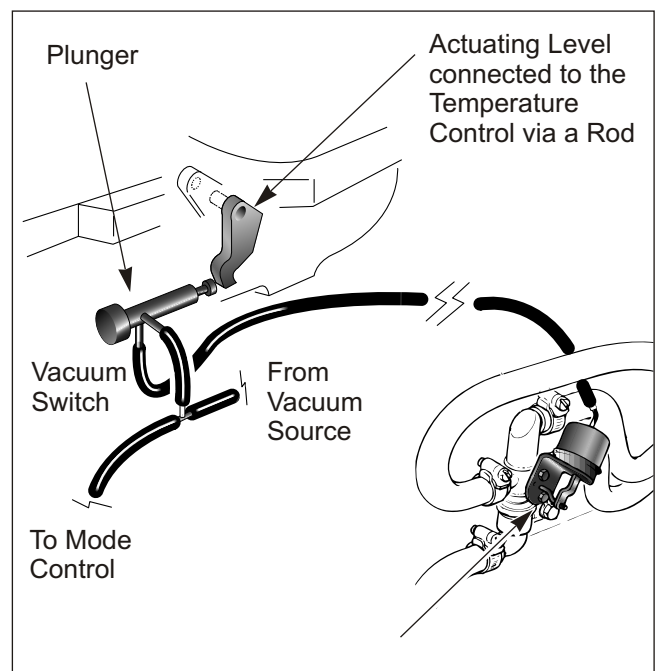

Mode Control

Vacuum Actuators -Single & Dual stage

The various air distribution duct doors located in the heater-A/C case are open and closed using a vacuum actuator.

The vacuum actuator consists of a plastic or metal container housing, a spring, rubber diaphragm and a connecting rod. Once vacuum is applied, the rubber diaphragm is pulled back bringing with it the connecting rod which is connected via a lever to an air distribution door and compressing the spring. When the vacuum is removed, the spring pushes the diaphragm and connecting rod back to original position.

Single Stage

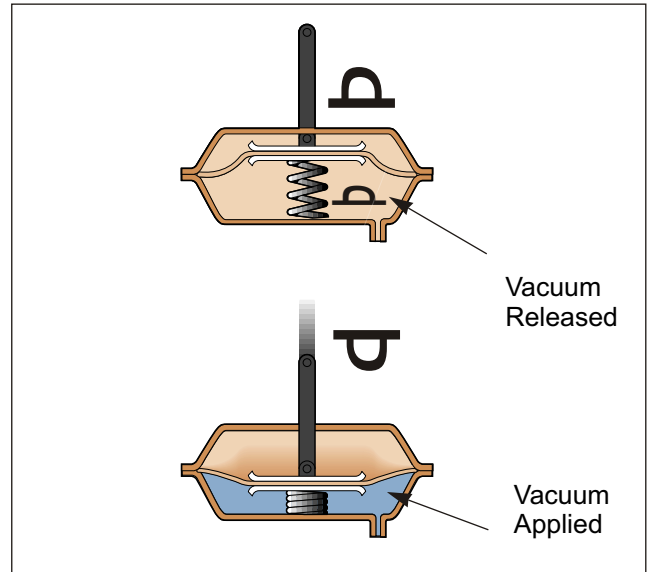

Dual Stage

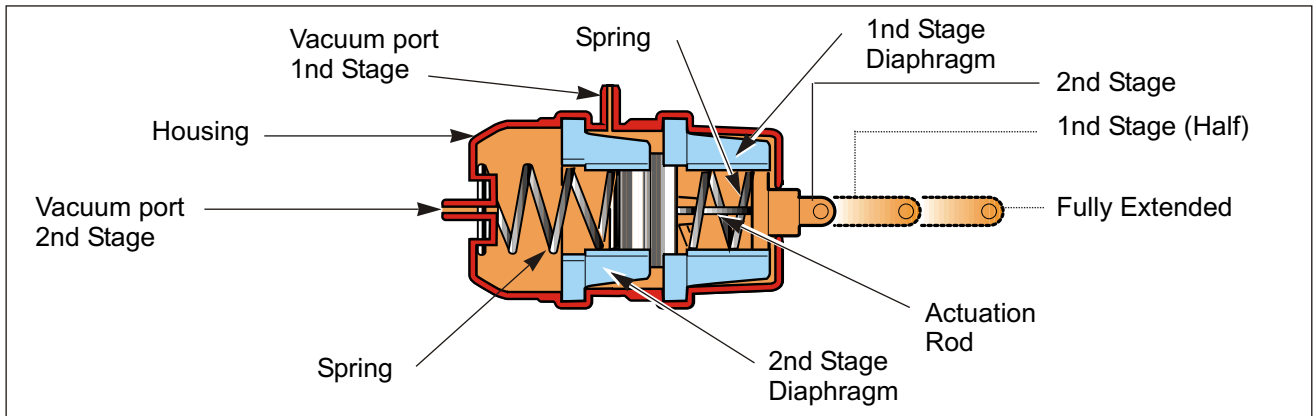

Vacuum circuit

Vacuum is directed to the desired distribution duct vacuum actuator, from engine intake manifold vacuum.

A vacuum switch attached to the mode control knob redirects vacuum to the desired vacuum actuator.

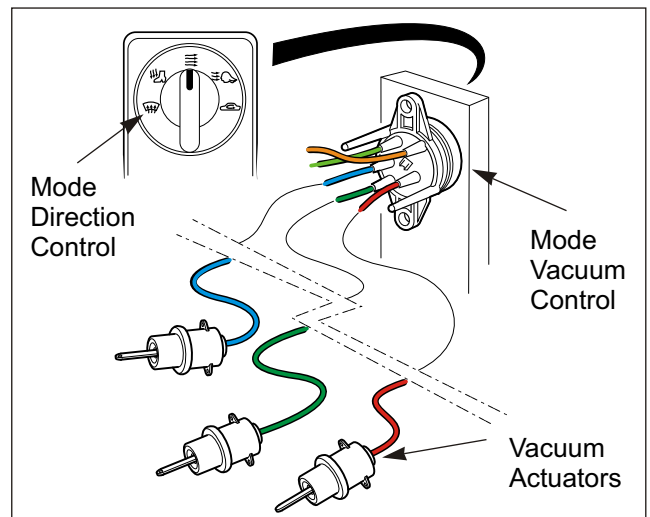

Mode Control

Air mix motors

The air mix motor is actually a potentiometer balance resistor (PBR). It comprises of small electrical motor, gears of varying sizes, a drive shaft and a printed circuit board. It is attached by means of a drive shaft to the air mix or temperature mode door main shaft. This motor regulates the temperature by moving the door closer to (cooler) or further from (hooter) the heater core.

Variable low voltage signals are sent from the electronic climate control module (ECC) to move the air mix motor - which in turn moves the temperature mode door, to a predetermined position to regulate the vehicle interior temperature. The air mix motor position signals are also sent back to the ECC for reference as to where the air mix/mode door is positioned.



Vacuum solenoid pack

This method for operating the vacuum actuators is normally used in conjunction with the electronic climate control system (ECC). This type of climatic control is fully electronic. The vacuum actuators used for various air distribution modes are indirectly engaged and disengaged electronically via the vacuum solenoid pack.

The solenoid pack consists of a group of electrically activated vacuum solenoid valves using a common printed circuit board while enclosed in a single housing.

Each solenoid is allotted to a vacuum actuator or vacuum valve (heater valve). Once the vacuum solenoid is energized by the ECC, an engine supplied vacuum can then flow through the solenoid valve to the relevant vacuum actuator to operate a mode. Likewise, once the vacuum solenoid is de-energized it then vents the vacuum from the line and actuator into the atmosphere.

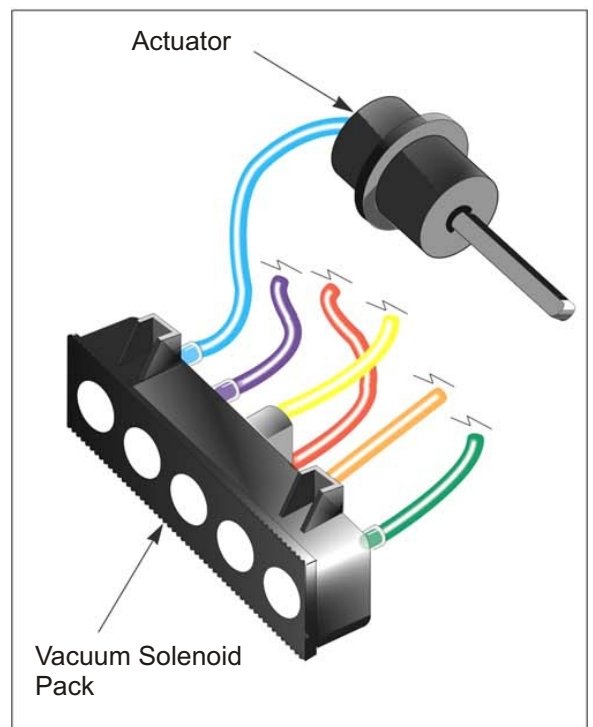

Electronic Temperature Control (ECC)

ECC systems operate with the same basic component as in the manually controlled systems, such as the condenser, compressor, evaporator and heater. The major difference being that the ECC system can maintain a preset level of cooling or heating selected by the vehicle operator once the automatic mode is selected.

Electronic sensing devices allow the ECC to respond to various changes in sunload, interior cabin temperature and ambient temperature. The ECC system will adjust automatically to any temperature and climatic changes to keep the vehicle cabin interior within the pre-selected temperature range.

This is accomplished by adjusting:

- Blower fan speed
- Air mode positions
- A/C activation
- Heater tap activation
- Air mix door movement
- Fresh/Recirc door position

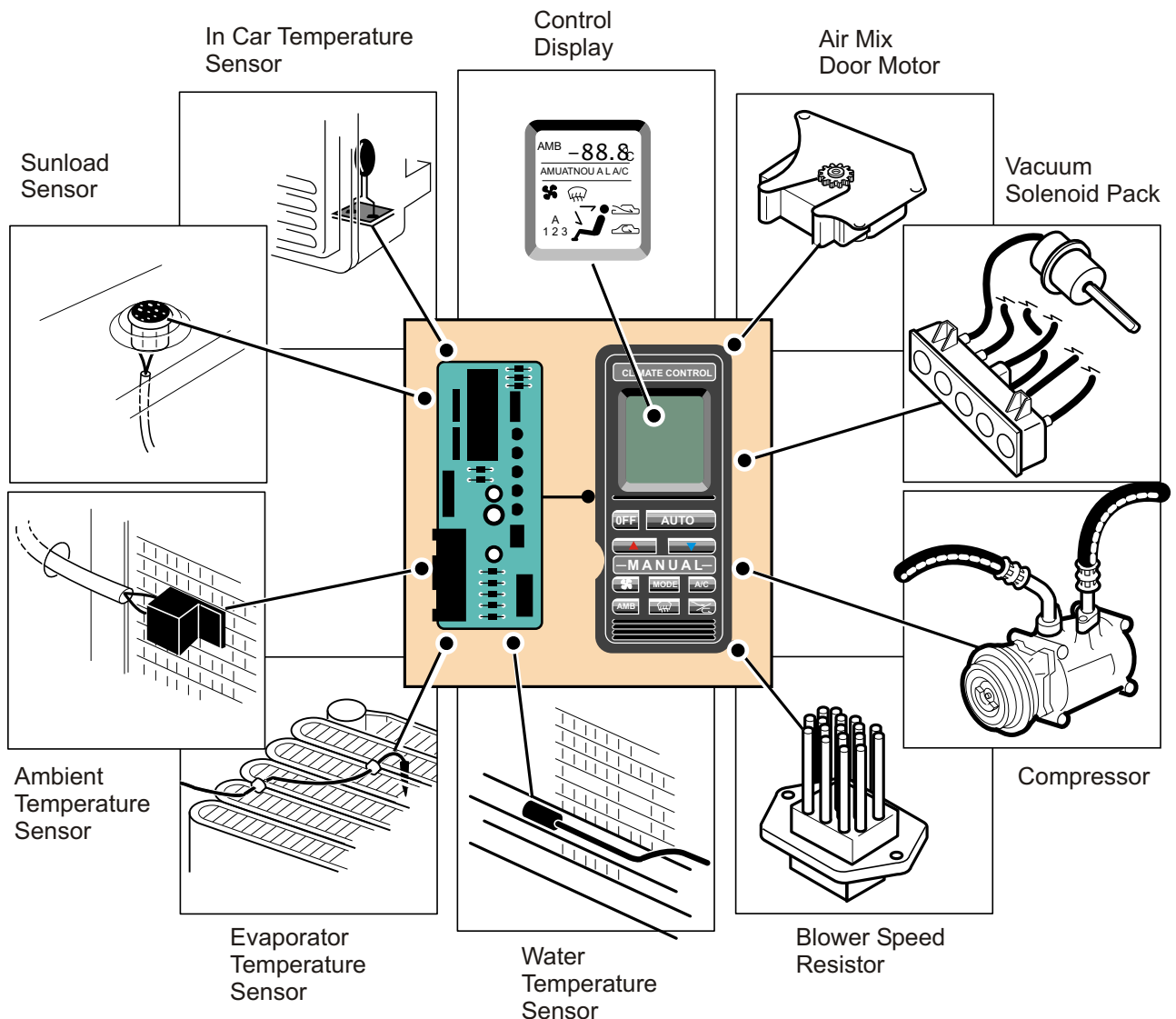

Electronic Temperature Control (ECC)

Whilst the systems main benefits are attained on the AUTOMATIC mode, the option for manual override exists. But once manual mode has been selected by pushing the fan speed, A/C or mode switch, it takes away a function normally controlled by the processor in the ECC module making the processor adjust an alternative component to attain the pre-selected temperature.

An additional benefit of the ECC system is a self-diagnostic function which when used will greatly reduce the time spent locating system faults.

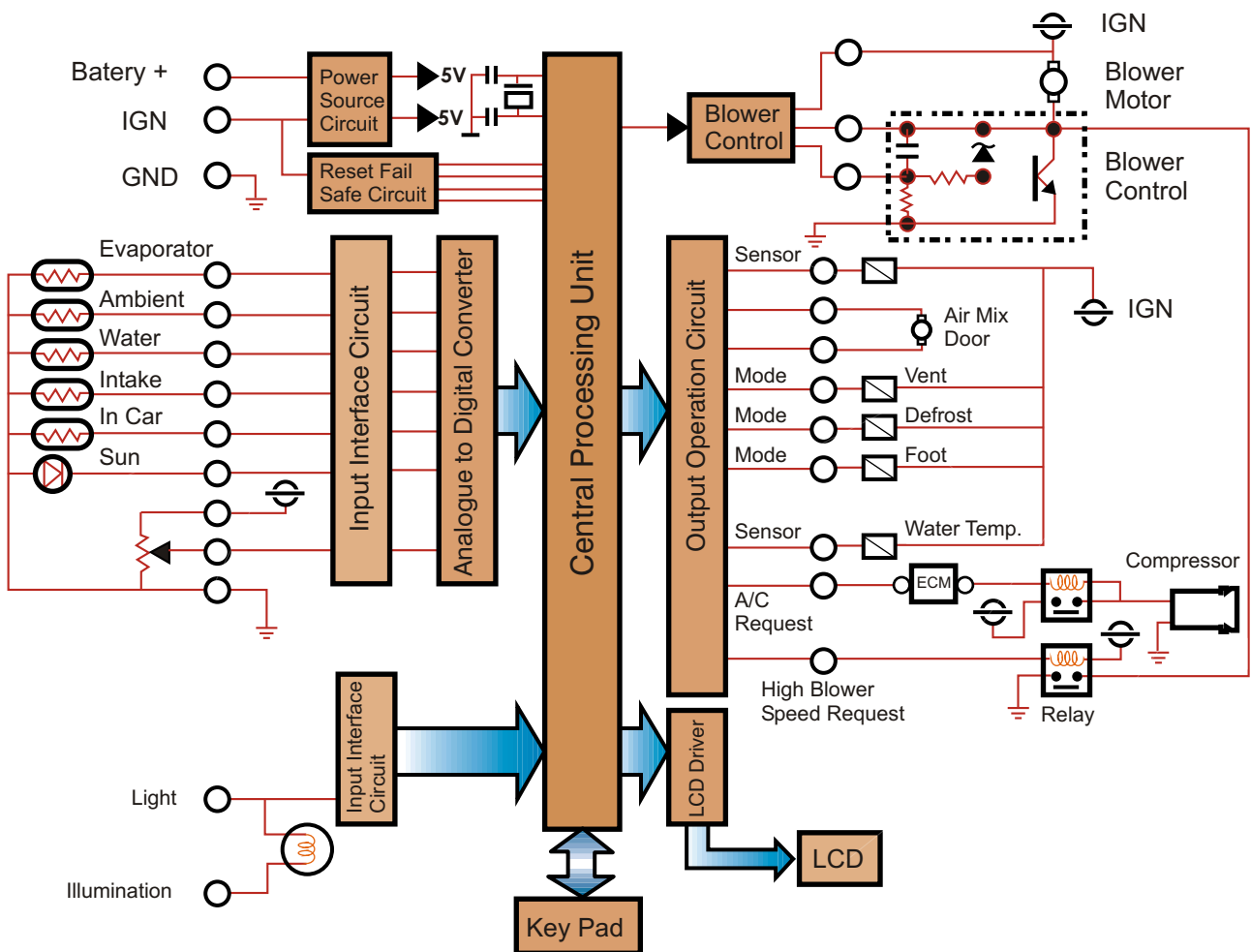

From refrigerant R12 to R134a

Introduction

With the accelerated phase out of R12 (1 st January 1996) many compromises have to be considered and quite possibly accepted in retrofitting on an alternative refrigerant such as R134a.

No direct "drop in" replacement is available, even alternatives such as ternary blends require the replacement of components such as "O" rings on some systems, filter dryers or accumulators.

System lubrication: Majority of automotive manufacturers recommending PAG (Poly Alkaline Glycol) oil as the only oil replacement when retrofitting R12 automotive A/C systems to operate on R134a refrigerant.

Ariazone also recommends POA oil which is fully synthetic oil and suitable with all compressors + refrigerant R12 and R134a.

It is also recommended that if an R12 A/C system is functioning correctly and no refrigerant leaks are present do not retrofit until absolutely necessary i.e.

- Replacing a major component such as the compressor or condenser.
- When R12 is no longer available.
- Accident damage.

Cost will be a very important issue if an R134a retrofit is to be undertaken, but do not sacrifice performance and reliability for the sake of cost. As further documented there will be slight temperature and pressure increases within the system. This will all depend on how the A/C system originally performed on R12 if the performance was marginal on R12 a retrofit to R134a will not improve that performance.

Retrofitting the A/C system is probably the simplest part. The most important part prior to retrofitting will be the time spent talking to the owner discussing:

- What A/C repairs were last carried out and when?
- What parts were replaced?
- Is the A/C system already operating on alternative refrigerant?
- Is the A/C functioning/operating okay presently, if not, ask the owner for any known history of problems?
- How long do they intend keeping the vehicle? Do you replace the condenser with more efficient design? Explain associated costs to the owner.
- What warranty will be offered on the retrofit?
- Any defects and leaks will have to be repaired before the R134a retrofit can take place. - These costs will be over and above the retrofit price.

From refrigerant R12 to R134a

1. Initial Inspection - A full visual inspection of all components, hoses, sign of leakage, corrosion, also look for warning labels indicating what refrigerant is in the A/C system, an alternative refrigerant could already have been used.

(NOTIFY THE OWNER OF EXTRA PARTS REPLACEMENT ABOVE RETROFIT COST REQUIRED TO BRING THE A/C SYSTEM BACK TO A FULLY OPERATIONAL CONDITION).

2. Performance check - Start engine, engage A/C, operate for 10 minutes at 1500 rpm, on maximum cooling and highest fan speed, insert thermometer probe into the center vent and connect R12 pressure gauges. If required add sufficient R12 refrigerant (if available) to bring the A/C system pressures and center vent temperatures to the manufacturers specifications. Take note of the pressure and temperature readings.

(NOTE: RUNNING THE A/C SYSTEM FOR 10 MINS ETC. WILL ENSURE THAT MOST OF THE MINERAL OIL WILL BE TRAPPED IN THE COMPRESSOR).

Check condenser airflow for restriction/obstructions, such as insect screens, grass seeds and insect build up over the condenser face, and also for any signs of system overheat.

3. Leak checking - Carry out complete leak check (to SAE J1627) using a dedicated R12 leak detection device. (To SAE J1627)

(NOTIFY OWNER OF EXTRA PARTS NEEDED TO BE REPLACED ABOVE RETROFIT COSTS).

4. R12 Recovery - Recover refrigerant from the A/C system using a dedicated R12 recovery device (to SAE J1990).

5. R12 Parts replacement - Remove the components to be replaced as part of the retrofit to R134a, as recommended by the A/C system or vehicle manufacturers guidelines.

THE MINIMUM:

- Filter drier or accumulator;
- High side system "O" rings through to the evaporator inlet;
- Add 30-50ml PAO oil to a/c system.
- Fit high/low side R134a charging port adapters (use a thread lock to secure to R12 charging ports;
- Retrofit warning labels.

6. Flushing option - If when removing components contamination is found i.e. aluminium particles, it would be advisable to flush the system. Components such as the compressor filter drier/accumulator and "O" rings are to be replaced. Flush all remaining components with a recovery device.

7. Evacuation - Using R134a equipment, evacuate the A/C system for minimum of 40 minutes at vacuum of -100kPa.

8. Charging - Charge the A/C system with R134a to approx. 90% of the original R12 charge quantity e.g. original R12 1000 grams, R134a retrofit charge 900 grams.

From refrigerant R12 to R134a

9. Warning/Identification Labels - Remove all labels from the vehicle referring to the REPLACED refrigerant. Affix new R134a warning and oil/change quantity labels (to SAE J1660) to a prominent location in the engine bay. Write on labels all fitment information required in ballpoint pen.

10. Performance Check - Take pressure and center vent temperature readings, compare to the "baseline" information taken in step 2. Remembering that R134a pressures will be 10-20% higher and center vent temperatures possibly slightly higher also.

11. Road Test - Carry out road test, again check performance in the various fan speeds and mode positions. Ensure if in an extended idle situation the compressor does not fast cycle on the high-pressure switch (high-pressure problem).

12. Check + test operation of fresh/recirculating air chamber.

13. Hand over - Explain to customer what exactly has been replaced, and any warranty implications.

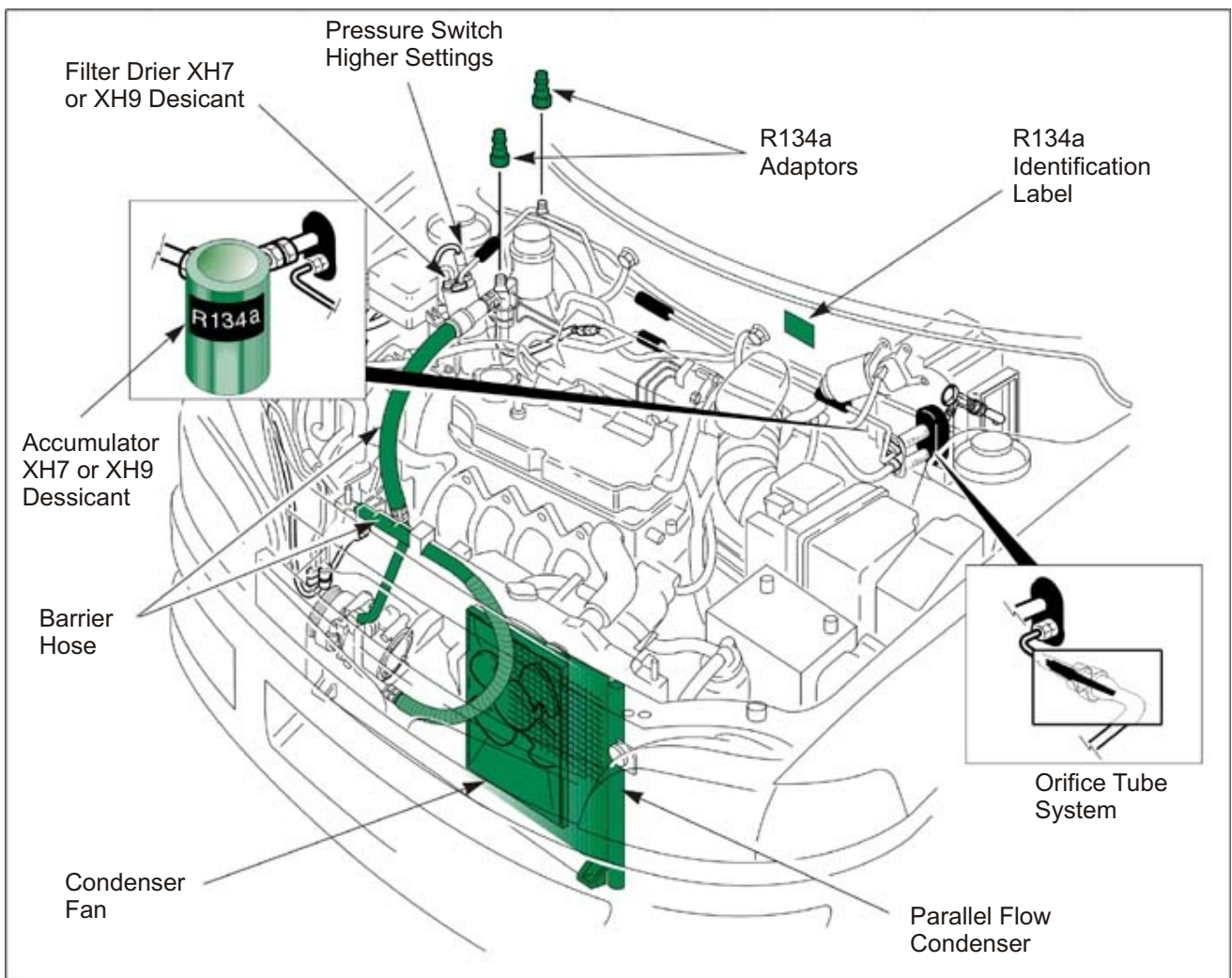

Recovery & Recycling Equipment

R134a is a non ozone-depleting refrigerant but from cost point of view and fact that R134a adds to the green house effect it is still mandatory that it be recovered and recycled.

Due to the fact that most R134a A/C systems have no sight glass in the FDR, you may be required to remove the refrigerant more often and charge to the specified amount.

Important notes:

- Use only a specified R134a Recovery and Recycling equipment.
- Change device filters when suggested by equipment manufacturer.
- Ensure oil collected during recovery is replaced into the A/C system with new oil.

Ariazone 601 - Mini Recovery Unit

The Ariazone 601 is lightweight recovery system for the on site mobile technician or small workshop operator.

This system has been designed to be very user friendly and efficient for every user. Simply connect the Ariazone to the air conditioning system switch on and walk away. The 601 will take care to the rest.

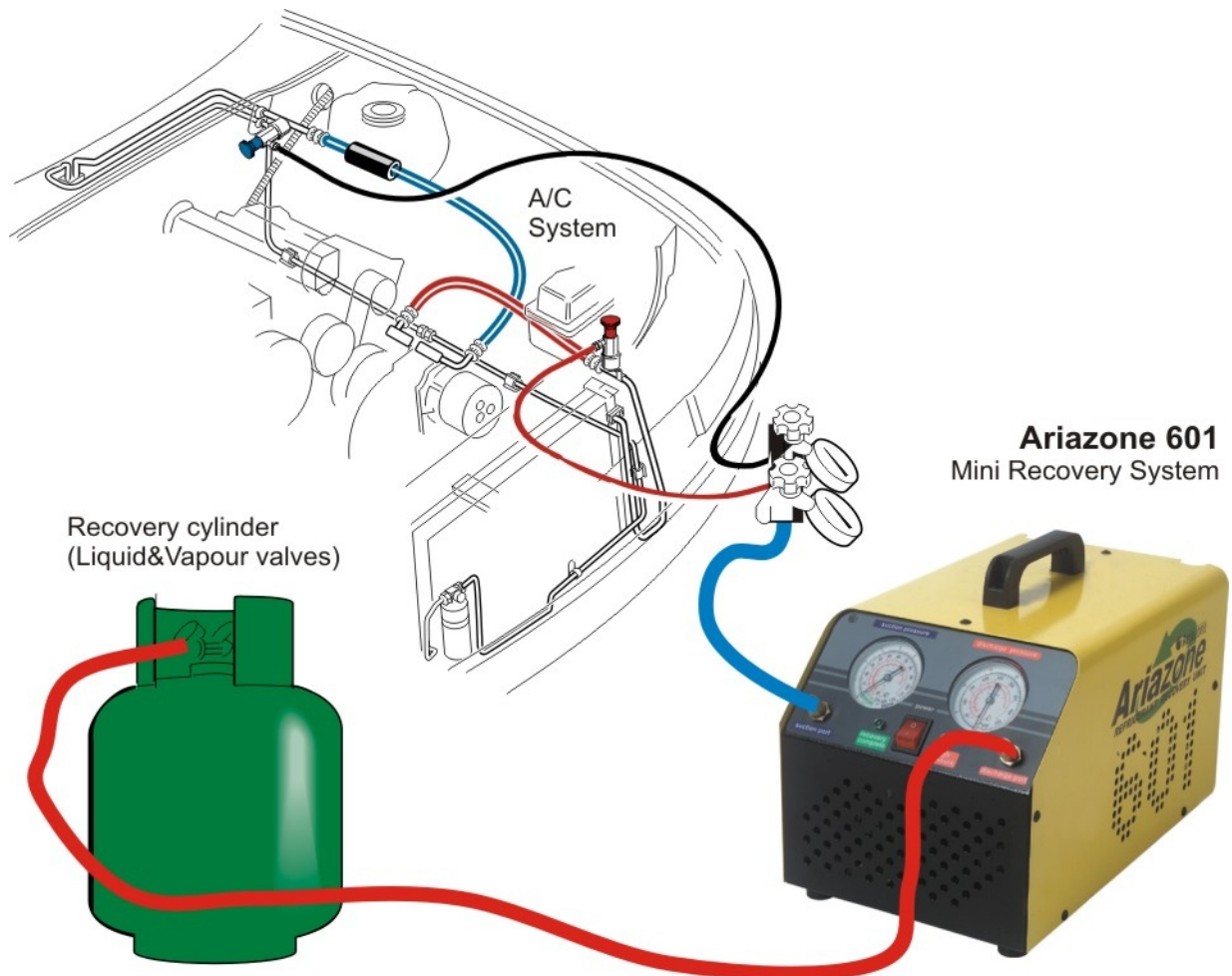

Evacuation Equipment

Fundamentals of dehydrating

The two most frequent questions service technicians ask about dehydration are:

- What size vacuum pump should be used to perform a good A/C system dehydration job;
- How long should the pump be let on the system to assure removal of all moisture.

Moisture in a refrigerant system

While it is important to realize that moisture in a refrigerant system is the underlying cause of most problems and complaints, it is equally important to learn why.

Basically, moisture can be classified as visible and invisible. Occasionally, liquid water is found in system, but this is unusual. Invisible moisture, or water vapor, is culprit which causes the greatest trouble in refrigeration and air conditioning systems.

A single drop of water may look harmless, but to a refrigerant system, it is a monster, the number one enemy of the service technicians. What makes it so formidable is the fact that moisture enters a system easily and is hard to remove. Here is what it does to a system:

First, it creates "freeze-ups". Moisture will be picked up by the refrigerant and be transported through refrigerant lines in a fine mist which forms ice crystals at the point of expansion (expansion valve). Ice crystals retard or stop the flow of the refrigerant, causing loss of cooling. As the expansion valve warms, due to lack of refrigerant, the ice melts and passes through the expansion valve. The refrigerant will then start again until the moisture returns to the expansion valve and once more builds ice crystals. The result is intermittent cooling.

Whether a "freeze-up" actually occurs depends primarily upon the amount of water and the size of the ice particles formed. But a "freeze-up" is not the only problem caused by moisture. **It can also cause corrosion**, which can present serious trouble.

Moisture in form of water can cause corrosion after a period of time. However, moisture mixed with refrigerant creates much more corrosion trouble. Refrigerant such as R12, containing chlorine, will slowly hydrolyze with water and form hydrochloric acids. This acid greatly increases the corrosion of metals and could corrode copper plating.

Heat increases the rate of corrosion due to acids because higher temperatures accelerate the acid-forming process. The acid attacks all the materials it contacts.

Refrigerant oil presents another problem caused by moisture. Refrigerant oil is an exception to the rule that "oil and water don't mix". In fact, some **refrigerant oil attracts moisture and will absorb it rapidly** if left open to the atmosphere. Water-formed acid mixes with refrigerant oil, forming a closely bonded mixture of fine globules. The effect is called "sludging" and greatly reduces the oil's lubrication ability.

Corrosion becomes troublesome from the operating standpoint when metallic surfaces are eaten away and a solid, detachable product is formed. This formation is also known as a "sludge".

Sludge can cause a variety of problems. It will plug fine strainers, expansion valves and capillary tubes. And because it usually contains acids, sludge corrodes whatever it clings to, accelerating system damage.

Evacuation Equipment

The most effective way to eliminate moisture from a system is with a good vacuum pump.

A deep vacuum is capable of removing all moisture from a hermetic system by reducing internal system pressure to the boiling point of water at normal temperatures.

For those being introduced here to high vacuum work, it should be stated that a vacuum pump does not "suck out" the liquid moisture, but rather causes it to boil in to a vapor state which can be harmlessly removed from the system and exhausted through the vacuum pump exhaust.

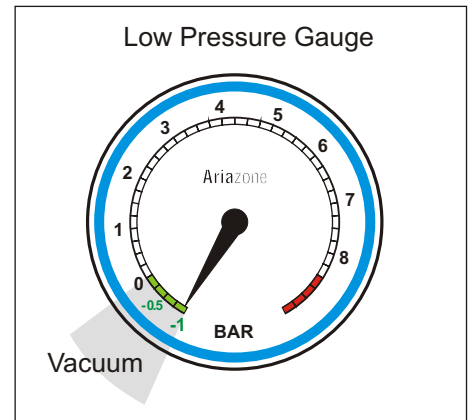

High Vacuum / Deep Vacuum

As stated above, the purpose of a vacuum pump is to reduce the internal system pressure of a refrigeration/air conditioning system so moisture and other contaminants can be removed.

The term "high vacuum" describes the same condition inside a closed system. For refrigeration/air conditioning service applications, high vacuum = good vacuum, or a low micron reading on the system.

Factors affecting the speed at which a pump can dehydrate a refrigerant system

Several factors influence the "pumping speed" of a high vacuum pump and thus the time required to remove all moisture from a refrigerant system. Some of the most important are: the cubic capacity of the system, the ambient temperature present, internal restrictions within the system, external restrictions between the system and vacuum source and the size of the pump, but more important how low a vacuum can it pull down.

The lower number in microns, the better the pump.

Vacuum Station - Ariazone 101

The **Ariazone 101** is a system which conveniently allows the technician to test the air-conditioning systems working pressures, evacuate and inject oil into the air-conditioning system and features a graduated oil injection unit.

Large display, discharge and suction gauges

Oil injection unit

Two stage vacuum pump



Charging Stations

There are two methods of charging refrigerant into an A/C system. They are:

By volume - using a graduated charging dial cylinder,

By weight - using electronic scale with LCD read out.

Both methods work well, but because R134a is charge sensitive and most A/C system filter drier's have no sight glass, it is recommended to charge the system to the manufacturers specification using electronic weighing scales. The advantage of using electronic scale over a dial - a - charge type is that most dial - a - charge cylinders only hold of 2 - 3 kilograms maximum (before being refilled) which is enough for approximately 2 - 3 A/C system charges.

The electronic scales type uses a refrigerant cylinder of up to 25 kilograms enabling 25 - 30 A/C system charges to take place before charging over the cylinder.

Charging by volume

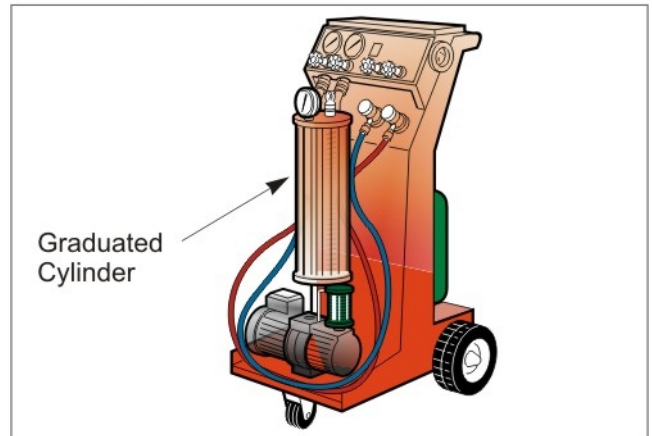

Charging by weight

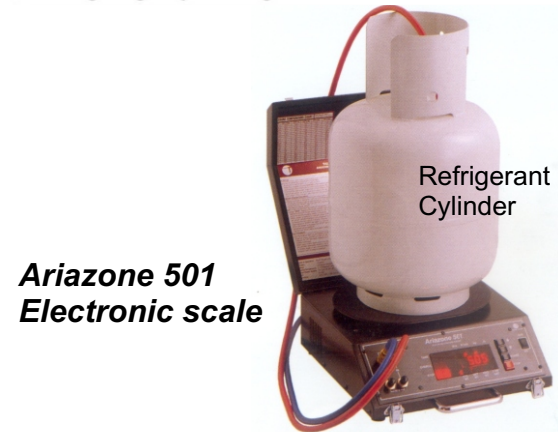

Ariazone 1001 - Electronic Refrigerant Evacuation and Charging System

Ariazone International has developed a smarter refrigerant Evacuation and Charging System using the most up to date electronic intelligence and quality components. The new 1001 unit has been designed for ease of operation, accuracy and durability.

Features:

- Monitors suction and discharge system pressures.
- Displays amount of refrigerant in storage cylinder.
- Operator can select amount of refrigerant to be charged.
- Allows operator to select evacuation time.
- Automatic oil injection.
- Pause function on charge and evacuation procedures.

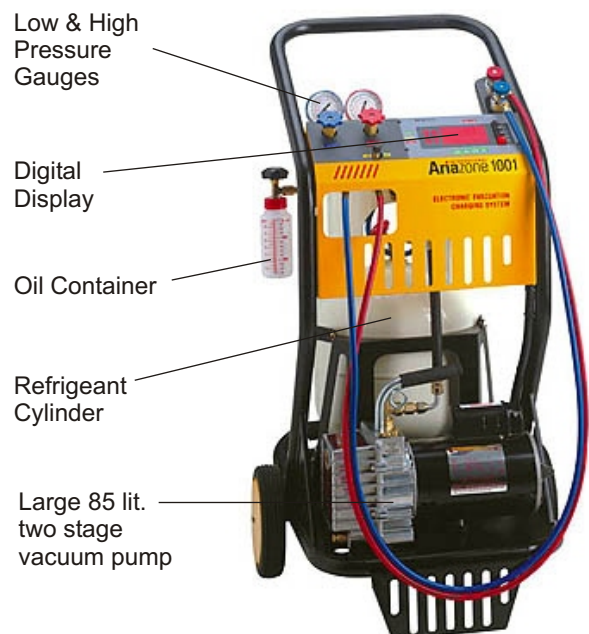

All in One Unit

Rather than have a unit that only recovery, evacuates and charges an A/C system, there are "all in one" units that carry out all the necessary servicing function. Operations are entered into an electronic keypad.

These include:

- *Charging to the specified amount.*
- *Evacuation for any duration required*
- *Recovering the refrigerant.*
- *Recycling the refrigerant.*
- *Injecting the lubricant.*
- *Flushing the a/c system*

All these function can be programmed into the unit via a control panel. The unit will automatically carry out all the pre-selected operations.

Ariazone 500-1 - Recovery& Recycling, Evacuation and Charging System

Ariazone 500-1 takes time and worry out of air conditioning testing and servicing. A once difficult process is now stream-lined and automatically completed by the Ariazone system.

Functions:

- Monitors a/c system working pressure.
- Displays amount of the refrigerant cylinder.
- Recovers and recycles refrigerant with pause function.
- Monitors and displays the amount of refrigerant and refrigerant oil recovered.
- Evacuates system with pause and time function.
- Automatically inject oil or UV dye.
- Electronically charges accurately with pause function.
- Electronically monitors and displays service intervals.
- Electronically refills refrigerant cylinder.
- Prints a reports.



Refrigerant Safety

As R134a has a very low boiling point, care must be taken when it is been handled. The following safety precautions must be followed:

- Always wear eye protection.
- Wear gloves.
- Don't allow R134a to contact bare skin as this causes frostbites.
- Do not heat containers of R134a.
- Provide adequate ventilation when charging or recovering R134a as it is heavier than air.
- Use care when hot water steam cleaning the engine. Hot water on the air conditioning pipes and tubes could create thermal expansion of the refrigerant contained in the system.
- Avoid breathing R134a vapor.
- Do not transfer refrigerant from cylinder to cylinder using a pump without knowing when the bottle being filled has reached 80% of its capacity, as a remaining 20% is used for thermal expansion.

Eye Protection

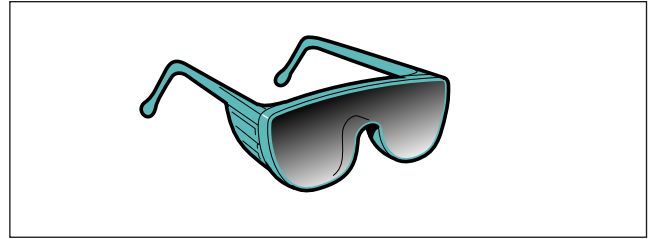

Hand/Skin Protection

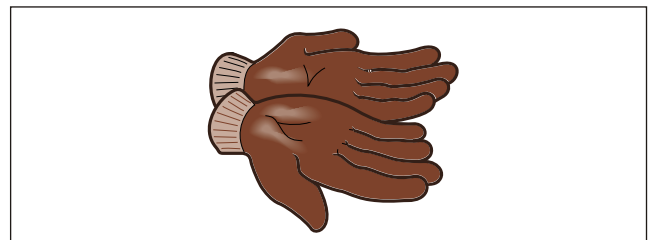

Do Not Heat Container

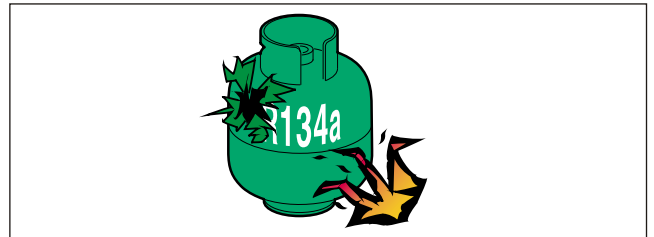

Do Not Transfer Refrigerant

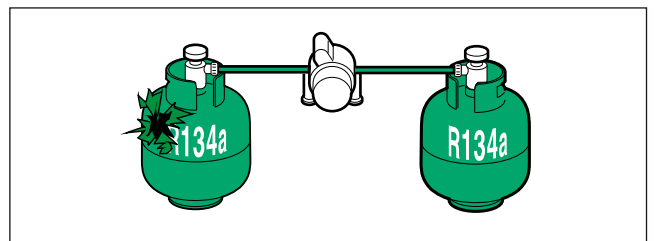

Avoid Breathing Refrigerant

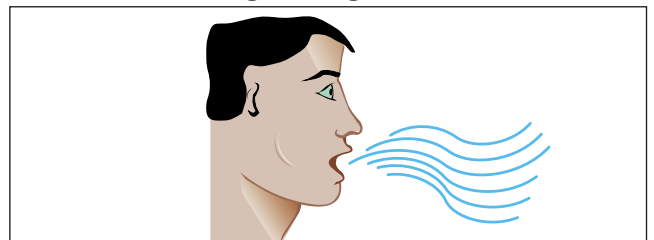

Leak Detection & Detectors

Refrigerant leaks must be found and rectified as a low refrigerant charge will cause system damage;

- Air and moisture can enter a system at the leak point and cause internal components to corrode.
- Compressor lubrication depends on refrigerant circulation.
- Refrigerant helps cool the compressor.

Leak detection methods

Visual leak detection

When a refrigerant leak occurs, it is common in some cases for the lubricant oil to escape with the refrigerant. The pressure of oil and encrusted dust around hose fittings, joints and components will indicate a leakage point.

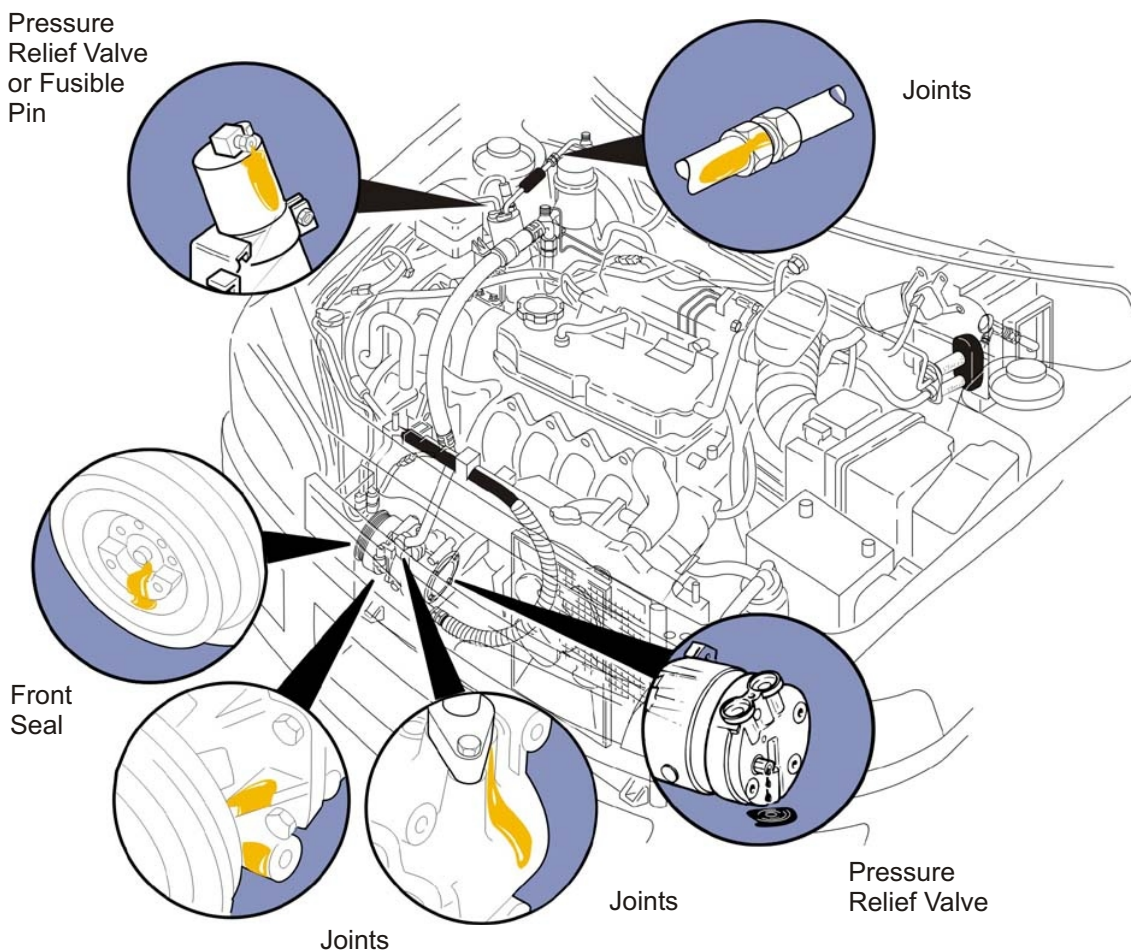

Leak Detection & Detectors

Soap solution

A mixture of dishwashing liquid and water applied around the A/C system pipes and fittings will form bubbles at the leakage points.

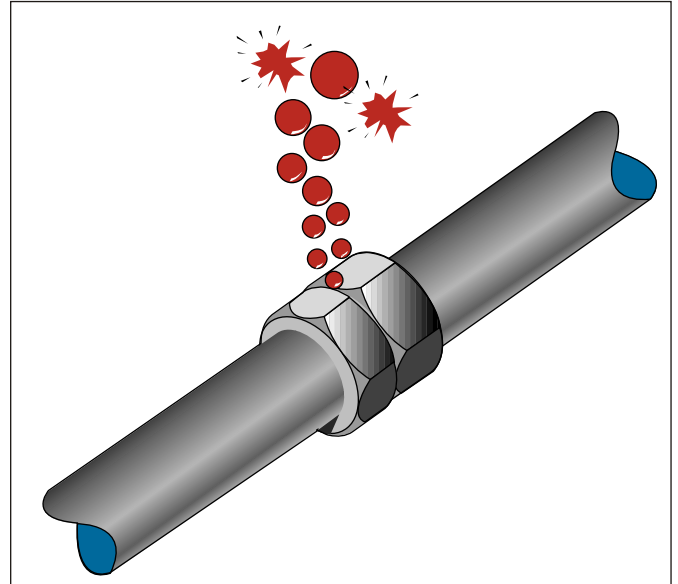

Electronic leak detector

These leak detectors operate in various ways. The most common being that when the unit is turned on, a low ticking sound can be heard and once the probe locates a leak, the ticking sound increases to a high pitched noise. This can be achieved by moving the sensing tip slowly around the underside of components and fittings at a distance of approximately 5 mm. DO NOT allow the sensing tip to contact components or fittings as false readings and tip damage will occur.

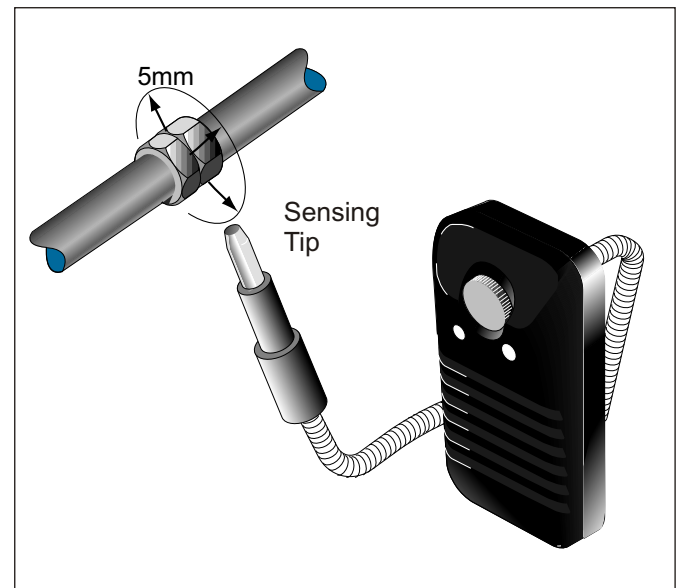

Important Notes:

- Only use a detector designed to sense the refrigerant in the A/C system you are testing;
- Always clean dirt and grime from the section you are testing otherwise the sensing tip will be clogged;
- Regularly check the detectors sensitivity by sampling a small leak of refrigerant from a charging port Schrader valve;
- Never allow the tip to contact the components being checked;
- Always check under fittings or components as refrigerant is heavier than air;
- Check for refrigerant leaks out of the wind;
- Check for refrigerant leaks with engine stopped.

Leak Detection & Detectors

Ultraviolet fluorescent system

A fluorescent colored dye is injected into the A/C system and allowed to circulate, then a specially designed ultraviolet lamp is passed over each component in the A/C system. If a leak is evident, the colored dye glows bright. This method is exceptionally good for pin pointing a small leak.

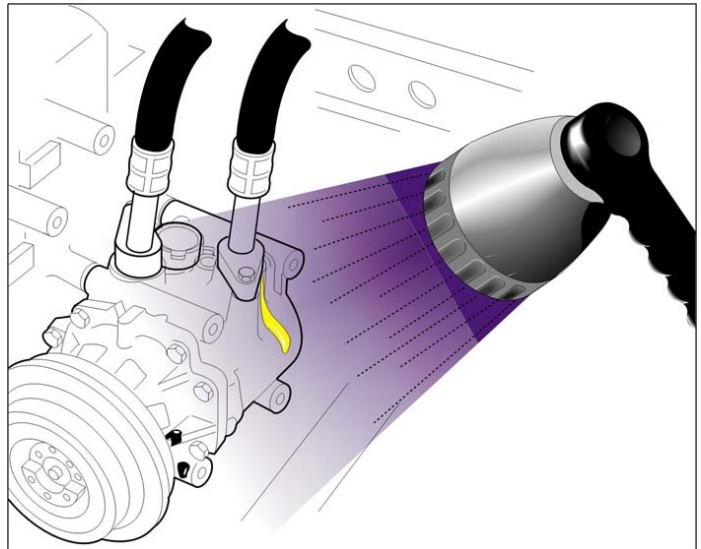

Important notes

- It is advisable to ask the customer to return in approximately one week time as the dye could take longer to emerge if the A/C system has a small leak.
- Check with the A/C manufacturer to see if these dyes are suitable, and will not damage the A/C system components, such as filter drier desiccant. Failure to do so could void the manufacturer warranty.
- Always check manufacturers recommendations prior to using this methods.

Lubrications

Component replacement

When replacing components, check the manufacturers recommendations on the quantity of oil to be added to the new components before installation. This is normally found in the particular vehicle workshop manual.

EXAMPLES of approximate quantities:

- Evaporator - 40cc*
- Filter drier - 25cc*
- Condenser - 30cc*
- Accumulator - 40cc*
- Hose blown - 50cc*
- Tubes - 20cc*

Compressor (new replacement)

Drain and measure the lubricating oil from removed compressor. Likewise, remove the oil from the new compressor, refill this new compressor with the same quantity of oil drained from the old compressor.

On compressors without inspection plugs, add oil to compressor through the discharge and suction ports, turn the compressor hub several times by hand to make sure no oil is trapped in the compressor chambers.

Use the new clean oil removed from the new compressor plus 10cc to allow for any internal oil.

Receiver Driver

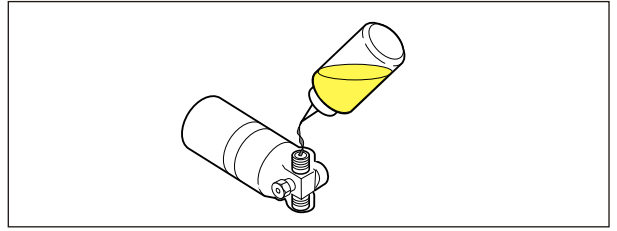

Compressor

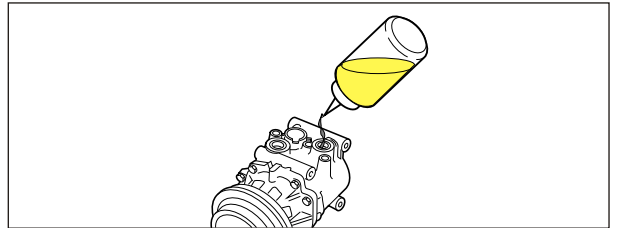

Hoses

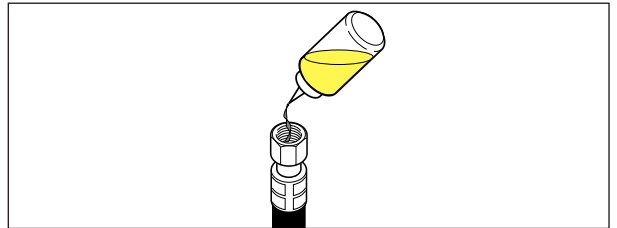

Condenser

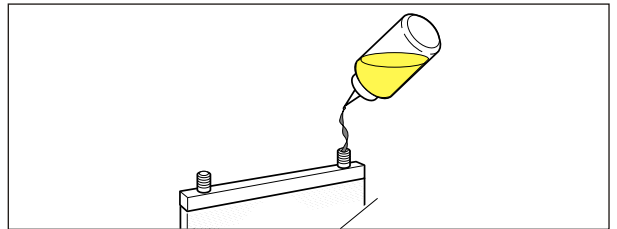

Removed Compressor

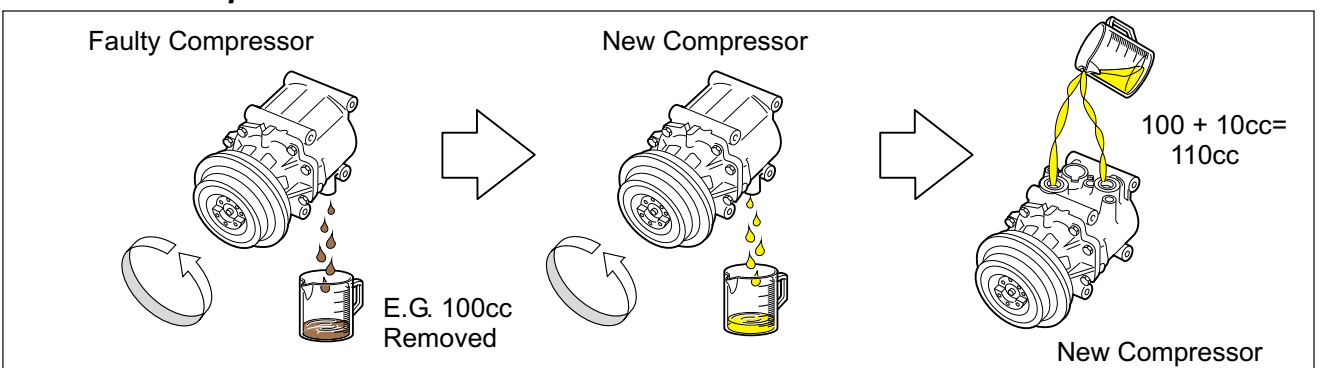

Flushing a contaminated system

If a seized or damaged compressor is to be replaced, inspecting of discharge hose interior is advised.

On inspecting the interior of the discharge hose, if particles or silvers of aluminium are found, flushing of the A/C system is required including a new filter drier.

We recommend flushing individual components or system sections with refrigerant R134a, this refrigerant should be collected via a recovering machine and can be used again. Components or tube connections (mostly self-made) will have to be used and flushing carried out with the refrigerant in liquid from i.e. the decanting cylinder turned upside down. Failure to flush a contaminated system will lead to blockage in the condenser filter drier or TX valve and possibly cause compressor damage.

After finishing flushing, blowing the system with dry nitrogen is recommended.

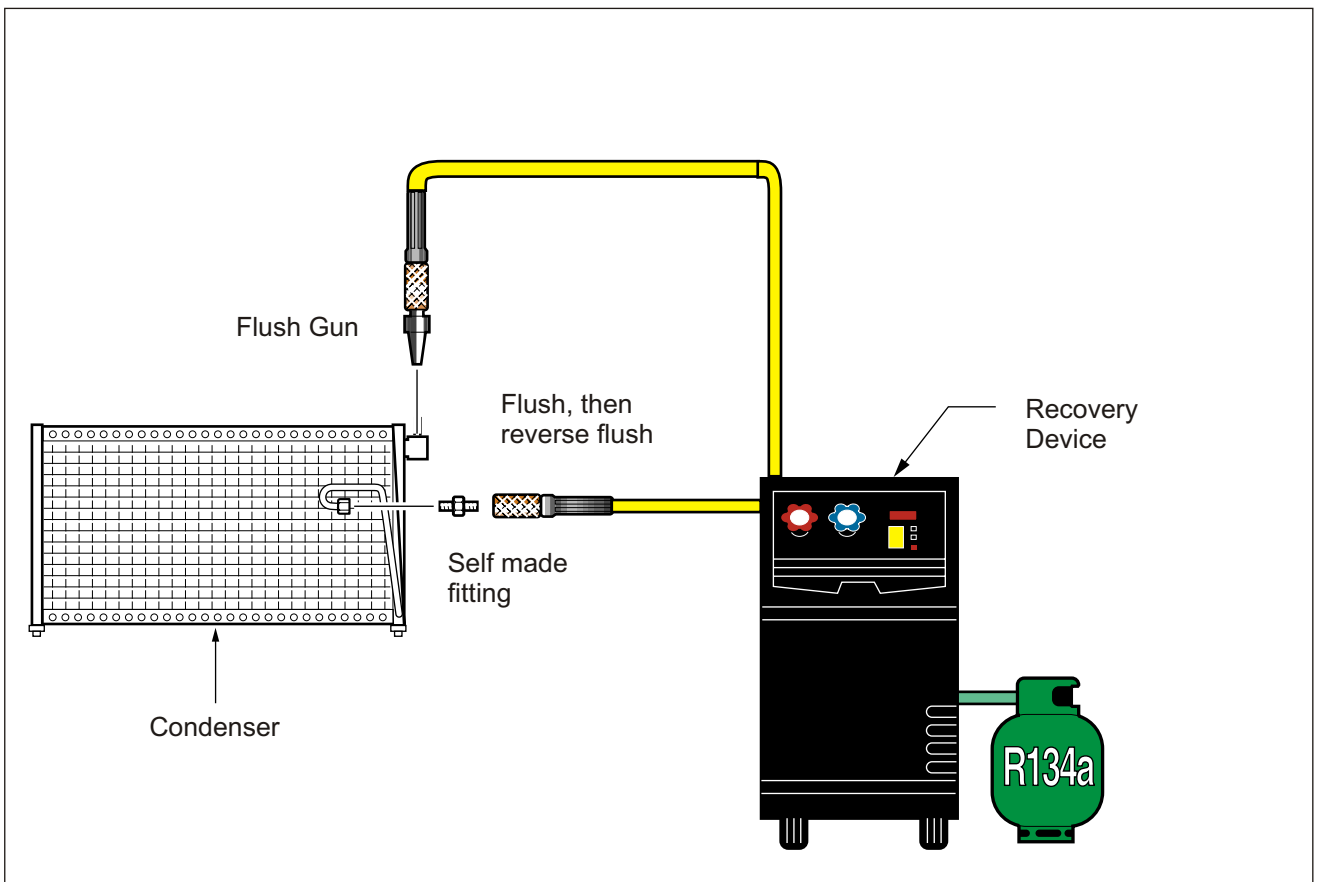

Preparations

Before servicing or diagnosing an A/C system there are preliminary checks that should take place. These include:

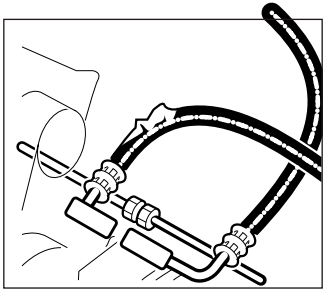

Checking for visual hose damage and chaffing

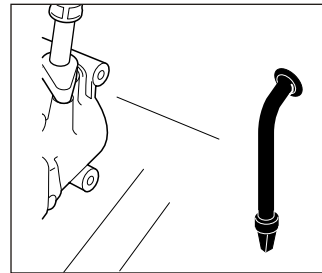

Compressor cycles on and off.
Evaporator drain hose not blocked.

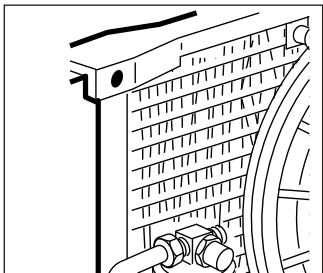

Ensure the condenser cooling fins are not blocked with obstructions such as insects, leaves or grass.

Condenser fan operates and runs in correct direction.

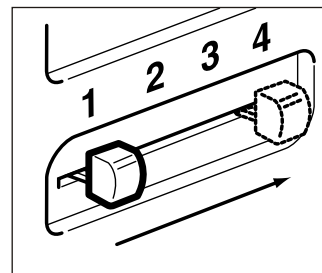

Heater turned off in the full cold mode position.

Blower fan has all speeds operational.

Air mix door fully closed.

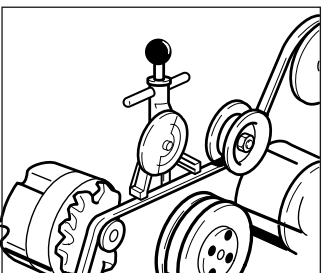

Inspect drive belts for correct tension and damage.

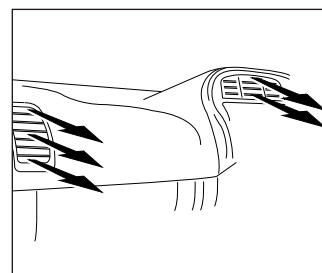

Dash vents open and close fully.

No air leaks between evaporator case and heater case.

Testing conditions / Preliminary steps

Performance testing (General)

- STEP 1.** Park vehicle in a shaded area. Take note of ambient temperature.
- STEP 2.** Open both front windows and engine hood.
- STEP 3.** Connect both high and low pressure service hose coupling valves to the system filling ports.
- STEP 4.** Open all dash louvers and adjust to the straight-ahead position.
- STEP 5.** Insert thermometer probe approximately 50 mm into the center vent louver.
- STEP 6.** Set the controls to:
Fresh air position;
Maximum cooling;
A/C on;
Highest blower speed.
- STEP 7.** Start engine, bring engine speed to 1700 RPM then allow pressure gauge needles to stabilize.
- STEP 8.** Take pressure and temperature readings. Compare this to the manufacturers performance charts found in appropriate workshop manuals.

NOTE: Only take pressure and temperature readings when the compressor is engaged.

As you can see from the above typical performance test, the A/C system is put under an increased load such as doors and engine hood open and high blower speed. If A/C system can perform to the manufacturers specifications under these loads, in normal driving situations with engine hood closed and possibly a lower blower speed, center vent temperatures will be much lower.

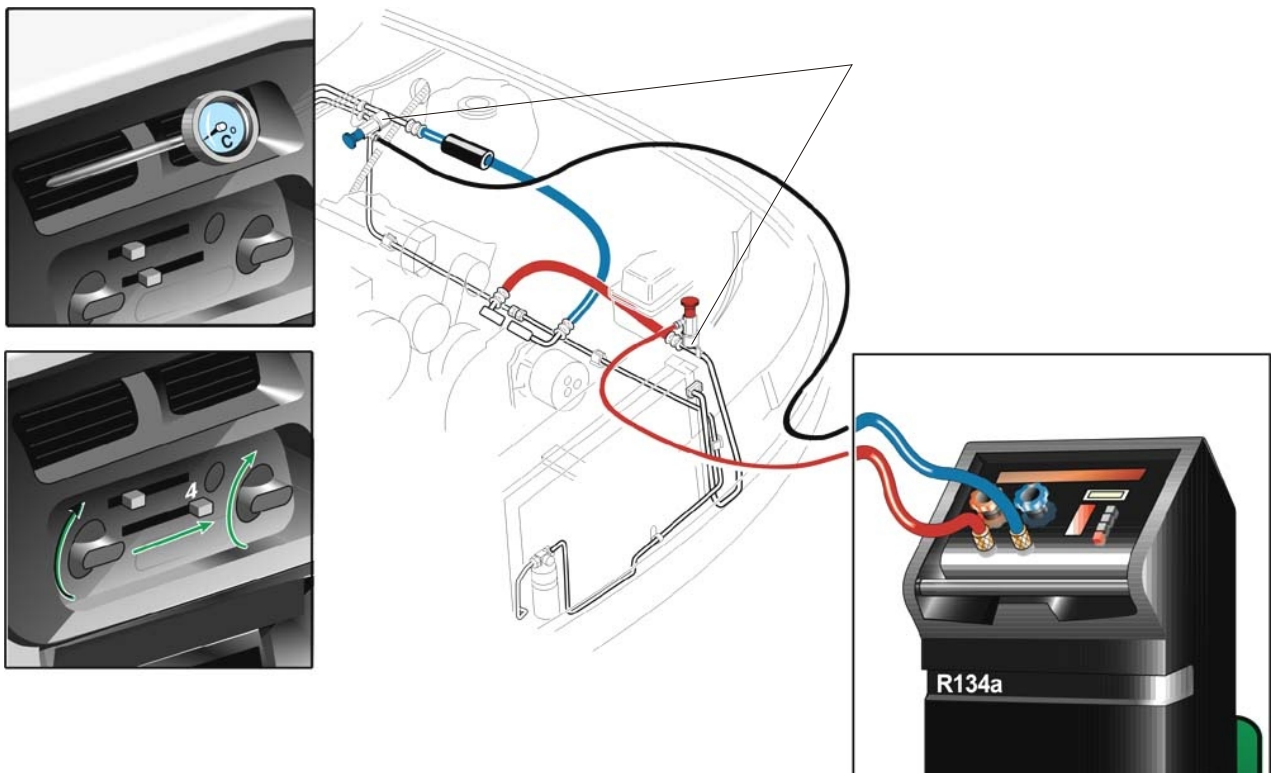

A/C performance check

Use a thermometer to check the temperature at the central vents, placing the thermometer probe as close as possible to the air outlet. Compare the average value to the table below.

Temperature table				
Temp. inside the vehicle (°C)	20	25	30	35
Air outlet temp. at central vents (C)	4-10	5-12	6-13	8-14

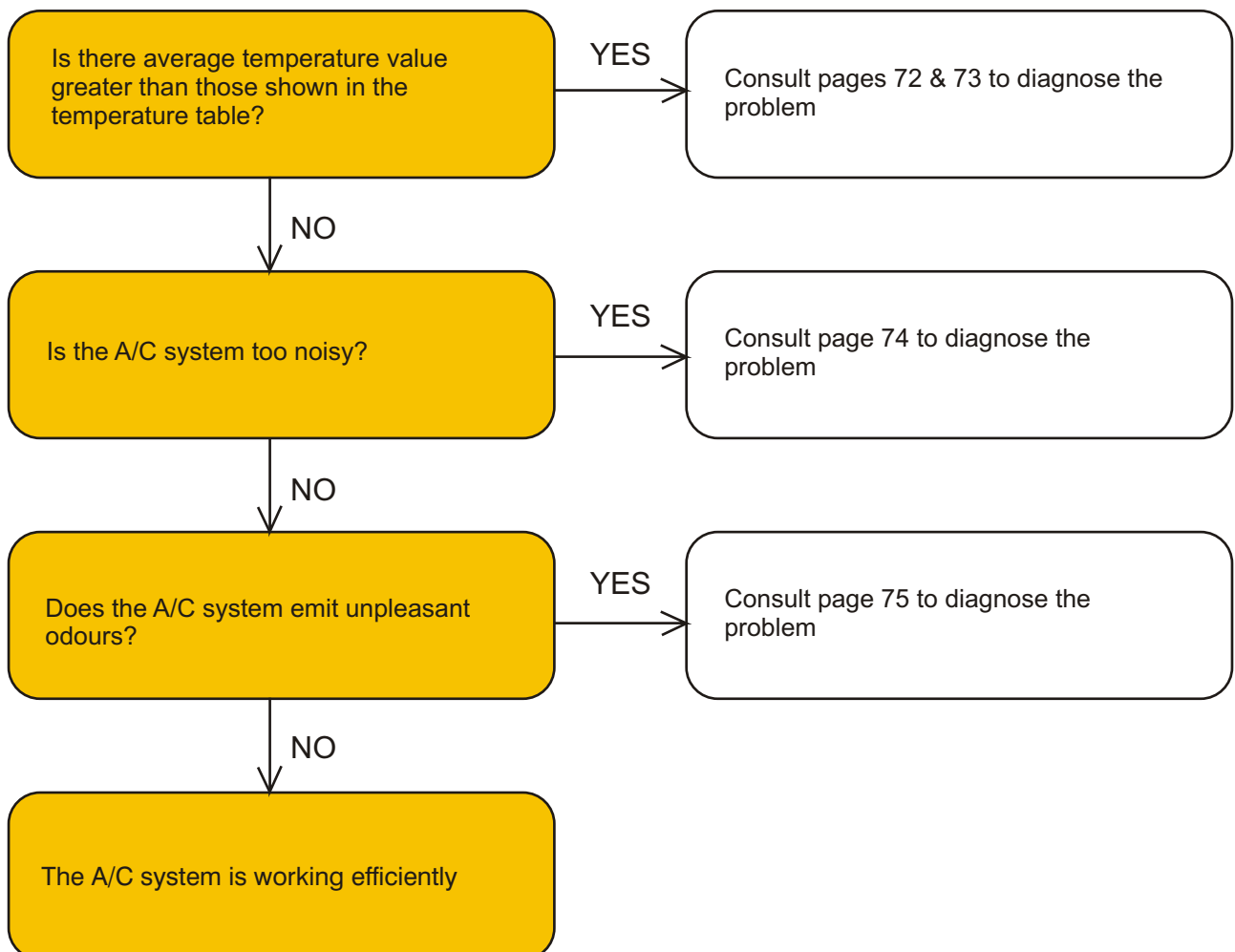

A/C performance check

Pressure gauges

An accurate diagnosis and determination of air conditioning system function and more importantly, malfunction, depend largely upon the ability of the technician to interpret gauge pressure reading. The importance of a refrigeration technicians manifold and gauge set is often compared to that of a doctor's stethoscope.

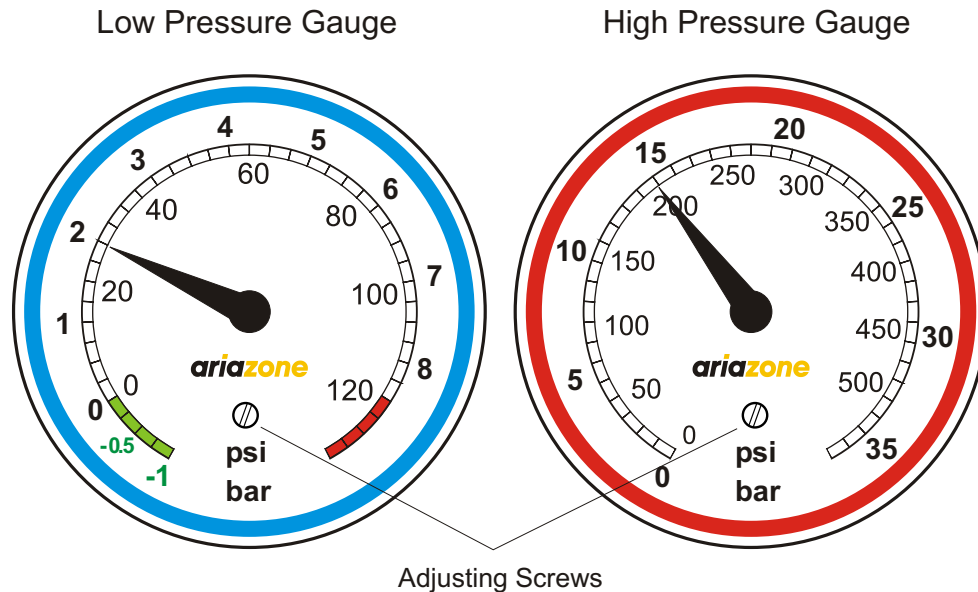

An improper gauge reading will relate to a specific problem. More than one problem may be associated with particular gauge reading, however. A system operating normally will have a low-side gauge pressure reading that corresponds with the temperature of the liquid refrigerant as it becomes a vapor while removing heat from the air flowing over the evaporator coil surface. The high-side gauge readings should correspond with the temperature of the vapor as it becomes a liquid while giving up its heat to the ambient air flowing through the condenser.

Any deviation from ambient dependant normal gauge readings, other than slight, indicates a malfunction. This malfunction, if within the system, may be caused by a faulty control device, a restriction, or defective component. It should be noted that improper mounting or location of components in a newly installed system may affect system performance. The vehicle engine may also affect system performance and will be note as abnormal gauge readings.

Pressure gauge pre check

Always inspect pressure gauges to ensure the needles rest as zero on both low and high sides on atmospheric pressure. If the needle(s) do not rest on zero, remove the hoses, open both taps, detach the dial face and gently turn the adjustable screw until the needle(s) rest on zero. Reconnect hoses and close taps.

A/C system performance check

Pressure gauges readings in normal condition

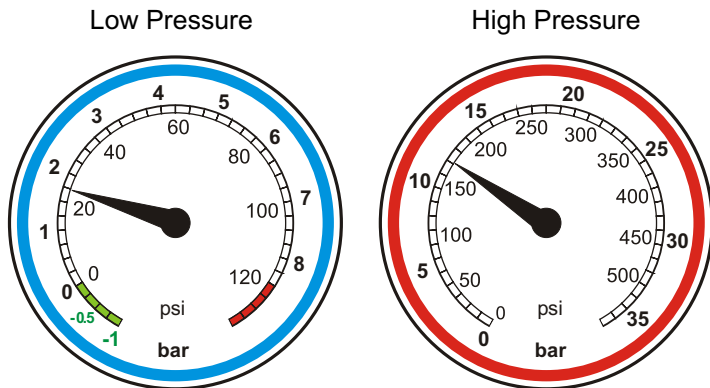

Gauges shows normal operation of A/C system.

If the pressure readings to the ambient temperatures are different to these, then the system is probably defective.

Note: Pressure gauge readings (low & high) depends on outside temperature.

1. Suction Pressure Vs Ambient Temperature

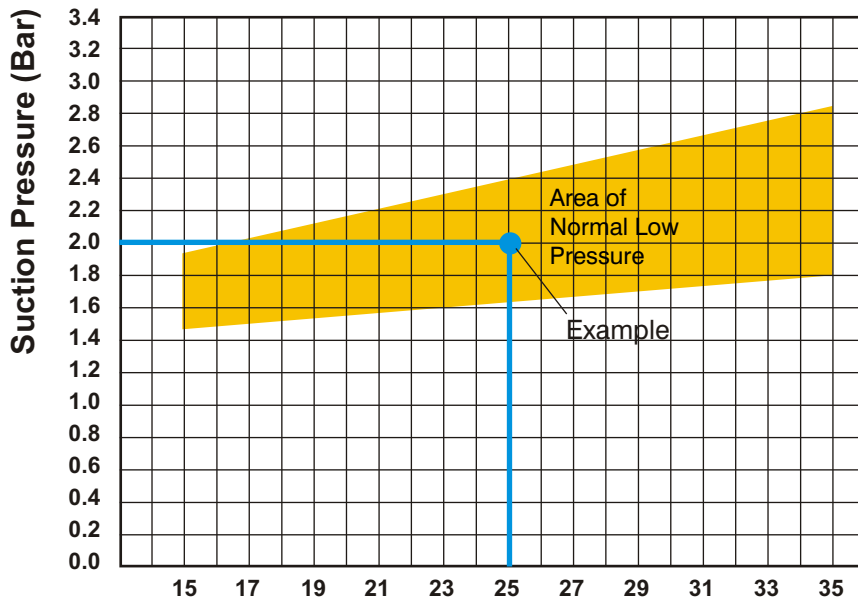

Example:

The outside temperature is 25 °C. The suction pressure we have measured is 2 bar.

The graph shows that the point is in the area of normal pressure.

2. Discharge Pressure Vs Ambient Temperature

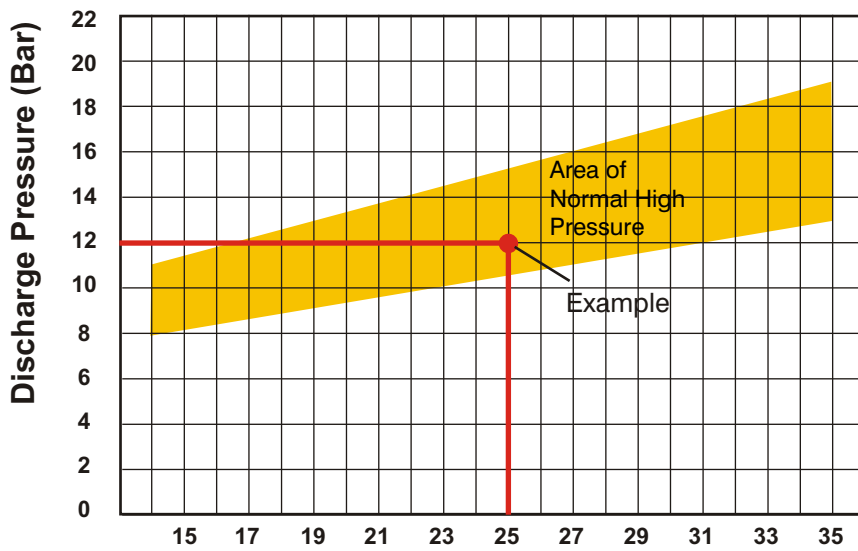

Example:

The outside temperature is 25 °C. The discharge pressure we have measured is 12 bar.

The graph shows that the point is in the area of normal pressure.

Faulty performance of A/C system

As we have mentioned before, correct pressure gauges reading may show particular problem or associate to a possible problems.

Note: (F) fixed displacement compressor, (V) variable displacement compressor

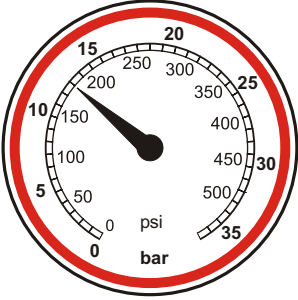
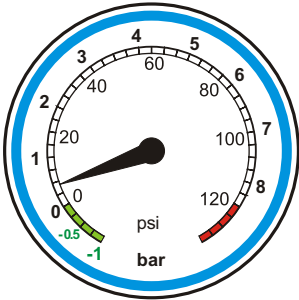
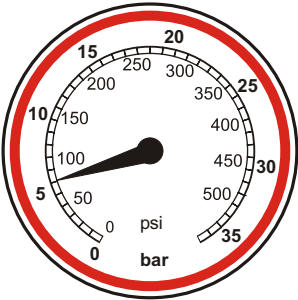
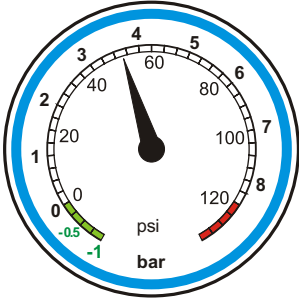
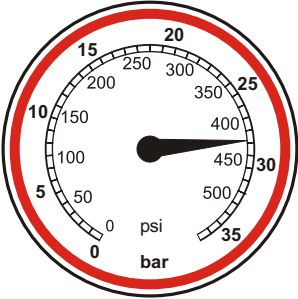
Pressure Gauges Reading		Probable Causes
<p>Low pressure</p>  <p>Normal</p>	<p>High pressure</p>  <p>Normal</p>	<p>Pressure readings are normal, A/C system is not cooling.</p> <ul style="list-style-type: none"> - Warm air infiltrated into the evaporating unit or passenger compartment. - Warm water infiltrated in the heater. - Ice on evaporator core.
<p>Low pressure</p>  <p>Normal or Low</p>	<p>High pressure</p>  <p>Low</p>	<ul style="list-style-type: none"> - Normal situation if ambient temperature is very low. - Too little refrigerant quantity, 70-75% less. check for leaks. - (V) Expansion valve stuck partially closed or blocked - (V) Clogging in the H.P. or L.P. branch between filter and evaporator. - Blockage in the H.P. branch between compressor and condenser-filter hose, but before the H.P. reading point.
<p>Low pressure</p>  <p>High or Normal</p>	<p>High pressure</p>  <p>High</p>	<ul style="list-style-type: none"> - Normal situation if ambient temperature is very high. - Excess refrigerant charge, 30-5% more. - Condenser overheated. - Air present in the A/C system. - (V) Compressor displacement regulator valve defective. - Blockage in the H.P. branch between compressor and condenser filter hose, but after the H.P. reading point.

Faulty performance of A/C system

Note: (F) fixed displacement compressor, (V) variable displacement compressor

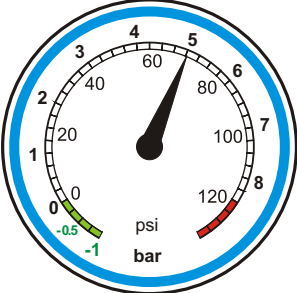
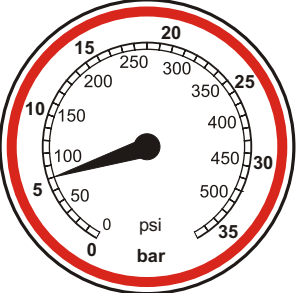
Pressure Gauges Reading		Probable Causes
<p>Low pressure</p> 	<p>High pressure</p> 	<ul style="list-style-type: none"> - Compressor belt jumped. Probably caused by misalignment of the pulleys (see page 74). - Electric clutch of the compressor not engaged. - Compressor damaged. - (V) Compressor displacement regulator valve defective.

L.P. approximately equal to H.P.

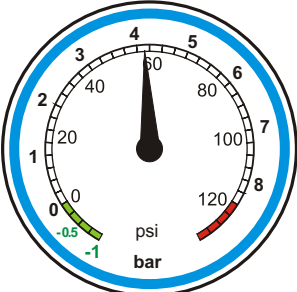
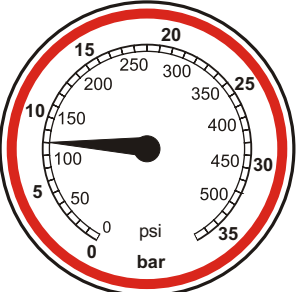
Pressure Gauges Reading		Probable Causes
<p>Low pressure</p> 	<p>High pressure</p> 	<ul style="list-style-type: none"> - Suction and drainage hoses reversed on compressor. - Electric clutch of the compressor not engaged. - Expansion valve stuck open. If the compressor is “variable displacement type”, the low pressure has small but fast oscillations. - (V) Compressor displacement regulator valve incorrectly set or defective - Compressor damaged

High

Normal or Low

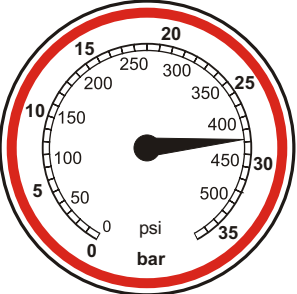
Pressure Gauges Reading		Probable Causes
<p>Low pressure</p> 	<p>High pressure</p> 	<ul style="list-style-type: none"> - Filter saturated with moisture - (V) Compressor displacement regulator valve stuck at maximum displacement. - (F) Blockage in H.P. or L.P. branch between filter and evaporator.

Low

High or Normal

A/C system is noisy

The noise heard when the A/C system is first turned on is not due to a defect. In the event of persistent noise, check for the presence of one of the following malfunction causes and apply the corresponding solution.

Cause	Solution
1. Belt worn or slipped	1. Check the wear and tension of the belt.
2. Belt idler pulley is noisy	2. Replace it.
3. Electric clutch plate slipping	3. Make sure that the distance between the compressor pulley and electric clutch is 0.3-0.5mm.
4. Vibration and resonance of the compressor support plate.	4. Make sure the bolts are tight and the plate is properly positioned.
5. Expansion valve “whistles”.	5. If the noise persists, replace the valve.

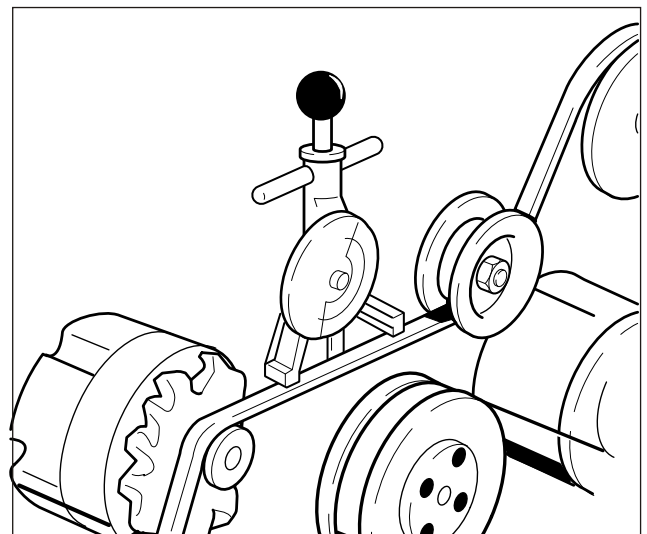
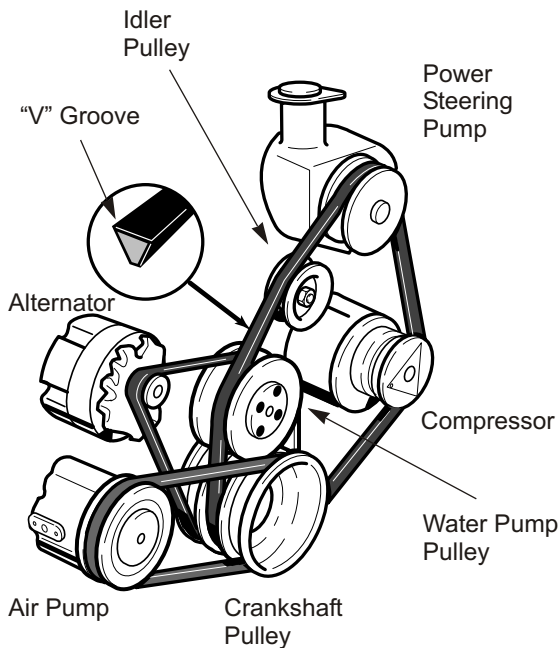

In The following instances, a few defective components of the A/C system create an incorrect inlet and outlet pressure. This phenomenon causes noise in the compressor that is actually due to one of the causes listed below and NOT to the compressor itself.

- Incorrect amount of refrigerant (30-35% more or 70-75% less).
- Expansion valve stuck shut or blocked.
- Compressor displacement regular valve defective (for variable-displacement compressors only).
- Clogging in the A/C system circuit
- Filter saturated with moisture.

A/C system emits unpleasant odours

Under certain conditions, moulds and bacteria (normally present in the air) may form on the surface of the evaporator core, causing an unpleasant odour inside the vehicle.

- Use an antibacterial product to treat the evaporator.
- Advise the customer to turn off the A/C system a few minutes before shutting off the vehicle, leaving the blower fan running (this will dry the evaporator core from the moisture that encourages bacteria growth).

The condenser doesn't dissipate enough heat

Cause	Solution
1. Air flow blocked by dirt accumulated on the heat exchangers; water radiator, condenser.	1. Clean the radiator and condenser thoroughly.
2. The pressure switch or water temperature bulb are not tripped at the correct pressure and temperature levels.	2. Cut out the controls using the appropriate electrical connection. Replace the defective part if necessary.
3. The electric fan does not work	3. Power the electric fan directly. replace if it still does not work.
4. Incorrect functioning by the electric fan (incorrect rotation direction).	4. The fan must be "suction" type when placed between the heat exchangers and the engine, and "blowing" type if placed between the heat exchangers and outside air intake.
5. Engine water overheated	5. Make sure the original engine cooling system is working properly.
6. Condenser not positioned correctly.	6. Make sure that the distance between the radiator and condenser is 15-20mm, if present the air ducts must be correctly positioned.

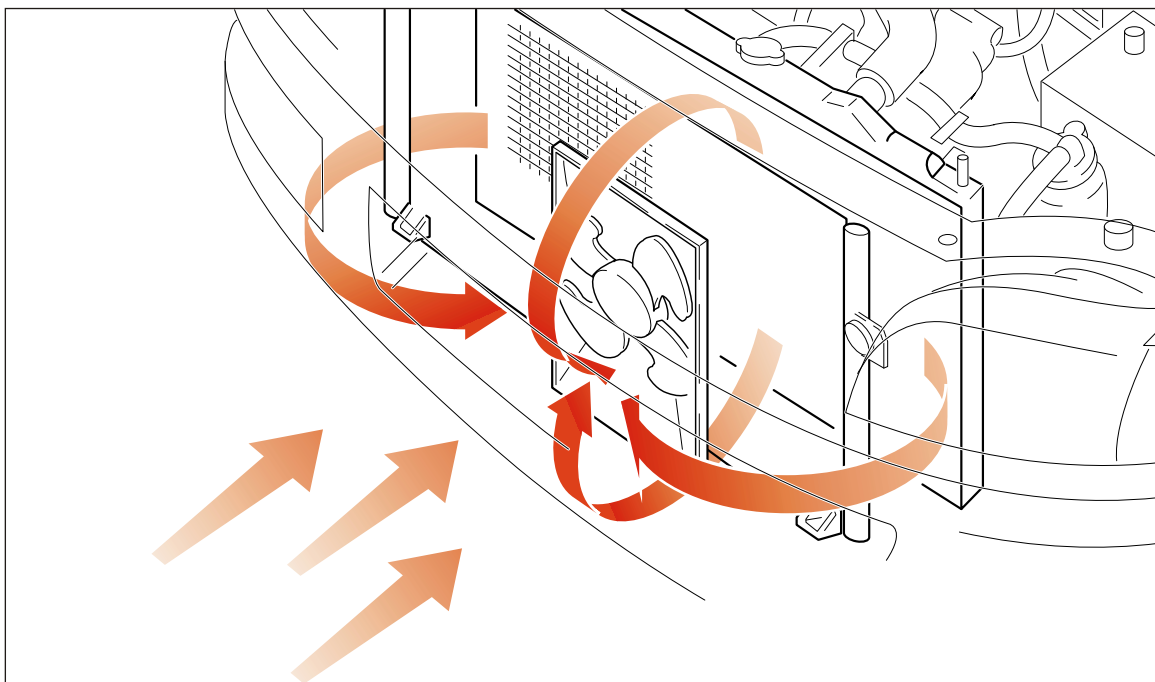

Incorrect refrigerant amount

Air or incondensable gases or moisture in the A/C system

Cause

1. Incorrect refrigerant amount (30-35% excessive or 70-75% lack).
2. Contaminated refrigerant.
3. Filter saturated with moisture.

Solution

1. Recover refrigerant from the A/C system.
2. Replace the A/C filter (if filter is saturated with moisture).
3. Evacuate the incondensable gases and moisture from the A/C system. Run the vacuum pump for at least 30 minutes.
4. Check the vacuum seal using a pressure gauge control.
5. Restore the recommended amount of refrigerant to the system as well as any oil recovered together with the refrigerant.

Compressor displacement regulator valve defective (only for variable-displacement compressors)

Cause

1. Valve blocked by impurities (the evaporator tends to freeze)
2. Regulator springs of the valve improperly set

Solution

1. Recover refrigerant from A/C system.
2. Replace the displacement regulator valve located in the compressor rear cover.
3. Evacuate the incondensable gases and moisture from the A/C system by letting the vacuum pump run at least 15 minutes.
4. Restore the recommended amount of refrigerant to the system as well as any oil recovered together with the refrigerant.

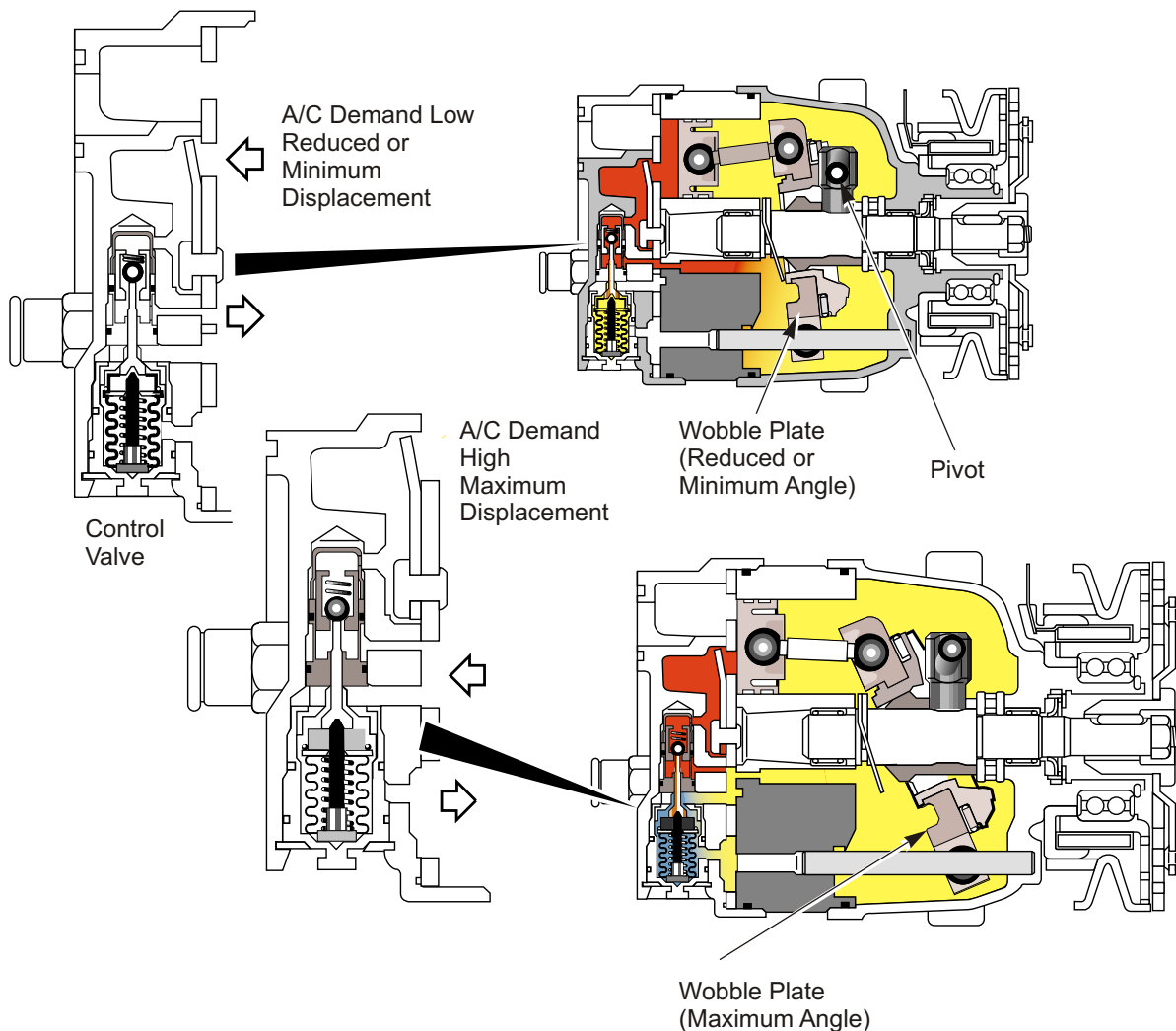

Expansion Valve Defective

Cause

1. Thermostatic capillary of the valve is defective.
2. Mechanics of the valve are jammed.

Solution

1. Recover refrigerant from the A/C system.
2. Replace the expansion valve.
3. Evacuate the incondensable gases and moisture from the A/C system by letting the vacuum pump run for at least 15 minutes.
4. Restore the recommended amount of refrigerant to the system as well as any oil recovered together with the refrigerant.

Expansion Valve Diagnosis

If when carrying out pressure gauge diagnosis it is found the TX valve is at fault, ie.

Jammed fully open - high/low pressure to high, or

Jammed fully closed - low pressure zero to a vacuum;

then follow the resting procedure below.

Testing

- a. Remove the evaporator case and dismantle,
- b. Detach the TX valve pressure compensating tube and temperature sensing bulb from the evaporator outlet side; **Mark** the area on the outlet tube where the sensing bulb is clamped when replacing a TX valve. This sensing bulb **must** be fitted in exactly the same position.

Opening Test: Warm the temperature sensing bulb by hand, the TX valve should now be fully open. This can be verified by blowing through the valve.

Closing Test: Into a container of water and crushed ice, place the temperature sensing bulb and gently stir, the TX valve should now be fully closed. This can be verified by blowing through the valve.

if any of the above tests fail, replace the TX valve with the correct type i.e. (tonnage and super heat). ensure new "O" rings are used and that the temperature bulb is covered with insulating material to ensure no false temperature readings are obtained.

Caution - when bending the temperature sensing tube to fit, care must be taken not to break it as this tube is hollow and contains refrigerant.

Opening test

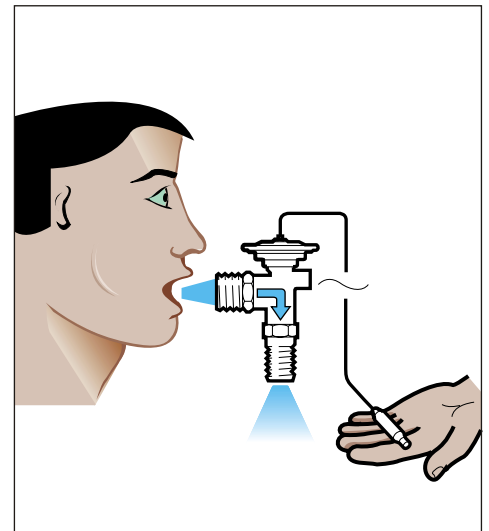

Closing test

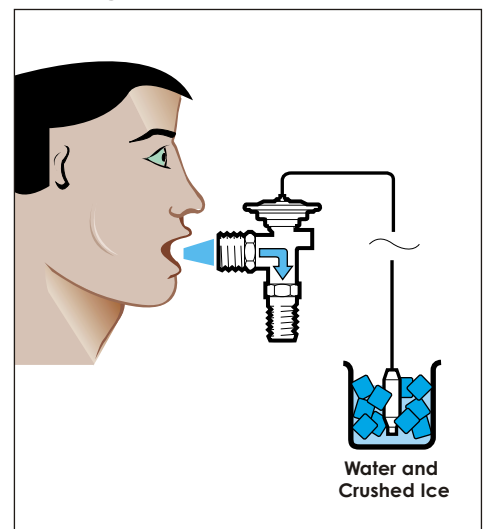

The Electric Compressor Clutch Slips or Does Not Engage

Note: For valves equipped with automatic control (ECC), go to self-diagnostic or software control.

Cause	Solution
1. Shortage of refrigerant (70-75% lack)	1. Search for the refrigerant leak
2. Electric clutch coil de-energized or intermittent energized	2. Disconnect the electrical clutch wire from the electrical system and connect it to the positive pole of the battery using a 7.5A fuse. If the clutch does not engage, it must be replaced. If it does engage, check the pressure switch, thermostat, A/C control switch, and miscellaneous electrical connections.
3. Incorrect distance between compressor pulleys and electric clutch plate.	3. The distance must be between 0.3-0.5mm

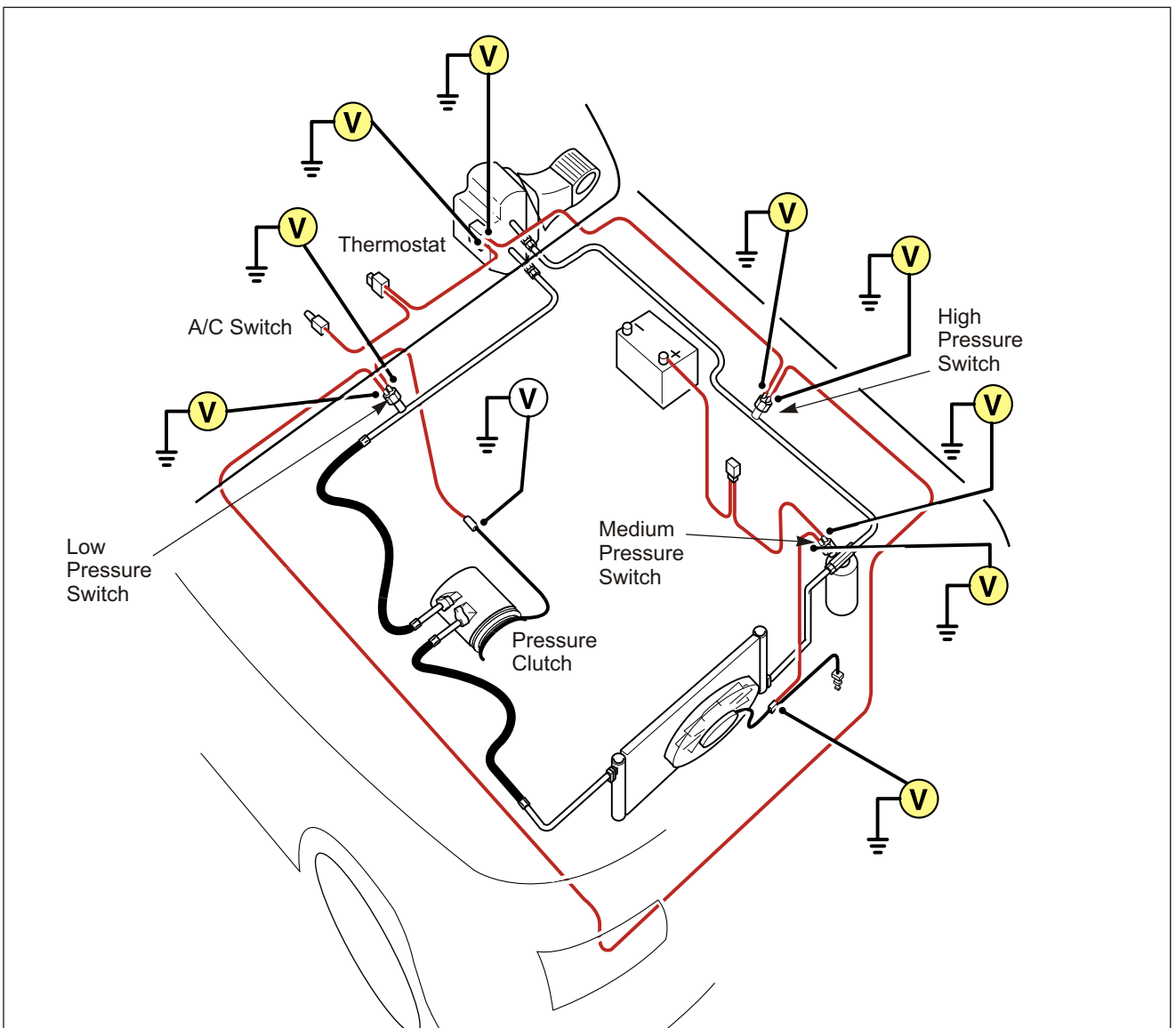

Ice on the Evaporator Core

Cause	Solution
1. Malfunction by the thermostat or “no-frost” probe (if present)	1. Make sure the electrical connection of the thermostat or of “no-frost” probe is in good condition, and that the sensor is properly positioned. Replace any defective parts as needed.
2. Malfunction by the blower fan	2. With the A/C system running, at least the first ventilation speed must work. Otherwise, make sure the electrical system is properly connected.
3. Compressor displacement regulator valve is defective (only for variable displacement compressors)	3. Check the operation of the compressor displacement regulator valve.

Note:

- This may occur even after a few minutes of operation, causing a progressive drop in the air flow at the vents.
- For valves equipped with automatic control (ECC), go to self-diagnostic or software control.

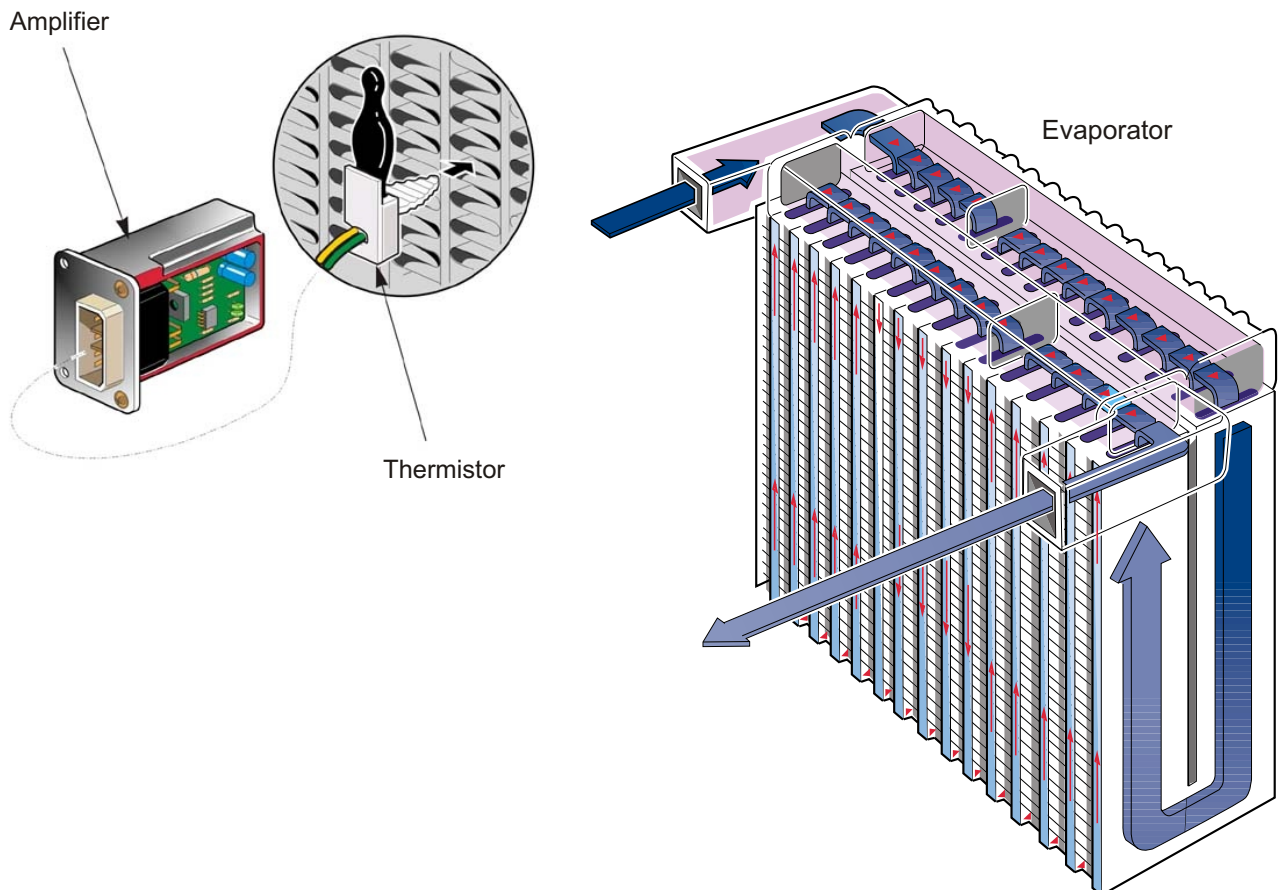

Compressor Damaged

Cause

1. Valves bent
2. Seizing

Solution

1. Recover refrigerant from A/C system.
2. Replace the compressor from A/C system.
3. If the compressor is seized, flush the A/C system using a specific product and replace the dehydrator filter.
4. Install a new compressor.
5. Evacuate the incondensable gases and moisture from the A/C system by letting the vacuum pump run at least 30 minutes.
6. Restore the recommended amount of refrigerant to the system as well as any oil recovered together with the refrigerant.

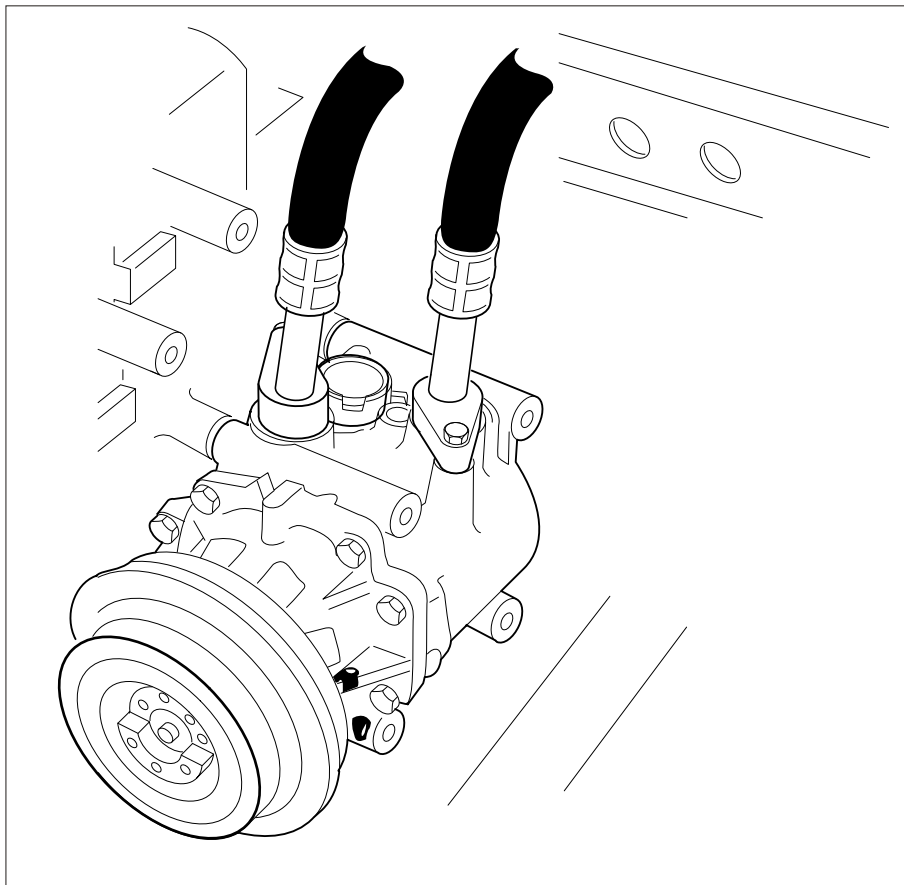

Hot Air Infiltrated in the Passenger Compartment Hot Water Infiltrated in the Heater

Cause	Solution
1. The water valve of the heater (if present) does not close properly.	1. Check the lever mechanisms and/or valve control motor. Cut out the heater if necessary.
2. The air mixing and/or re-circulating flaps are not perfectly sealed.	2. Check the lever mechanisms and/or valve control motors.
3. Sealing of the evaporator unit poorly airtight	3. Make sure the evaporator unit is tightly sealed and the couplings with the original heater are correct, to prevent warm air from infiltration from outside.

Air Flow during Maximum Hot

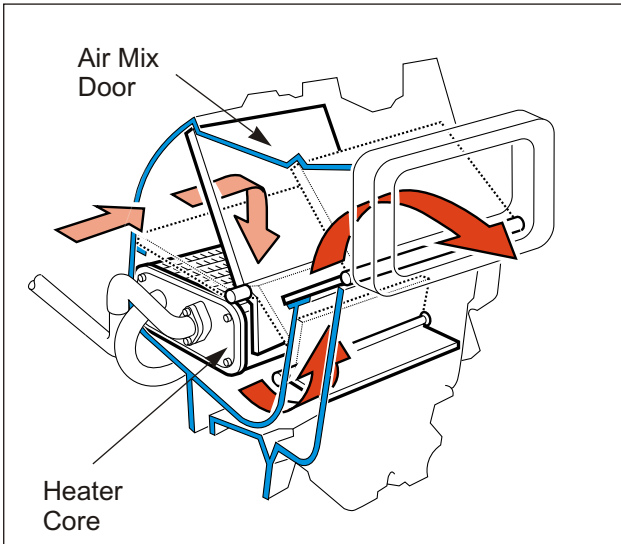

Air Flow during Maximum Cold

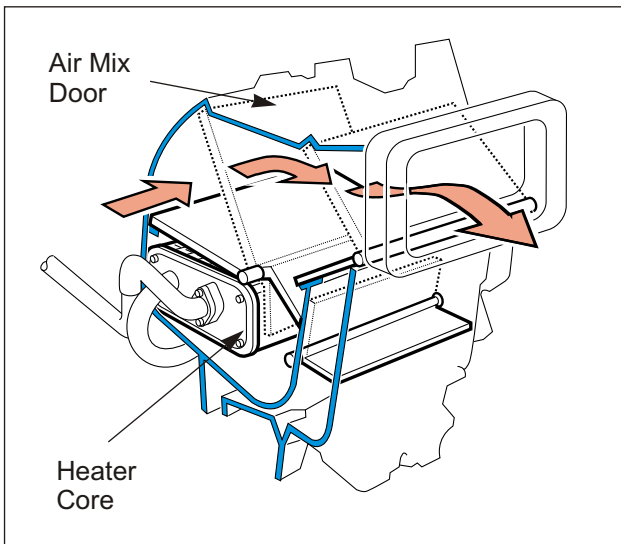

Blockage in the A/C system circuit

A very useful diagnostic aid is the “Feel Test”. As the test implies it is a matter of quite simply feeling tubes and components for temperature drops, indicating possible blockage location.

By this stage you would be aware of what side of the A/C system should be hot and what side should be cold. But what also happens with the pressure gauge reading, sometimes they don’t make sense.

The location of the charging ports in relation to the A/C system MUST be taken into consideration. A pressure gauge reading could be high or low depending on what side of the charge port the blockage is located. Use the “Feel Test” as well as the pressure gauges readings.

Normal System

HIGH SIDE - Hot
LOW SIDE - Cold

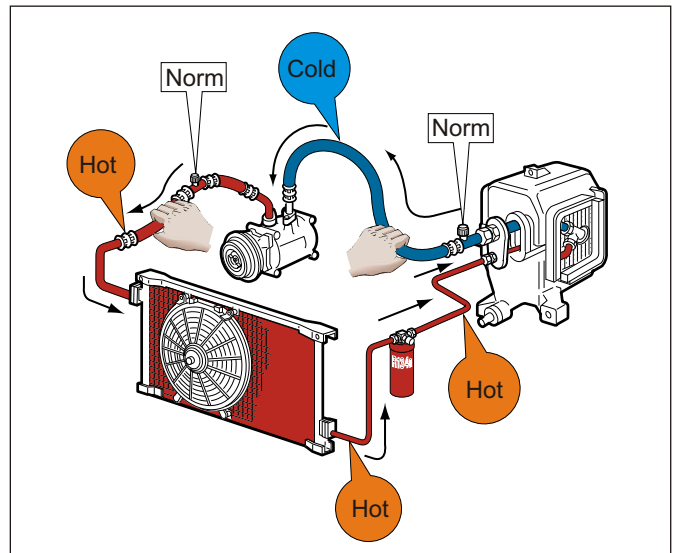

Blockage - High Side (after charge port)

High side pressure - High
Low side pressure - Low to normal

- High pressure switch will not deactivate the A/C system, low pressure switch might;
- Compressor noisy;
- High Side hose very hot before blockage;
- High side hose very cool to warm after blockage.

⊗ Indicates Blockage

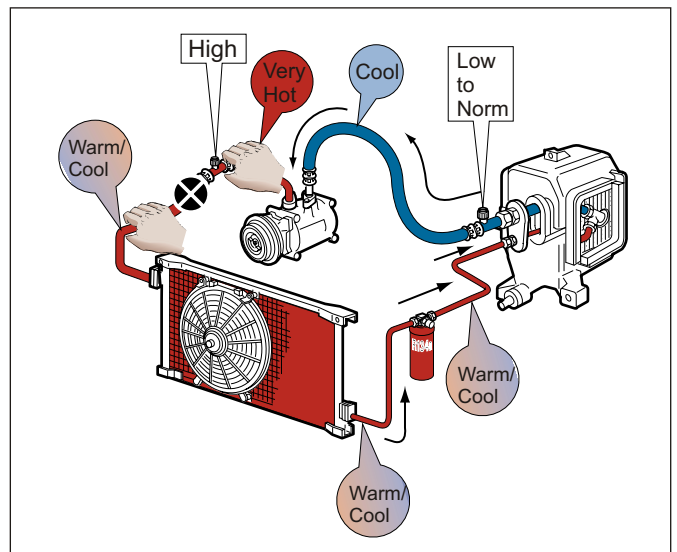

Blockage in the A/C system circuit

Blockage - High Side (before charge port)

High side pressure - Low
Low side pressure - Low to normal

- High pressure switch will not deactivate the A/C system, low pressure switch might;
- Compressor noisy;
- High Side hose very hot before blockage;
- High side hose very cool to warm after blockage.

⊗ Indicates Blockage

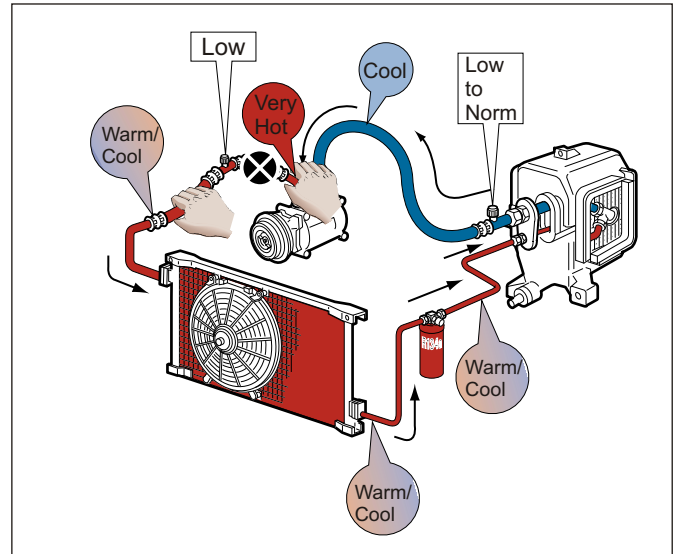

Blockage - Low Side (after charge port)

High side pressure - Low
Low side pressure - High

- Low pressure switch will deactivate the A/C system;
- Frosting of the low side hose/fittings before the blockage.

⊗ Indicates Blockage

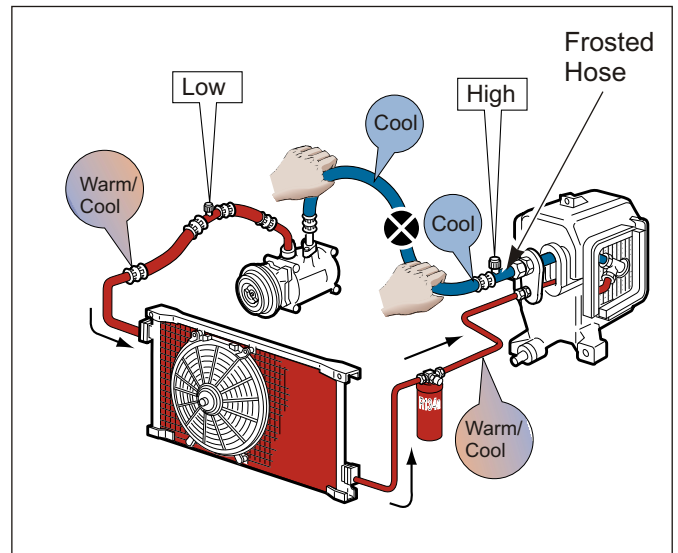

Blockage - Low Side (after charge port)

High side pressure - Low
Low side pressure - Low to vacuum

- Low pressure switch will deactivate the A/C system;
- Frosting of the low side hose/fittings before the blockage.

⊗ Indicates Blockage

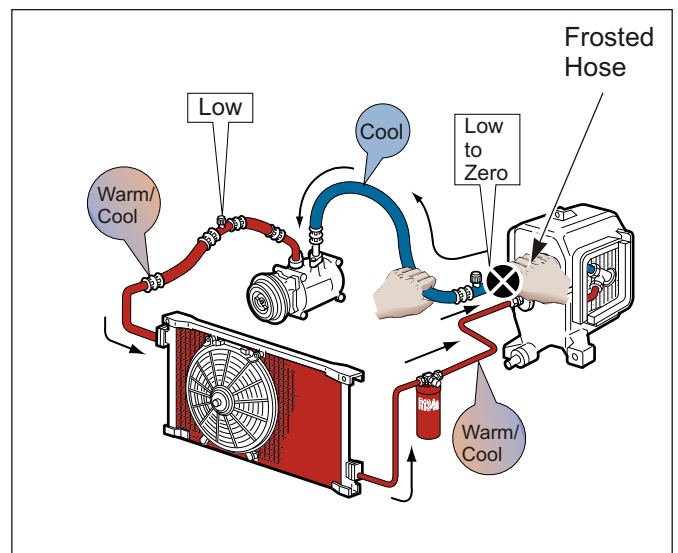

Blockage in the A/C system circuit

Blockage - Orifice Tube (Orifice Tube system)

High side pressure - Low
Low side pressure - Low to vacuum

- Low pressure switch will deactivate the A/C system;
- Frosting of the tube after the orifice tube.

⊗ Indicates Blockage

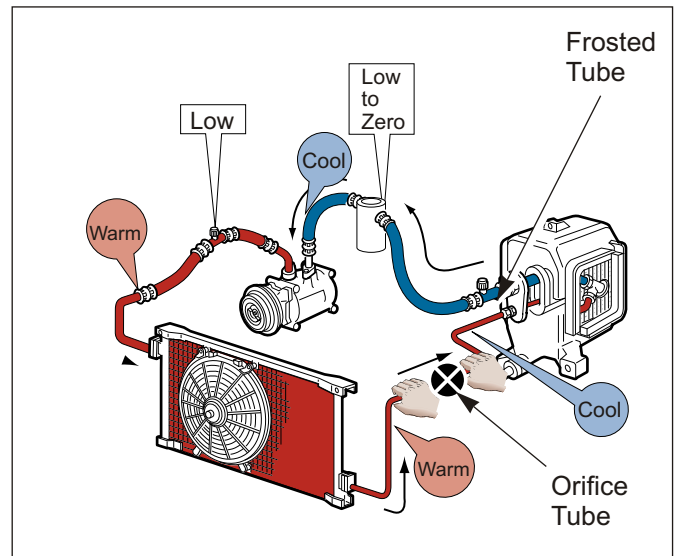

Blockage - Receiver Drier

High side pressure - High
Low side pressure - Low to vacuum

- Low pressure switch will deactivate the A/C system;
- If the blockage is in the receiver drier itself, the outlet tube will be frosted

⊗ Indicates Blockage

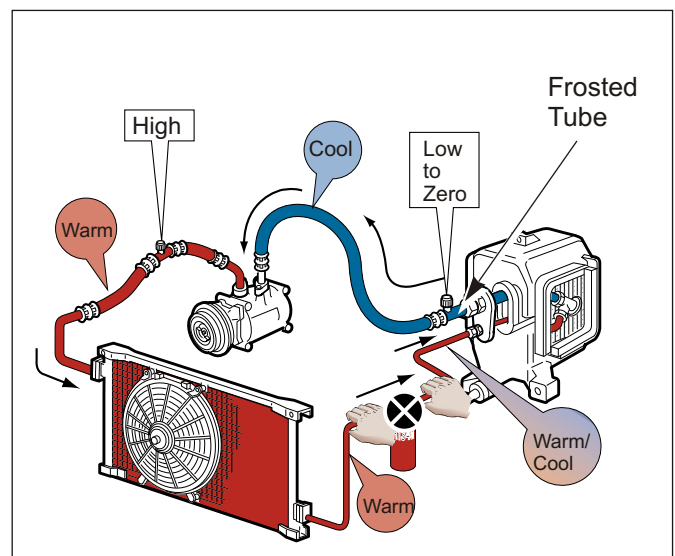

Checking refrigerant charge (orifice tube system)

Run the A/C system, place one hand at the outlet side of the orifice tube and one hand on top of the accumulator.

If the temperature of the accumulator is higher than the temperature after the orifice tube, then the refrigerant charge is not to specification. Add 150g and recheck.

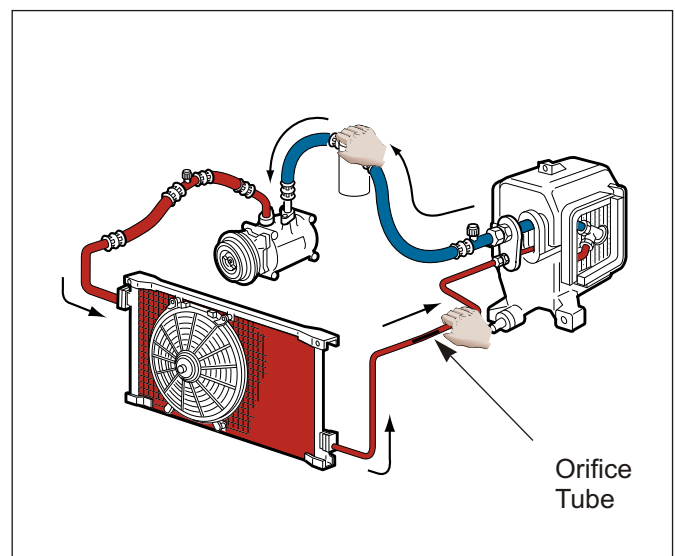

Blockage in the A/C system circuit

Blockage - Condenser

A change of state, where high pressure vapour forms into a high pressure liquid during the movement through the condenser, takes place within approximately the first 1/3 of the condenser. With this change of state a slight (depending on ambient temperature change) takes place.

Using your finger, follow the tube(s) of the condenser (avoid burning your skin), you can feel where the change of state takes place. This change will however be quite subtle. But if you feel the difference in temperature before approximately the first 1/3, a blockage may be present.

With the parallel flow design condenser, refrigerant flows through more than one tube so the possibility exists that the condenser will operate sufficiently in lower ambient. But when the ambience increases and greater refrigerant flow is required, a blockage in one tube will cause problems such as poor performance and excessive discharge pressures.

