

## **CHAPTER 8**

### **PROJECT TIME-COST TRADE-OFF**

In the previous chapters, duration of activities discussed as either fixed or random numbers with known characteristics. However, activity durations can often vary depending upon the type and amount of resources that are applied. Assigning more workers to a particular activity will normally result in a shorter duration. Greater speed may result in higher costs and lower quality, however. In this section, we shall consider the impacts of time and cost trade-offs in activities.

Reducing both construction projects' cost and time is critical in today's market-driven economy. This relationship between construction projects' time and cost is called time-cost trade-off decisions, which has been investigated extensively in the construction management literature. Time-cost trade-off decisions are complex and require selection of appropriate construction method for each project task. Time-cost trade-off, in fact, is an important management tool fo overcoming one of the critical path method limitations of being unable to bring the project schedule to a specified duration.

#### **8.1 Time-Cost Trade-Off**

The objective of the time-cost trade-off analysis is to reduce the original project duration, determined form the critical path analysis, to meet a specific deadline, with the least cost. In addition to that it might be necessary to finish the project in a specific time to:

- Finish the project in a predefined deadline date.
- Recover early delays.
- Avoid liquidated damages.
- Free key resources early for other projects.

- Avoid adverse weather conditions that might affect productivity.
- Receive an early completion-bonus.
- Improve project cash flow

Reducing project duration can be done by adjusting overlaps between activities or by reducing activities' duration. What is the reason for an increase in direct cost as the activity duration is reduced? A simple case arises in the use of overtime work. By scheduling weekend or evening work, the completion time for an activity as measured in calendar days will be reduced. However, extra wages must be paid for such overtime work, so the cost will increase. Also, overtime work is more prone to accidents and quality problems that must be corrected, so costs may increase. The activity duration can be reduced by one of the following actions:

- Applying multiple-shifts work.
- Working extended hours (over time).
- Offering incentive payments to increase the productivity.
- Working on week ends and holidays.
- Using additional resources.
- Using materials with faster installation methods.
- Using alternate construction methods or sequence.

## **8.2 Activity Time-Cost Relationship**

In general, there is a trade-off between the time and the direct cost to complete an activity; the less expensive the resources, the larger duration they take to complete an activity. Shortening the duration on an activity will normally increase its direct cost which comprises: the cost of labor, equipment, and material. It should never be assumed that the quantity of resources deployed and the task duration are inversely related. Thus one should never automatically assume that the work that can be done by one man in 16 weeks can actually be done by 16 men in one week.

A simple representation of the possible relationship between the duration of an activity and its direct costs appears in [Figure 8.1](#). Considering only this activity in isolation and without reference to the project completion deadline, a manager would choose a duration which implies minimum direct cost, called the normal duration. At the other extreme, a manager might choose to complete the activity in the minimum possible time, called crashed duration, but at a maximum cost.

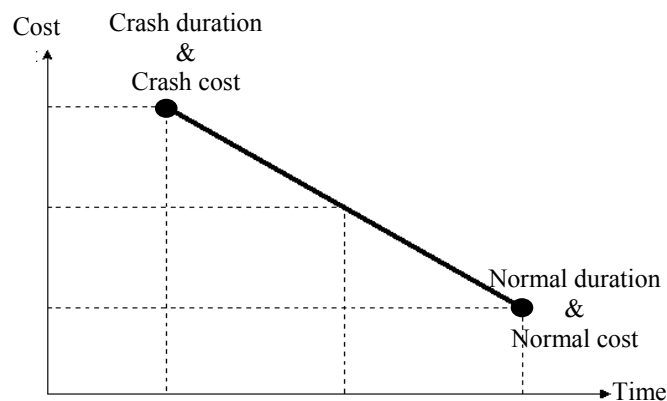

Figure 8.1: Illustration of linear time/cost trade-off for an activity

The linear relationship shown in the [Figure 8.1](#) between these two points implies that any intermediate duration could also be chosen. It is possible that some intermediate point may represent the ideal or optimal trade-off between time and cost for this activity. The slope of the line connecting the normal point (lower point) and the crash point (upper point) is called the cost slope of the activity. The slope of this line can be calculated mathematically by knowing the coordinates of the normal and crash points.

$$\text{Cost slope} = \frac{\text{crash cost} - \text{normal cost}}{\text{normal duration} - \text{crash duration}}$$

As shown in [Figures 8.1, 8.2, and 8.3](#), the least direct cost required to complete an activity is called the normal cost (minimum cost), and the corresponding duration is called the normal duration. The shortest possible duration required for completing the activity is called the crash duration, and the corresponding cost is called the crash cost. Normally, a planner start his/her estimation and scheduling process by assuming the least costly option

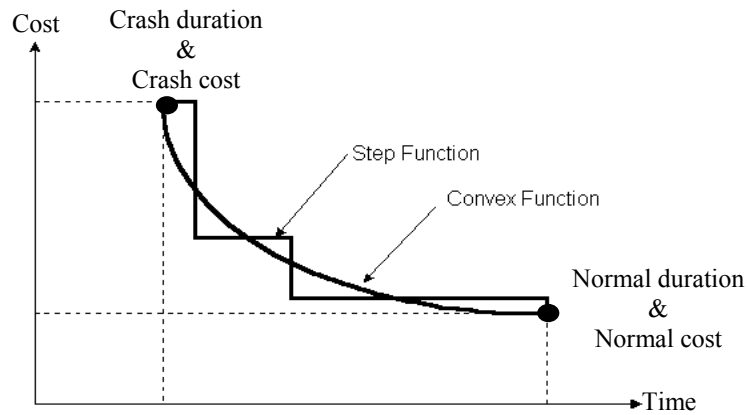

Figure 8.2: Illustration of non-linear time/cost trade-off for an activity

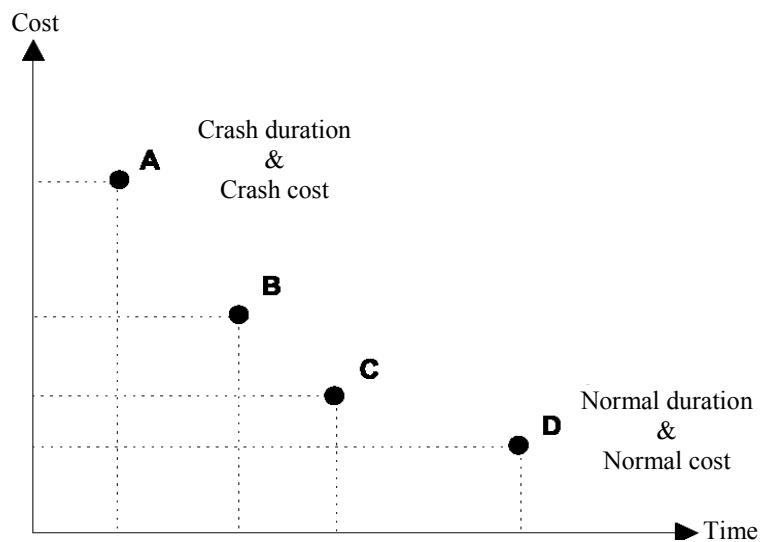

Figure 8.3: Illustration of discrete time/cost trade-off for an activity

*Example 8.1*

A subcontractor has the task of erecting 8400 square meter of metal scaffolds. The contractor can use several crews with various costs. It is expected that the production will vary with the crew size as given below:

Estimated daily production (square meter)	Crew size (men)	Crew formation
166	5	1 scaffold set, 2 labors, 2 carpenter, 1 foreman
204	6	2 scaffold set, 3 labors, 2 carpenter, 1 foreman
230	7	2 scaffold set, 3 labors, 3 carpenter, 1 foreman

Consider the following rates: Labor LE96/day; carpenter LE128/day; foreman LE144/day and scaffolding LE60/day. Determine the direct cost of this activity considering different crews formation.

*Solution*

The duration for installing the metal scaffold can be determined by dividing the total quantity by the estimated daily production. The cost can be determined by summing up the daily cost of each crew and then multiply it by the duration of using that crew. The calculations are shown in the following table.

Crew size	Duration (days)	Cost (LE)
5	50.6 (use 51)	$51 \times (1 \times 60 + 2 \times 96 + 2 \times 128 + 1 \times 144) = 33252$
6	41.2 (use 42)	$42 \times (2 \times 60 + 3 \times 96 + 2 \times 128 + 1 \times 144) = 33936$
7	36.5 (use 37)	$37 \times (2 \times 60 + 3 \times 96 + 3 \times 128 + 1 \times 144) = 34632$

This example illustrates the options which the planner develops as he/she establishes the normal duration for an activity by choosing the least cost alternative. The time-cost relationship for this example is shown in [Figure 8.4](#). The cost slop for this activity can be calculates as follow:

$$\text{Cost slope 1 (between points 1 and 2)} = (33936 - 33252) / (51 - 42) = 76.22 \text{ LE/day}$$

$$\text{Cost slope 2 (between points 2 and 3)} = (34632 - 33936) / (42 - 37) = 139.2 \text{ LE/day}$$

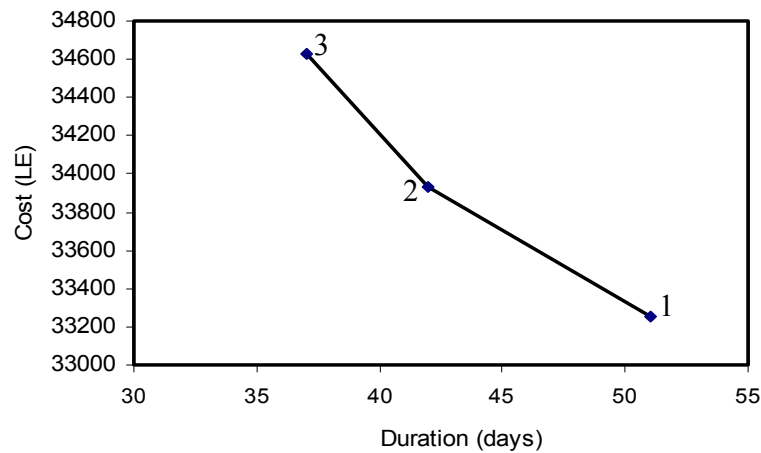

Figure 8.4: Time-cost relationship of Example 8.1

### 8.3 Project Time-Cost Relationship

Total project costs include both direct costs and indirect costs of performing the activities of the project. Direct costs for the project include the costs of materials, labor, equipment, and subcontractors. Indirect costs, on the other hand, are the necessary costs of doing work which can not be related to a particular activity, and in some cases can not be related to a specific project.

If each activity was scheduled for the duration that resulted in the minimum direct cost in this way, the time to complete the entire project might be too long and substantial penalties associated with the late project completion might be incurred. Thus, planners perform what is called time-cost trade-off analysis to shorten the project duration. This can be done by selecting some activities on the critical path to shorten their duration.

As the direct cost for the project equals the sum of the direct costs of its activities, then the project direct cost will increase by decreasing its duration. On the other hand, the indirect cost will decrease by decreasing the project duration, as the indirect cost are almost a linear function with the project duration. [Figure 8.5](#) illustrates the direct and indirect cost relationships with the project duration.

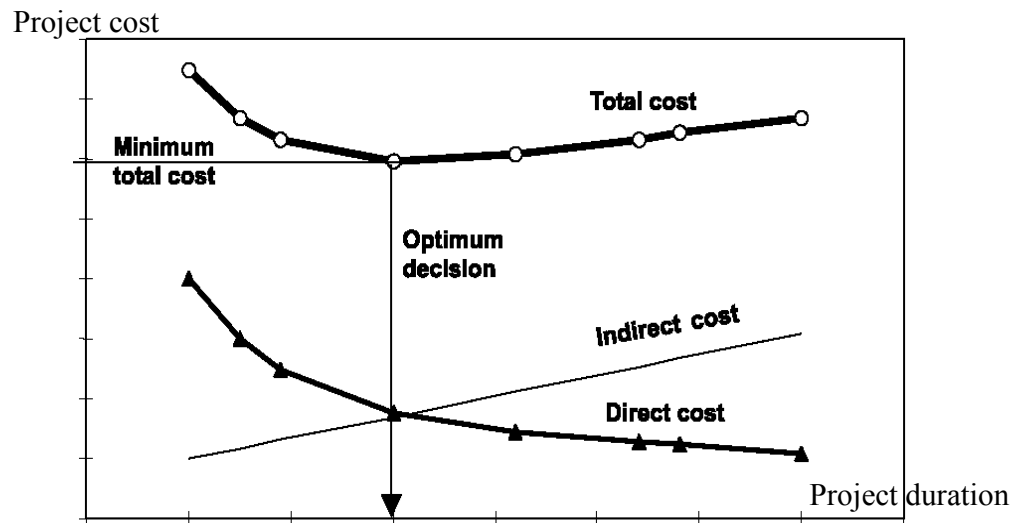

Figure 8.5: Project time-cost relationship

The project total time-cost relationship can be determined by adding up the direct cost and indirect cost values together as shown in Figure 8.5. The optimum project duration can be determined as the project duration that results in the least project total cost.

#### 8.4 Shortening Project Duration

The minimum time to complete a project is called the project-crash time. This minimum completion time can be found by applying critical path scheduling with all activity durations set to their minimum values. This minimum completion time for the project can then be used to determine the project-crash cost. Since there are some activities not on the critical path that can be assigned longer duration without delaying the project, it is advantageous to change the all-crash schedule and thereby reduce costs.

Heuristic approaches are used to solve the time/cost tradeoff problem such as the cost-lope method used in this chapter. In particular, a simple approach is to first apply critical path scheduling with all activity durations assumed to be at minimum cost. Next, the planner can examine activities on the critical path and reduce the scheduled duration of activities which have the lowest resulting increase in costs. In essence, the planner develops a list of activities on the critical path ranked with their cost slopes. The heuristic solution proceeds by shortening activities in the order of their lowest cost slopes. As the

duration of activities on the shortest path are shortened, the project duration is also reduced. Eventually, another path becomes critical, and a new list of activities on the critical path must be prepared. Using this way, good but not necessarily optimal schedules can be identified.

The procedure for shortening project duration can be summarized in the following steps:

1. Draw the project network.
2. Perform CPM calculations and identify the critical path, use normal durations and costs for all activities.
3. Compute the cost slope for each activity from the following equation:

$$\text{cost slope} = \frac{\text{crash cost} - \text{normal cost}}{\text{normal duration} - \text{crash duration}}$$

4. Start by shortening the activity duration on the critical path which has the least cost slope and not been shortened to its crash duration.
5. Reduce the duration of the critical activities with least cost slope until its crash duration is reached or until the critical path changes.
6. When multiple critical paths are involved, the activity(ies) to shorten is determined by comparing the cost slope of the activity which lies on all critical paths (if any), with the sum of cost slope for a group of activities, each one of them lies on one of the critical paths.
7. Having shortened a critical path, you should adjust activities timings, and floats.
8. The cost increase due to activity shortening is calculated as the cost slope multiplied by the time of time units shortened.
9. Continue until no further shortening is possible, and then the crash point is reached.
10. The results may be represented graphically by plotting project completion time against cumulative cost increase. This is the project direct-cost / time relationship. By adding the project indirect cost to this curve to obtain the project time / cost curve. This curve gives the optimum duration and the corresponding minimum cost.



*Example 8.2*

Assume the following project data given in Table 8.1. It is required to crash the project duration from its original duration to a final duration of 110 days. Assume daily indirect cost of LE 100.

Table 8.1: Data for Example 8.2

Activity	Preceded by	Normal		Crash	
		Duration (day)	Cost (LE)	Duration (day)	Cost (LE)
A	-	120	12000	100	14000
B	-	20	1800	15	2800
C	B	40	16000	30	22000
D	C	30	1400	20	2000
E	D, F	50	3600	40	4800
F	B	60	13500	45	18000

*Solution*

The cost slope of each activity is calculated. Both the crashability and the cost slope are shown beneath each activity in the precedence diagram. The critical path is B-C-D-E and the project duration in 140 days. Project total normal direct cost = sum of normal direct costs of all activities = LE 48300.

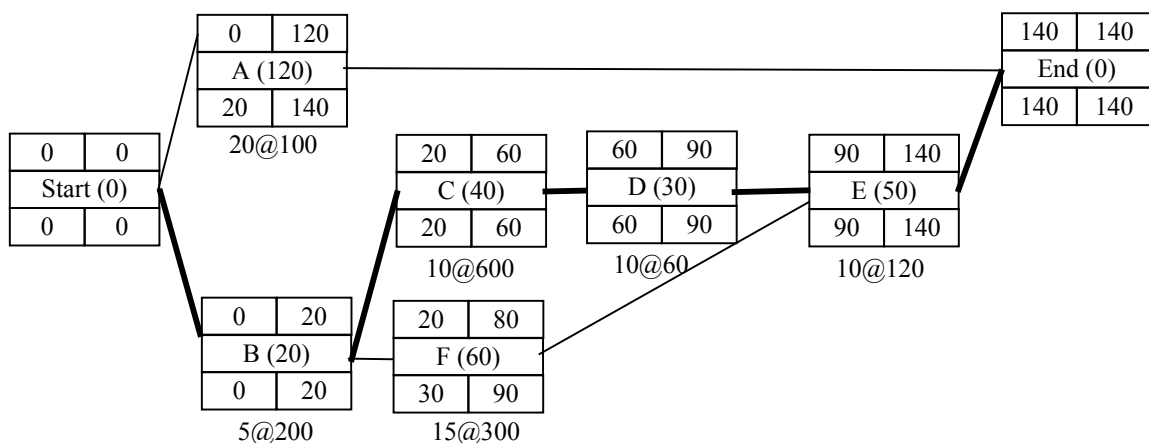

1. The activity on the critical path with the lowest cost slope is of activity “D”, this activity can be crashed by 10 days. Then adjust timing of the activities.

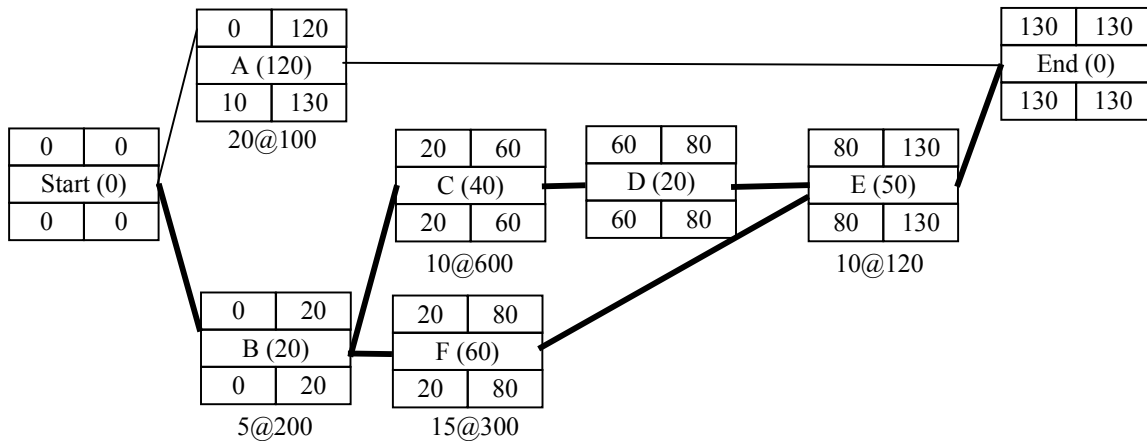

A new critical path will be formed, B-F-E.

New Project duration is 130 days.

The project direct cost is increased by  $10 \times 60 = \text{LE } 600$ .

Project direct cost =  $48300 + 600 = \text{LE } 48900$

2. At this step activity “E” will be crashed, as this activity lies on both critical paths.

Activity “E” will be shortened by 10 days.

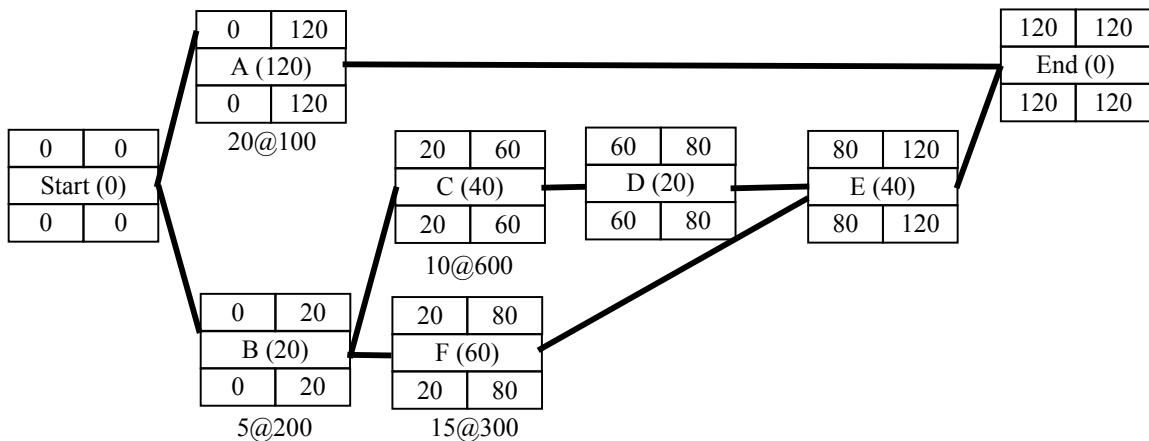

Accordingly, all activities will be turned to critical activities.

New Project duration is 120 days.

The project direct cost is increased by  $10 \times 120 = \text{LE } 1200$ .

Project direct cost =  $48900 + 1200 = \text{LE } 50100$

3. In this step, it is difficult to decrease one activity's duration and achieve decreasing in the project duration. So, either to crash an activity on all critical paths (if any), otherwise, choose several activities on different critical paths. As shown, activities "A" and "B" can be crashed together which have the least cost slope (100 + 200). Then, crash activities "A" and "B" by 5 days.

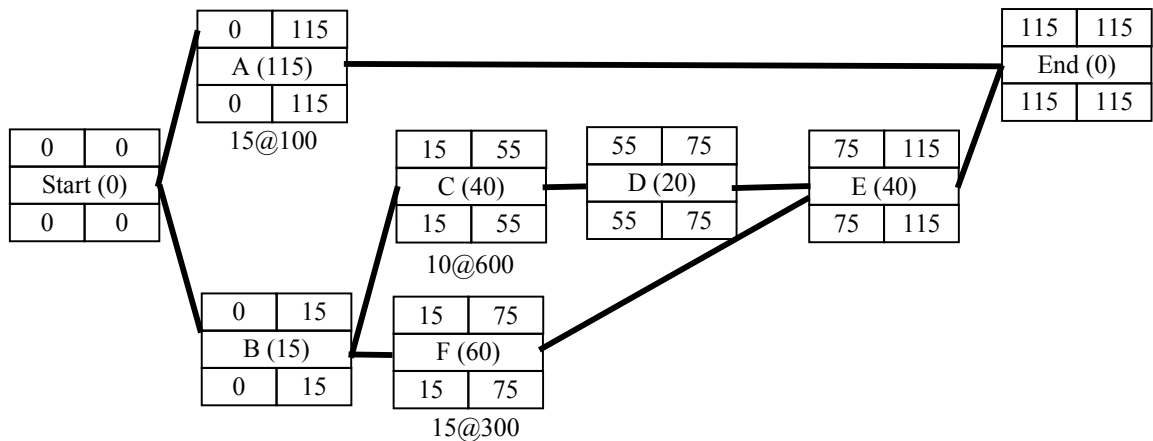

New Project duration is 115 days.

The project direct cost is increased by  $5 \times (100 + 200) = \text{LE } 1500$ .

Project direct cost =  $50100 + 1500 = \text{LE } 51600$

4. In this final step, it is required to decrease the duration of an activity from each path. The duration of activity "A" will be crashed to 110 days, "C" to 35 days, and "F" to 55 days. Thus, achieving decreasing project duration to 110 days. Also, increase in the project direct cost by  $5 \times (100 + 600 + 300) = \text{LE } 5000$

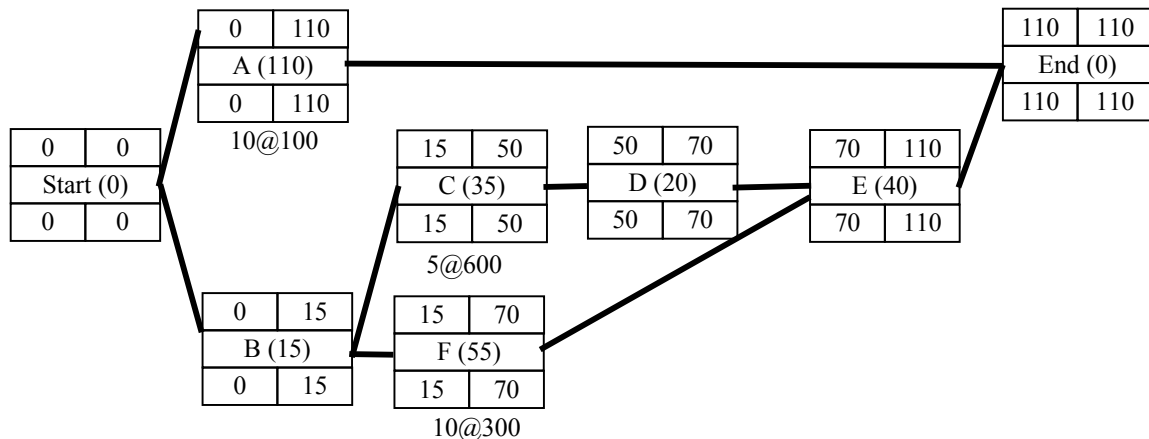

Duration (days)	Direct cost (LE)	Indirect cost (LE)	Total cost (LE)
140	48300	14000	62300
130	48900	13000	61900
120	50100	12000	62100
115	51600	11500	63100
110	56600	11000	67600

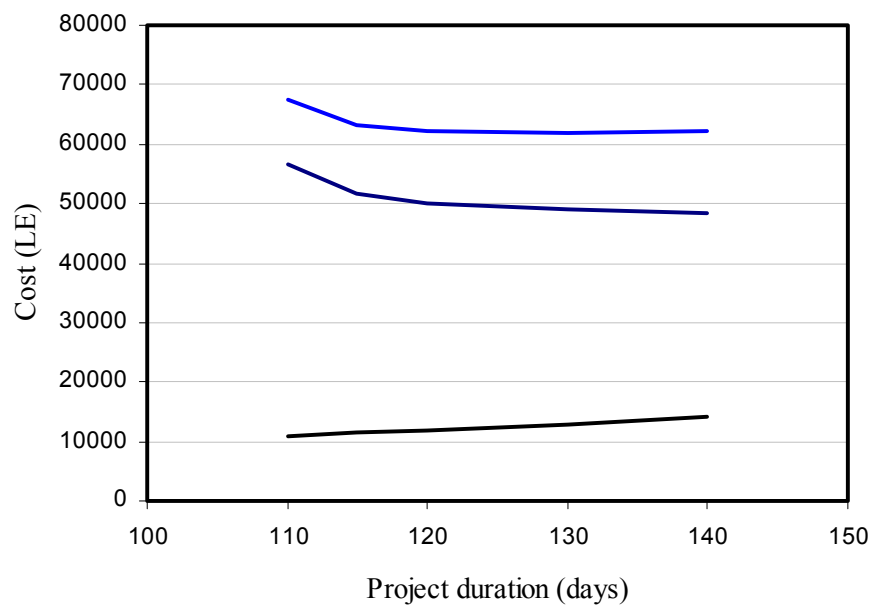

### Example 8.3

The durations and direct costs for each activity in the network of a small construction contract under both normal and crash conditions are given in the following table. Establish the least cost for expediting the contract. Determine the optimum duration of the contract assuming the indirect cost is LE 125/day.

### Solution

The cost slope of each activity is calculated. Both the crashability and the cost slope are shown beneath each activity in the precedence diagram. The critical path is A-C-G-I and the contract duration in 59 days.

Table 8.2: Data for Example 8.3

Activity	Preceded by	Normal		Crash	
		Duration (day)	Cost (LE)	Duration (day)	Cost (LE)
A	-	12	7000	10	7200
B	A	8	5000	6	5300
C	A	15	4000	12	4600
D	B	23	5000	23	5000
E	B	5	1000	4	1050
F	C	5	3000	4	3300
G	E, C	20	6000	15	6300
H	F	13	2500	11	2580
I	D, G, H	12	3000	10	3150

*Solution*

The cost slope of each activity is calculated. Both the crashability and the cost slope are shown beneath each activity in the precedence diagram. The critical path is A-C-G-I and the contract duration in 59 days.

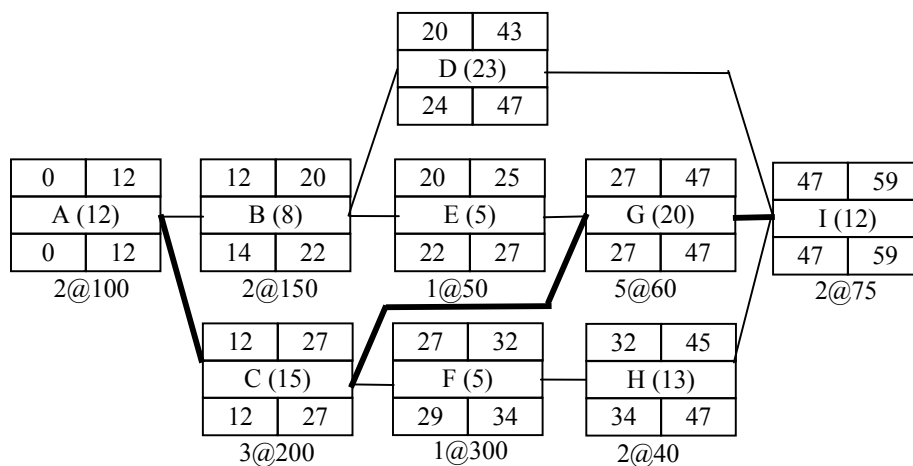

1. The activity on the critical path with the lowest cost slope is “G”, this activity can be crashed by 5 days, but if it is crashed by more than 2 days another critical path will be generated. Therefore, activity “G” will be crashed by 2 days only. Then adjust timing of the activities.

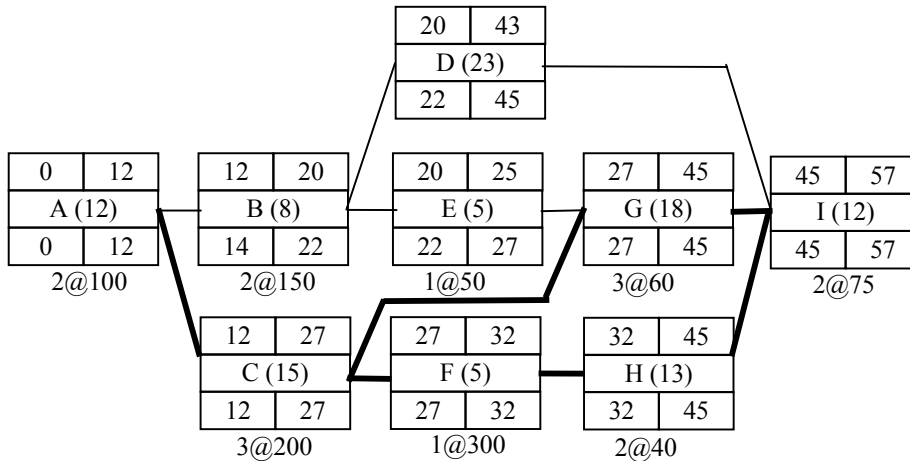

A new critical path will be formed, A-C-F-H-I.

New contract duration is 57 days and the cost increase is  $2 \times 60 = \text{LE } 120$ .

2. At this step the activities that can be crashed are listed below:

Either "A" at cost LE 100/day

Or "C" at cost LE 200/day

Or "I" at cost LE 75/day

Or "F & G" at cost LE 360/day

Or "H & G" at cost LE 100/day

Activity "I" is chosen because it has the least cost slope, and it can be crashed by 2 days. Because it is last activity in the network, it has no effect on other activities.

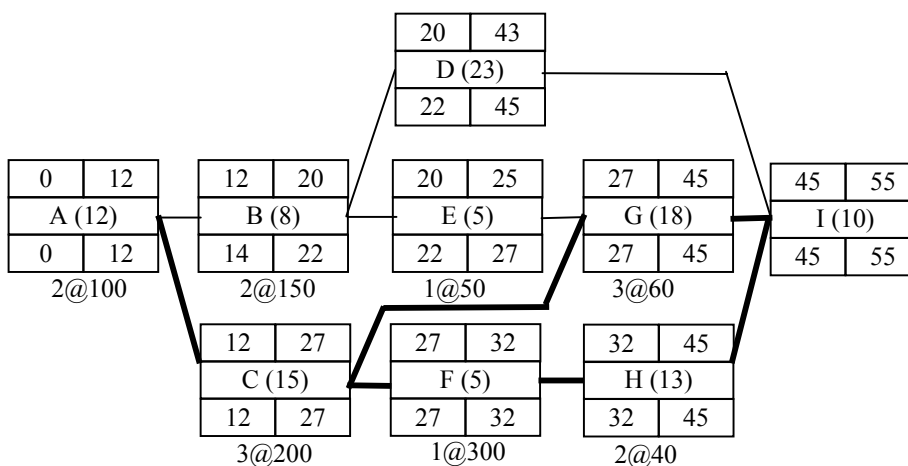

New contract duration is 55 days and the cost increase is  $2 \times 75 = \text{LE } 150$ .

Cumulative cost increase =  $120 + 150 = \text{LE } 270$

3. Now, we could select “A” or both “H & G”, because they have the same cost slope. Activity “A” is chosen to be crashed. This will change the timings for all activities, but no new critical path will be formed.

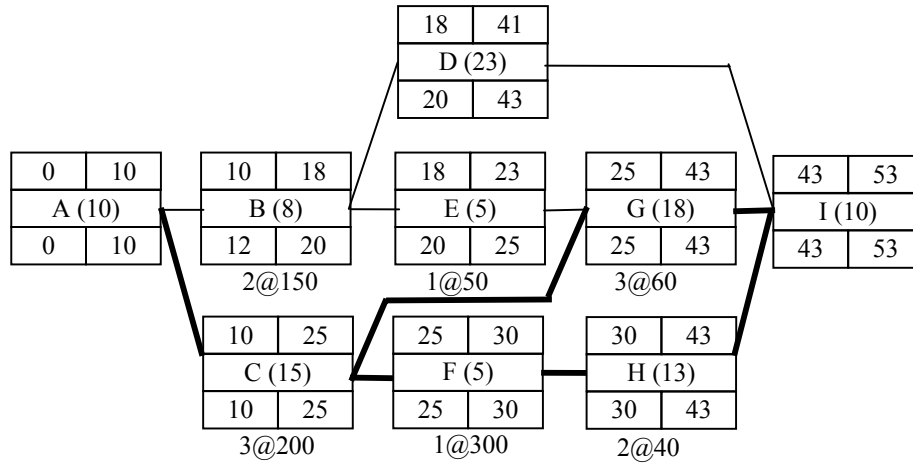

New contract duration is 53 days and the cost increase is  $2 \times 100 = \text{LE } 200$ .  
Accordingly, cumulative cost increase =  $270 + 200 = \text{LE } 470$

4. Now, activities “H & G” can be crashed by 2 days each. “A” new critical path A-B-D-I will be formed.

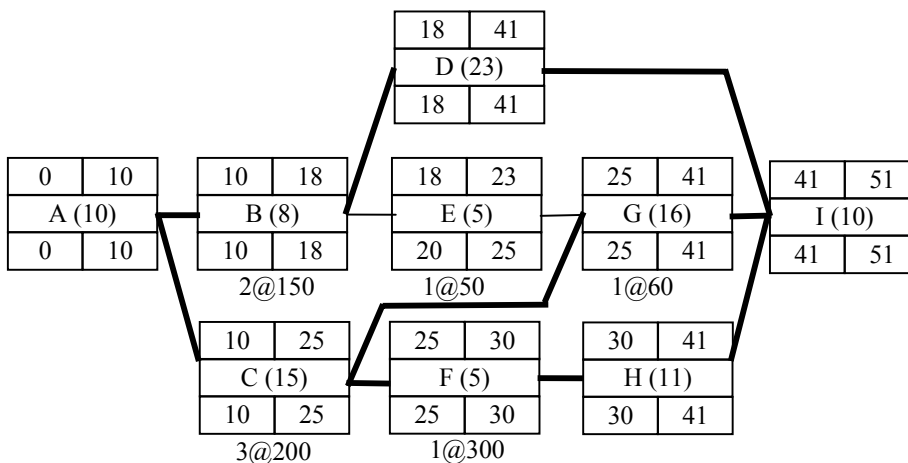

New contract duration is 51 day and the cost increase is  $2 \times 100 = \text{LE } 200$ .  
Accordingly, cumulative cost increase =  $470 + 200 = \text{LE } 670$

5. At this stage, the network has three critical paths. The activities that can be crashed are listed below:

Either C & B at cost LE 350/day or F, G & B at cost LE 510/day

Activities C & B are chosen because they have the least cost slope.

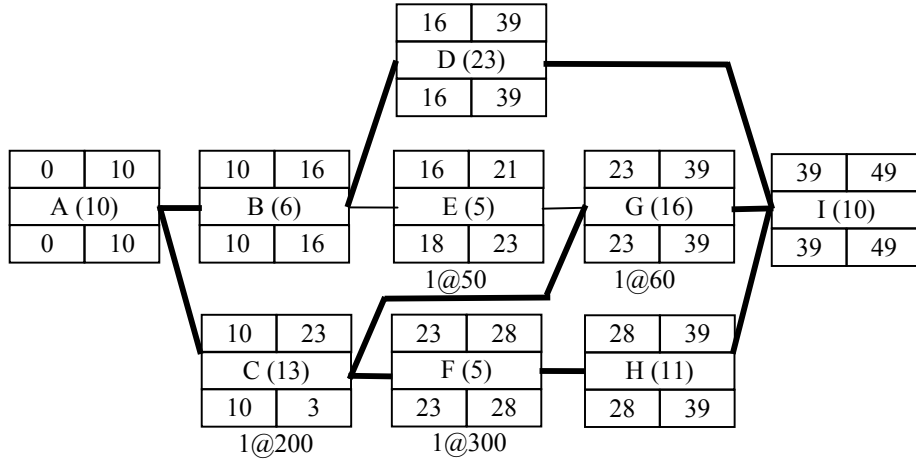

New contract duration is 49 days and the cost increase is  $2 \times 350 = \text{LE } 700$ .

Cumulative cost increase =  $670 + 700 = \text{LE } 1370$

Now, there is no further shortening is possible.

The contract duration and the corresponding cost are given in the table below.

Duration	Direct cost X 1000 LE	Indirect cost x 1000 LE	Total cost x 1000 LE
59	36.50	7.375	43.875
57	36.62	7.125	43.745
55	36.77	6.875	43.645
53	36.97	6.625	43.595
51	37.17	6.375	43.545
49	37.87	6.125	43.995

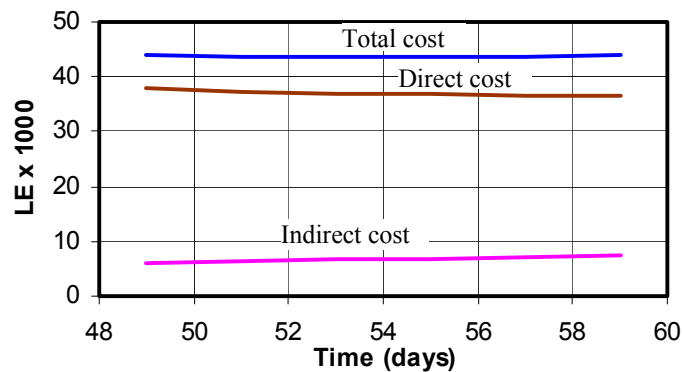



## 8.5 Exercises

1. The following table gives the activities involved in a pipeline contract. The duration and cost data are also given. The indirect cost for the contract is LE120/day. Calculate the minimum cost of the work corresponding to contract duration of 102 days.

Act.	Description	Predes.	Normal		Crashability (days)	Cost Slope (LE)
			Time	Cost		
A	Preparation	---	10	200	-	-
B	Move on to site	A	20	200	-	-
C	Obtain pipes	A	40	1800	-	-
D	Obtain valves	A	28	500	8	10
E	Locate pipeline	B	8	150	-	-
F	Cut specials	C	10	100	4	40
G	Excavate trench	E	30	3000	20	180
H	Prepare valve chambers	C, G	20	2800	12	50
I	Layout joint pipes	C, G	24	1000	10	65
J	Fit valves	D, F, H	10	200	4	80
K	Concrete anchors	I	8	520	1	80
L	Backfill	J, K	6	420	1	60
M	Finish valve chambers	J, K	6	200	3	40
N	Test pipeline	J, K	6	150	2	70
O	Clean up site	L, N	4	300	-	-
P	Leave site	M, O	2	180	-	-

2. Cost and schedule data for a small project are given below. Assume an indirect cost of LE 200/day. Develop the time-cost curve for the project and determine the minimum contract duration

Activity	Preceded by	Cost (LE)		Duration (days)	
		Crash	Normal	Crash	Normal
A	-	3900	3600	6	7
B	A	6500	5500	3	5
C	B	7200	6350	7	9
D	B	4900	4700	18	19
E	B	2200	2050	9	10
F	C	1700	1200	6	8
G	F	7200	7200	5	5
H	E	10000	9450	10	11
I	D, G, H	4700	4500	6	7

3. Draw the precedence diagram for the following data.

Activity	Followed by	Duration (days)		Cost slope LE / day
		Normal	Minimum	
A	B, E, F	7	5	200
B	K	9	5	450
C	H, D	8	7	400
D	I, N	11	4	100
E	G, M	9	6	400
F	L	8	7	500
G	C	7	5	200
H	I, N	6	2	200
I	-	12	9	200
J	E, F	10	8	600
K	G	14	10	350
L	M	18	16	700
M	C	9	8	550
N	-	12	9	200

It is required to compress the schedule to a 65-day. How much more would the project cost?